



Rizzetta & Company

Harbor Bay Community Development District

**Board of Supervisors'
Regular Meeting
April 16, 2026**

**District Office:
5020 W. Linebaugh Ave Ste 240
Tampa, Florida 33624
813.933.5571**

www.harborbaycdd.org

HARBOR BAY COMMUNITY DEVELOPMENT DISTRICT AGENDA

at the MiraBay Clubhouse Lagoon Room located at 107 Manns Harbor Drive, Apollo Beach, Florida 33572

District Board of Supervisors	Steve Finley Dean Walters Dan Leventry Micheal Rodriguez Tim Nargi	Chairman Vice Chairman Assistant Secretary Assistant Secretary Assistant Secretary
District Manager	Lynn Hayes	Rizzetta & Company, Inc.
District Attorney	Andy Cohen	Persson, Cohen, Mooney, Fernandez & Jackson, PA
District Engineer	Amy Palmer	Lighthouse Engineering

All cellular phones and pagers must be turned off during the meeting.

The Audience Comment portion of the agenda is where individuals may make comments on matters that concern the District. Individuals are limited to a total of three (3) minutes to make comments during this time.

Pursuant to provisions of the Americans with Disabilities Act, any person requiring special accommodations to participate in this meeting/hearing/workshop is asked to advise the District Office at least forty-eight (48) hours before the meeting/hearing/workshop by contacting the District Manager at 813-933-5571. If you are hearing or speech impaired, please contact the Florida Relay Service by dialing 7-1-1, or 1-800-955-8771 (TTY) 1-800-955-8770 (Voice), who can aid you in contacting the District Office.

A person who decides to appeal any decision made at the meeting/hearing/workshop with respect to any matter considered at the meeting/hearing/workshop is advised that person will need a record of the proceedings and that accordingly, the person may need to ensure that a verbatim record of the proceedings is made including the testimony and evidence upon which the appeal is to be based.

HARBOR BAY COMMUNITY DEVELOPMENT DISTRICT

District Office – Wesley Chapel, Florida (813) 994-1001
Mailing Address – 3434 Colwell Avenue Suite 200, Tampa, Florida 33614
www.harborbaycdd.org

April 13, 2026

Zoom Link: <https://zoom.us/j/91993427543>

Meeting ID: 919 9342 7543

Passcode: 129708

Phone: 929-205-6099

Board of Supervisors
**Harbor Bay Community
Development District**

REVISED AGENDA

Dear Board Members:

The regular meeting of the Board of Supervisors of the Harbor Bay Community Development District will be held on **Thursday, April 16, 2026 at 6:00 p.m.**, at the MiraBay Clubhouse Lagoon Room located at 107 Manns Harbor Drive Apollo Beach, FL, 33572. The following is the revised agenda for this meeting:

BOS MEETING

- 1. CALL TO ORDER/ROLL CALL**
- 2. PLEDGE OF ALLEGIANCE**
- 3. AUDIENCE COMMENTS ON AGENDA ITEMS**
- 4. BUSINESS ITEMS**
 - A. Discussion of RFP for District Management Services
 - B. Discussion of Wild Animal Trapping
 - C. Consideration of Sidewalk Grinding Proposals..... Tab 1
 - D. Discussion of Hurricane Pre/Post Storm
- 5. STAFF REPORTS**
 - A. Aquatic Report
 - i. Blue Water Fountain Report Tab 2
 - ii. Blue Water Aquatic Report Tab 3
 - iii. Consideration of Fountain Proposals..... Tab 4
 - B. Presentation of LT Kim Landscape Reports Tab 5
 - i. 8.2 Acre Parcel Entitlement Update
 - C. District Counsel
 - i. Discussion of Encroachments in CDD ROW

- D. District Engineer
 - i. Consideration of Bathymetric Study Proposals (under separate cover)
 - ii. Discussion of Roadway Analysis Tab 6
 - iii. Consideration of Dock & Lift Applications Tab 7
 - iv. Marisol Pointe Erosion Update Tab 8
- E. District Coordinator
 - i. Presentation of District Coordinator Report Tab 9
 - ii. Presentation of Project/Reserve/Contract/Tracker.. Tab 10
- F. District Manager
 - i. Presentation of District Manager Report..... Tab 11
- G. Onsite Manager Reports
 - i. Director of Operations Report Tab 12
 - ii. Consideration of Pirate Bay Athletics Proposal..... Tab 13
 - iii. Field Operations Manager Report..... Tab 14
- 6. **CONSENT AGENDA/BUSINESS ADMINISTRATION**
 - A. Consideration of Minutes of the Board of Supervisors' Regular Meeting Minutes of March 19, 2026..... Tab 15
 - B. Ratification of Operation & Maintenance Expenditures For February 2026..... Tab 16
 - C. Presentation of February 2026 Financial Statement..... Tab 17
- 7. **AUDIENCE COMMENTS ON NON-AGENDA ITEMS**
- 8. **SUPERVISOR REQUESTS**
- 9. **ADJOURNMENT**

We look forward to seeing you at the meeting. In the meantime, if you have any questions, please do not hesitate to call us at (813) 994-1001.

Sincerely,

Lynn Hayes

Lynn Hayes
District Manager

Tab 1



April 7, 2026

Proposal #19823426

Contact

Clay Wright
Phone: 727 408-2094
cwright@rizetta.com

Customer

Rizzetta
107 Manns Harbor Drive
Apollo Beach FL 33572

Job

Harbor Bay CDD
107 Manns Harbor Drive
Apollo Beach FL 33572

PARKING LOT IMPROVEMENTS

Concrete Sidewalk and Grinding

Scope of work:

1. Secure job site for safety of crew and public with barricades and/or cones.
2. Grind concrete sidewalk in 156 areas totaling approximately 764 linear feet.
3. Demo concrete sidewalk in 15 areas totaling approximately 885 square feet (Concrete saws must be used in conjunction with water to avoid dust accumulating).
4. Haul debris from site.
5. Set forms and pour 15 new sections of 4" concrete sidewalk totaling approximately 885 square feet using 3,000 PSI concrete reinforced with commercial fiber mesh.
6. Apply a broom finish and apply control joints as required.
7. Cleanup the job site.

Labor and Material - \$40,412.00

PARKING LOT IMPROVEMENTS

Notes:

*DUE TO THE CRITICAL NATURE OF ESCALATING MATERIAL COSTS, MATERIAL PRICES ARE SUBJECT TO POTENTIAL MONTHLY, WEEKLY OR DAILY CHANGES. SHOULD THIS SITUATION ARISE, ACPLM WILL PROVIDE DOCUMENTATION OF MATERIAL ADJUSTMENT(S). A BILLABLE CHANGE ORDER MAY BE REQUIRED DUE TO THESE CHANGES.

*PRICE IS GOOD ONLY IF ACPLM HAS FULL AND UNRESTRICTED ACCESS TO THE WORK AREA TO INCLUDE A STAGING AREA FOR THE DURATION OF THE PROJECT. NOT HAVING FULL AND UNRESTRICTED ACCESS TO THE WORK AREA TO INCLUDE A STAGING AREA FOR THE DURATION OF THE PROJECT CAN RESULT IN ADDITIONAL WORK AND/OR MOBILIZATIONS WHICH SHALL BE AN EXTRA COST TO BE PAID BY THE CUSTOMER.



Office: 813.633.0548
Fax: 813.634.2686



www.acplm.net



2010 S 51st Street,
Tampa, FL 33619



April 7, 2026

Proposal #19823426

Contact

Clay Wright
Phone: 727 408-2094
cwright@rizetta.com

Customer

Rizetta
107 Manns Harbor Drive
Apollo Beach FL 33572

Job

Harbor Bay CDD
107 Manns Harbor Drive
Apollo Beach FL 33572

PARKING LOT IMPROVEMENTS

Notes:

- *WORK TO BE DONE IN ONE MOBILIZATION, WHICH COVERS THE DURATION AND COMPLETION OF THE PROJECT. IF ADDITIONAL MOBILIZATIONS ARE REQUESTED BY THE CUSTOMER THE ADDITIONAL MOBILIZATIONS WILL BE AN EXTRA CHARGE.
- *WORK TO BE DONE ON WEEKDAYS IN DAYLIGHT HOURS.
- *NO WORK WILL BE PERFORMED IN THE DEPARTMENT OF TRANSPORTATION RIGHT OF WAY.
- *PROPOSAL DOES NOT INCLUDE THERMOPLASTIC PAINT, TESTING, FLAGMEN, LANE CLOSURE, IMPACT FEES, SURVEYING, AS-BUILTS, EROSION CONTROL, SHOP DRAWINGS AND ENGINEERING. ANY ADDITIONAL WORK REQUIRED BY ANY ADDITIONAL ITEMS, WILL BE AN EXTRA COST TO BE PAID BY THE CUSTOMER.
- *ACPLM IS NOT RESPONSIBLE FOR DAMAGE TO UNDERGROUND UTILITIES TO INCLUDE PUBLIC UTILITIES AND PRIVATE UTILITIES SUCH AS, BUT NOT LIMITED TO, IRRIGATION, PHONE AND CABLE LINES. ANY ADDITIONAL WORK REQUIRED BY ANY ADDITIONAL OF THESE TYPES OF ITEMS, WILL BE AN EXTRA COST TO BE PAID BY THE CUSTOMER.
- *NOT INCLUDED IN THIS PROPOSAL ARE PLANT OPENING FEES FOR WEEKEND WORK. IF NECESSARY, THIS ADDITIONAL ITEM WILL BE AN EXTRA COST TO BE PAID BY THE CUSTOMER.
- *PROPOSAL DOES NOT INCLUDE IRRIGATION LINES, SPRINKLER HEADS, SOD, NOR LANDSCAPING. EVERY EFFORT WILL BE MADE NOT DAMAGE THESE ITEMS. HOWEVER, DUE TO THE NATURE OF THIS TYPE OF WORK AND THE DAMAGE ALREADY CAUSED BY THE ROOTS, SOME DAMAGE MAY OCCUR IN ORDER TO MAKE THE NECESSARY REPAIRS. ANY ADDITIONAL WORK REQUIRED BY ANY ADDITIONAL ITEMS, WILL BE AN EXTRA COST TO BE PAID BY THE CUSTOMER. IF WORK IS APPROVED, IT IS RECOMMENDED THE LANDSCAPING COMPANY IS MADE AWARE AND ON STAND BY.
- *NOT INCLUDED IN THE ABOVE SCOPE OF WORK IS ANY SELECT FILL MATERIAL.
- *DUE TO THE NATURE AND SCOPE OF THIS WORK, THE LOCATION OF THIS WORK, THE MATERIAL, TRUCKING AND EQUIPMENT NECESSARY TO PERFORM THIS WORK, ACPLM MAY CAUSE SCUFFING AND ADVERSELY AFFECT THE AESTHETICS OF THE PAVEMENT IN AND AROUND THE WORK AREAS. ALTHOUGH EVERY EFFORT WILL BE MADE TO MINIMIZE ANY AND ALL AFFECTS, ACPLM CANNOT GUARANTEE AGAINST THEM. ADDITIONAL WORK REQUIRED BY ANY OF THESE TYPE OF ITEMS WILL BE AN EXTRA COST TO BE PAID BY THE CUSTOMER.



Office: 813.633.0548
Fax: 813.634.2686



www.acplm.net



2010 S 51st Street,
Tampa, FL 33619



April 7, 2026

Proposal #19823426

Contact

Clay Wright
Phone: 727 408-2094
cwright@rizetta.com

Customer

Rizetta
107 Manns Harbor Drive
Apollo Beach FL 33572

Job

Harbor Bay CDD
107 Manns Harbor Drive
Apollo Beach FL 33572

PARKING LOT IMPROVEMENTS

Notes continued:

- *DUE TO THE SURROUNDING ELEVATIONS IN THE WORK AREA, IT CANNOT BE GUARANTEED THAT STANDING WATER WILL BE 100% ELIMINATED. THIS WORK WILL NOT CORRECT ANY EXISTING DRAINAGE PROBLEMS ON SITE. SLOPES WITH LESS THAN ¼ OF AN INCH OF FALL PER FOOT ARE CONSIDERED FLAT AND ACPLM WILL NOT BE RESPONSIBLE FOR PONDING OF WATER.
- *IF PROBLEMS WITH THE SUBBASE ARE DISCOVERED DURING REPAIR AND INSTALLATION OPERATIONS, E.G. CONTAMINATED SUBBASE, SATURATED SUBBASE FROM UNDERGROUND WATER, AND/OR CLAY IN THE SUBGRADE, ETC., IT WILL BE BROUGHT TO MANAGEMENT’S ATTENTION FOR A CHANGE ORDER BEFORE WORK PROCEEDS.
- *ACPLM CAN NOT GUARANTEE AGAINST THE FUTURE REGROWTH OF ROOTS AFTER REPAIRS ARE COMPLETE.
- *IN ORDER TO ENSURE PROPER CURE TIME AND AVOID IMPRESSIONS IN THE NEWLY POURED CONCRETE RESULTING FROM PEDESTRIAN, BIKE, SHOPPING CART, VENDOR, ETC. TRAFFIC, NEWLY POURED AREAS OF CONCRETE WILL BE CORDONED OFF FOR A MINIMUM OF 24 HOURS. IF ACPLM IS NOT PERMITTED TO CORDON OFF NEWLY POURED CONCRETE AREAS, ACPLM IS NOT RESPONSIBLE FOR ANY IMPRESSIONS IN THE NEW CONCRETE AND A CHANGE ORDER WILL BE REQUIRED TO FIX DAMAGED AREAS.
- *CONCRETE WORK DOES NOT INCLUDE THE FOLLOWING: ZIP STRIP, REBAR, STRUCTURAL FOOTERS, COLUMNS OR RETAINING WALLS. ANY ADDITIONAL WORK REQUIRED BY ANY ADDITIONAL OF THESE TYPE OF ITEMS, WILL BE AN EXTRA COST TO BE PAID BY THE CUSTOMER.
- *CONCRETE THICKER THAN THE PROPOSED THICKNESS WILL BE BROUGHT TO MANAGEMENT'S ATTENTION FOR A CHANGE ORDER TO COMPENSATE FOR THE EXTRA LABOR, TRUCKING AND MATERIAL REQUIRED TO COMPLETE THE WORK.
- *BECAUSE OF THE POTENTIAL FOR FLEXING OF THE SUB BASE IN THE FLORIDA REGION, NEW CONCRETE MAY EXPERIENCE PREMATURE CRACKING AT ANY POINT AFTER CURING BEYOND OUR CONTROL. PREMATURE CRACKING IS NOT REFLECTIVE OF POOR QUALITY OF MATERIAL OR INFERIOR WORKMANSHIP.
- *THIS CONTRACTOR IS NOT RESPONSIBLE FOR ANY PERSONS WHO WRITES OR DRAWS IN THE NEW CONCRETE DURING THE CONCRETES CURING TIME. A CHANGE ORDER WILL BE REQUIRED TO FIX DAMAGED AREAS CAUSED BY VANDALISM.



Office: 813.633.0548
Fax: 813.634.2686



www.acplm.net



2010 S 51st Street,
Tampa, FL 33619



April 7, 2026

Proposal #19823426

Contact

Clay Wright
Phone: 727 408-2094
cwright@rizetta.com

Customer

Rizetta
107 Manns Harbor Drive
Apollo Beach FL 33572

Job

Harbor Bay CDD
107 Manns Harbor Drive
Apollo Beach FL 33572

PARKING LOT IMPROVEMENTS

Notes continued:

- *CONCRETE SAW CUTTING WILL CAUSE DUST TO ACCUMULATE IN THE AIR AND WIND MAY CAUSE THE DUST TO SETTLE ON NEARBY PARKED CARS AND BUILDING STRUCTURE.
- *ADDITIONAL CONCRETE USED FOR LEVELING LOW AREAS IS NOT INCLUDED INTO THE PROPOSAL AMOUNT. OVERAGES ON CONCRETE DUE TO LEVELING OF LOW AREAS WILL BE BILLED TO CUSTOMER AND PAID FOR AT THE UNIT PRICE OF \$145.00 PER LEVELING CUBIC YARD.
- *IT IS THE CUSTOMER'S RESPONSIBILITY TO HAVE A TOWING COMPANY ON SITE AND AVAILABLE FOR TOWING VEHICLES OBSTRUCTING THE JOB SITE. IF VEHICLES CANNOT BE MOVED IN A TIMELY MANNER, WE WILL NEED TO RESCHEDULE THE WORK AND A CHANGE ORDER WILL BE REQUIRED FOR THE ADDITIONAL MOBILIZATION.
- *BARRICADES WILL BE PROVIDED TO CLOSE OFF WORK AREAS. THIS CONTRACTOR IS NOT RESPONSIBLE FOR PERSONS ENTERING AREAS CLOSED OFF WITH BARRICADES, DAMAGE TO PROPERTY OR INJURY TO PERSONS ENTERING THE AREA.
- *PERMIT FEES AND PROCUREMENT FEES ARE NOT INCLUDED. ANY ADDITIONAL WORK, TESTING OR INSPECTIONS REQUIRED BY THE PERMIT, WILL BE AN EXTRA COST THAT SHALL BE PAID BY THE CUSTOMER.
- *90% OF THE CONTRACT AMOUNT AND CHANGE ORDERS MUST BE PAID PRIOR TO COMPLETING PUNCH LIST ITEMS AND/OR CHANGES FOR ADDITIONAL WORK REQUIRED BY CITIES OR MUNICIPALITIES.
- *MATERIAL AND WORKMANSHIP ARE GUARANTEED FOR 12 MONTHS.



Office: 813.633.0548
Fax: 813.634.2686



www.acplm.net



2010 S 51st Street,
Tampa, FL 33619



April 7, 2026

Proposal #19823426

Contact

Clay Wright
Phone: 727 408-2094
cwright@rizetta.com

Customer

Rizzetta
107 Manns Harbor Drive
Apollo Beach FL 33572

Job

Harbor Bay CDD
107 Manns Harbor Drive
Apollo Beach FL 33572

PARKING LOT IMPROVEMENTS

Customer Billing Information

Thank you for choosing ACPLM. To ensure we contact the correct person for any billing correspondence and questions, please fill out the Billing Contact Information below and send back with your signed proposal. We look forward to working with you.

The terms of your contract are:

Net Upon Substantial Completion

If Paying by ACH Payment the ACH Fees Will Be Added to the Invoiced Amount Due

Acceptance of Terms – Payment will be made as outlined above. All payments later than 30 days after the due date shall bear interest at 18% per annum.

Bill To Name and Address:

Job Site Name and Address:

Billing Contact Name:

Billing Phone Number:

Email Address:

Billing Instructions:



Office: 813.633.0548
Fax: 813.634.2686



www.acplm.net



2010 S 51st Street,
Tampa, FL 33619



April 7, 2026

Proposal #19823426

Contact

Clay Wright
Phone: 727 408-2094
cwright@rizetta.com

Customer

Rizzetta
107 Manns Harbor Drive
Apollo Beach FL 33572

Job

Harbor Bay CDD
107 Manns Harbor Drive
Apollo Beach FL 33572

PARKING LOT IMPROVEMENTS

Terms: Net Upon Substantial Completion

If Paying by ACH Payment the ACH Fees Will Be Added to the Invoiced Amount Due

ACPLM Authorized Signature _____ *Rudy White*

Rudy White

Cell: 813- 992- 6440 rwhite@acplm.net

Acceptance of Proposal – The above prices, specifications and conditions are satisfactory and are hereby accepted. You are authorized to do the work as specified. Payment will be made as outlined above. All payments later than 30 days after the due date shall bear interest at 18% per annum.

Date of Acceptance _____

Customer’s Authorized Signature _____

Terms and Conditions: Payment is due in full upon project completion unless prior arrangements have been made in advance. If any legal action arises out of this agreement or breach thereof, the customer will be responsible for all attorney fees and incurred late fees. Any alteration of deviation from the above specifications involving extra costs of material or labor will be an additional charge outside of the scope listed in this proposal. Sprinkler systems on the property are to be off for the duration of the project. Customer assumes responsibility for removing all vehicles from the area outlined above.

All material is guaranteed to be as specified. All work to be completed in a workmanlike manner according to standards practices. Any alteration or authorized deviation from the original specifications, involving extra cost, to be executed only upon receiving written change orders and will become an extra charge over and above this estimate. All agreements contingent upon strikes, accidents, weather or delay beyond our control. Owner to carry fire, tornado and other necessary insurance. Our employees are fully covered by Workers Compensation Insurance. Due to the unpredictable movement of material and production costs, this proposal is good for 10 days from proposal date, after which prices are subject to change to accommodate current industry pricing.

Proposal Amount - \$40,412.00



Office: 813.633.0548
Fax: 813.634.2686



www.acplm.net



2010 S 51st Street,
Tampa, FL 33619

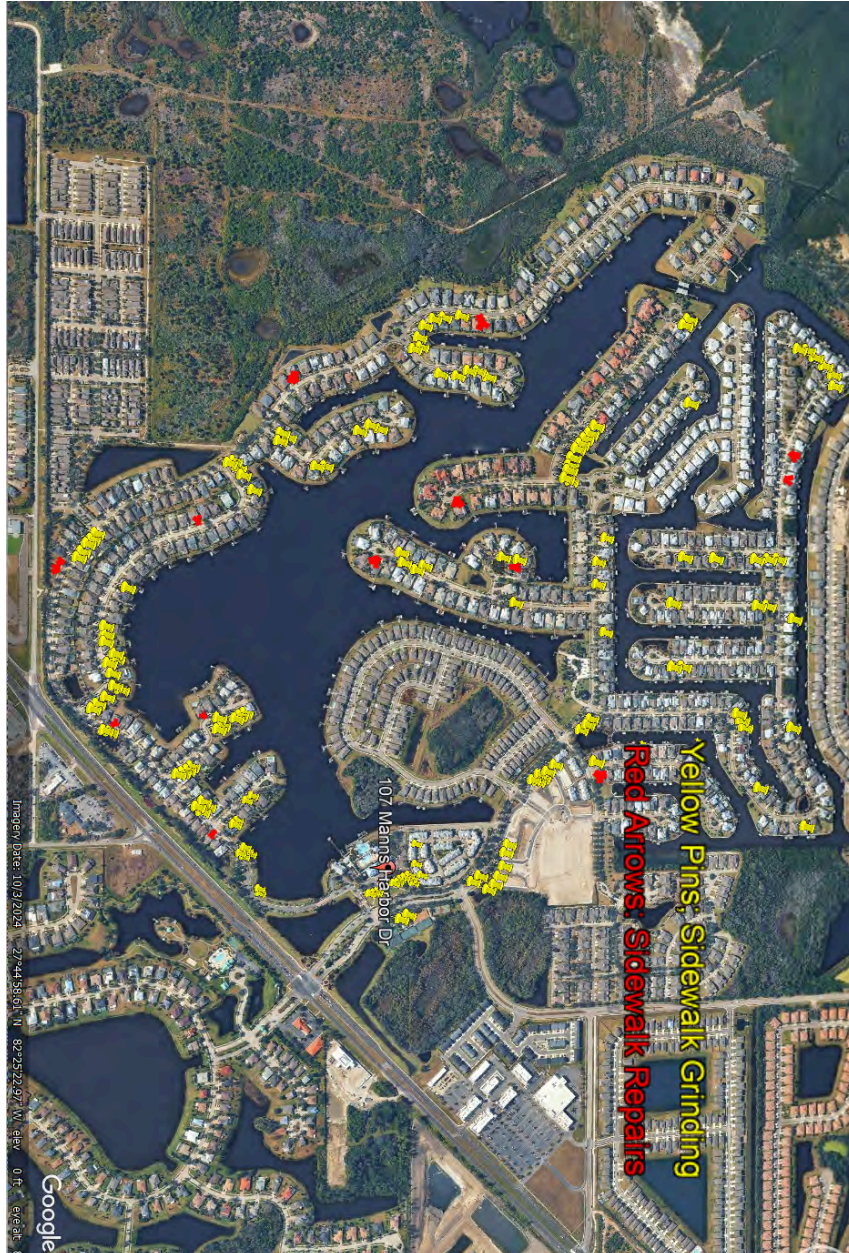

Sidewalk repairs: 5x15,5x17,5x10,5x15,5x15,5x15,5x8,5x18,5x12,5x17,5x5,5x5,5x5,9x5,5x11= 885 Square Feet

Sidewalk Grinding:

764 linear Feet of sidewalk grinding.



Office: 813.633.0548
Fax: 813.634.2686



www.acplm.net



2010 S 51st Street,
Tampa, FL 33619

PROPOSAL

Steve Simmons Concrete, Inc.

2728 39th Ave. SE • Ruskin, FL 33570 • 813-313-8383
 Licensed • Insured • simmonsconcreteinc.com
 Solid Foundations, Lasting Quality



Date: April 6, 2026

Proposal submitted to: MiraBay - Harbor Bay

Work to be performed at: _____

Phone: _____ Email: _____

We hereby propose to furnish the materials and perform the labor necessary for the completion of:

HP = High Priority • LP = Low Priority

AREA	HP GRIND	LP GRIND	RIP OUT & REPLACE
Right side Mirabay Blvd. from guard shack to Wishing Arch	12	8	10 panels
Right side Mirabay Blvd from Wishing Arch to Ibisview	11		
Right side Mirabay Blvd. from Ibisview to Islebay	5	3	3 panels at Islebay & Mirabay
Right side Mirabay Blvd from Islebay to round-about	7	16	
Right side from round-about to end of Blvd.	5	15	2 panels #628
Left side Mirabay Blvd. from back to round-about	4	5	
Balibay	18	17	7 panels #604 pondside 3 panels #607 pondside
Tybee Island	5	25	
Left side Mirabay Blvd. from round-about to Meritt Island	6	11	
Mirabay Blvd. from Meritt Island to guard shack	27	18	
Merritt Island	11	22	
Beacon Sound	6	5	2 panels #505
Right side Islebay to Grand Isle sign	11	30	
Grand Isle sign to Marsh Isle sign	6	12	1 panel #611
Marsh Isle to #829	4	8	
Left side #831 to #720	4	1	
Interior Islebay cul-de-sac	9	12	
Left side Islebay #720 to Sea Trout	1	2	
Left side Islebay from Sea Trout to Tortoise		1	
Tortoise	4	8	
Left Isle Bay Tortoise to Sea Turtle		2	
Left side Islebay Sea Turtle to Blvd.	10	20	
Back side Windrose to Summerside		3	
Back side Windrose Summerside to end	1	4	
Inside Windrose (corner Golden to end)	4	4	1 panel @ 208
Right side Golden from Lattitude to Golden	2	4	
Right side Golden from Lattitude to gate	4	12	
Right side Golden Sela to Sela Cove	3	2	
Right side Golden Sela to Breakers	3	2	4 panels
Right side Golden Breakers to Oceania		4	
Right side Golden Oceania to Windrose	3		
Cafrey Place Blvd. to gate	2	3	

Continued on next page

PROPOSAL

Steve Simmons Concrete, Inc.

2728 39th Ave. SE • Ruskin, FL 33570 • 813-313-8383
 Licensed • Insured • simmonsconcreteinc.com
 Solid Foundations, Lasting Quality



Date: April 6, 2026

Proposal submitted to: MiraBay - Harbor Bay

Work to be performed at: _____

Phone: _____ Email: _____

We hereby propose to furnish the materials and perform the labor necessary for the completion of:

HP = High Priority • LP = Low Priority

AREA	HP GRIND	LP GRIND	RIP OUT & REPLACE
Back side at gate to clubhouse	1		
At handicap spot 123 Aberdeen Pond	1		
Golden Isles from left Seacrest Column to Oceania	4	6	1 panel #5607
Left side Golden Isle from Oceania to Breakers		4	
Left side Golden Isle from Breakers to Breakers	3	8	1 panel across from #5320 GI 6 panels at #235
Left side Golden Isle from Breakers to #5210	1	4	3 panels across from #5212
Corner of Sela Cove Circle and Golden Isles	1		
Back side Golden Isles from Sela to Breakers		4	
Back side Golden Isles from Breakers to Oceania		4	
Left side Ibisview to Skimmer		3	3 panels, remove first tree
Wishing Arch		7	
Left side of Skimmer Drive to #5640	2	8	
Right side of Skimmer Drive to #5640	7	11	3 panels #5603
Left side Ibis from Skimmer to Seagrass	2	4	3 panels, second tree
Seagrass Place	2	7	2 panels #5613
Left side of Ibis from Seagrass to Seacrest sign	2	10	2 panels, first tree 1 panel, first tree 2 panels between first & second tree 1 panel, third tree
Right side Ibis from Seacrest sign to Seagrass		7	3 panels, first oak tree
Right side from Seagrass to Blvd.	4	6	
Left side Manns Harbor from Point Harbor to guard gate		5	2 panels
Right side Manns Harbor from Brighton to Loon Nest	4	2	
Loon Nest	11	22	
Right side Manns Harbor Loon Nest to Fisher Sound	3	9	3 panels, #631
Fisher Sound	4	8	2 panels, #5311 3 panels, #5311 1 panel, #5321
Right side Manns from Fisher Sound to water plant pavers in road	2	1	
Left side from water plant to Anglers Cove sign	3	8	
Left side Manns Harbor from Anglers Cove to playground	3	16	1 panel
Brighton Shore	17	25	3 panels, #5248

Continued on next page

PROPOSAL

Steve Simmons Concrete, Inc.
 2728 39th Ave. SE • Ruskin, FL 33570 • 813-313-8383
 Licensed • Insured • simmonsconcreteinc.com
 Solid Foundations, Lasting Quality



Date: April 6, 2026

Proposal submitted to: MiraBay - Harbor Bay

Work to be performed at: _____

Phone: _____ Email: _____

Continued from previous page

AREA	HP GRIND	LP GRIND	RIP OUT & REPLACE
Right side Manns Harbor from guard gate to Cove Sound	4	3	
Cove Sound Way	7	12	3 panels, #5211
Right side Manns Harbor from Cove Sound to Point Harbor	4	1	
Point Harbor Lane	8	19	4 panels, #5214 (2 in driveway) 1 panel, #5202
Right side Manns Harbor from Point Harbor to Brighton Shore	2	4	
Right side Manns Harbor from Brighton Shore to Brighton Shore	8	18	2 panels, #543
Left side Manns Harbor from Wolf Creek Park to Winterside	6	8	2 panels across street, #557
Left side Manns Harbor from Winterside to Brighton Shore	1	7	2 panels, #532
			3 panels across form #525
			2 panels across from #523
			2 panels across from #521
Left side Manns Harbor from Brighton Shore to Point Harbor	2	6	2 panels across from #433 2 panels, #422
High Priority	310	\$75	\$23,250
Low Priority	546	\$40	\$21,840
Rip Out & Replace*	104	\$450	\$46,800
TOTAL			\$91,890

**NOTE: Rip out and replacements include cutting of tree roots from area and sprinkler repair when needed.*

*Cracks in concrete are inevitable. There are many factors contributing to this including shrinkage and weather. We will do everything possible to minimize the appearance of cracks by pre-cutting control joints. **We DO NOT guarantee this will prevent cracking.***

PROPOSAL includes all materials as specified, and the above work performed in accordance with the drawings/specifications submitted and completed in a substantial workmanlike manner.

ACCEPTANCE: The above prices, specifications and conditions are satisfactory and are hereby accepted. Steve Simmons Concrete Inc. is authorized to complete this contract as specified. Payment will be made as outlined.

Date: _____ Signature: _____



3527 Golden Eagle Drive
Land O' Lakes, Florida 34639
813-973-7256 / 813-431-7256
www.SuperiorSidewalkServices.com

SURVEY ESTIMATE AND PRICE PROPOSAL

Harbor Bay
Apollo Beach, Florida 33572

March 16, 2026

Removal of the trip hazards within Harbor Bay was reviewed again at the request of Clayton Wright, District coordinator with Rizzetta & Company. Potential trip hazards are typically classified and grouped into the categories shown below:

CATEGORY	HAZARD HEIGHT
Least Severe (LS)	¼ inch to ½ inch
Severe (S)	½ inch to 1 inch
Most Severe (MS)	1 inch to 2 inches
Replace	Greater than 2 inches

FILL TYPE	HAZARD WIDTH
Crack	¼ inch
Gap	½ inch
Cement	

For each category of a trip hazard, an estimated quantity of concrete that needs to be removed is developed as part of the cost estimate. Maximum concrete removal is included in the estimate.

The concrete surfaces along the sidewalk that require remediation are hazards with heights between ¼ inches and 2 inches. To avoid trip and fall injuries and meet ADA requirements, grinding down the concrete is recommended to eliminate these locations. The proposed locations are summarized in the following table.

Trip Hazards in Concrete Surfaces				
	Least Severe	Severe	Most Severe	Fill
Main Entrance	10	9	3	Cement – 3 Crack – 2
Tennis Court Area	20	13	5	-
Clubhouse	30	25	4	Cement – 4 Crack – 4
Security Gate	5	4	1	-
Boulevard	19	6	2	Crack
Skimmer Drive				
5602	1	0	0	-
5603	6	2	0	-
5607	2	0	0	-
5609	1	0	1	-
5610	1	0	0	-
5611	1	0	0	-
5613	1	1	0	-
5615	1	1	0	-
5616	0	1	0	-
5617	1	0	0	-
5620	1	0	0	Cement – 2
5621	1	0	0	-
5630	1	1	0	Cement
5632	0	1	1	-
5634	1	0	0	-
5636	3	0	0	-
5638	1	1	0	-
5640	2	0	0	-
Seagrass Place				
5602	4	2	2	-
5603	1	1	4	-
5606	3	0	0	-

5607	1	0	0	-
5610	3	0	0	-
5613	1	0	1	-
5618	0	1	0	-
Ibis View Dog Park	4	2	1	Crack
Mirabay Boulevard				
From Gate to Park	52	25	3	-
429	3	0	0	-
437	0	1	0	-
439	0	0	1	-
501	2	0	0	-
503	0	0	1	-
504	0	0	1	-
505	1	0	0	-
508	0	1	1	-
510	0	0	1	-
512	0	1	0	-
514	0	1	0	-
Tybee Island Drive				
609	2	1	1	-
610	0	0	1	-
612	1	0	1	-
616	1	1	0	-
617	0	1	0	-
618	1	0	1	-
619	0	1	2	-
623	0	0	1	-
627	2	0	0	-
628	0	1	3	-
629	1	0	0	-
5402	0	1	0	-

5405	0	2	0	-
5407	0	0	1	-
5408	1	0	0	-
5414	0	1	3	-
5416	1	0	0	-
5503	1	0	0	-
5505	2	0	0	-
Balibay Road				
607	1	2	1	-
610	0	1	0	-
615	1	4	0	-
617	1	0	0	-
618	0	1	0	-
619	0	0	1	-
623	0	1	1	-
625	0	1	0	-
628	1	1	1	-
631	0	0	1	-
Balibay Pond	6	10	20	Cement
Merritt Island Drive				
5403	0	0	1	-
5405	0	0	2	-
5407	0	1	0	-
5409	1	1	1	-
5410	0	1	0	-
5412	0	1	0	-
5415	0	0	1	-
5416	1	1	1	-
5417	0	0	1	-
5419	0	1	0	-
5421	0	1	0	-

5505	0	2	0	-
5506	0	1	4	-
5508	1	0	0	-
5514	2	0	0	-
5517 to Park	1	3	0	-
Beacon Sound Way				
501	0	0	2	-
505	0	2	1	-
507	0	0	1	-
508	2	0	0	-
509	1	1	0	-
Covesound Way				
5203	1	1	1	-
5205	0	2	0	-
5206	0	1	1	-
5207	0	1	2	-
5211	2	2	2	-
5214	1	0	0	-
5216	1	0	0	-
Manns Harbor Drive				
308	1	0	0	-
310	0	0	1	-
312	1	1	1	-
402	2	0	0	-
404	1	0	2	-
406	2	1	0	-
407	1	1	0	-
409	0	1	1	-
410	1	0	0	-
411	1	2	0	-
412	1	2	0	-

414	0	1	1	-
416	5	0	0	-
418	1	1	1	-
420	0	5	2	-
422	0	1	1	-
423	1	1	0	-
424	0	1	1	-
426	0	2	1	-
427	1	0	0	-
431	0	0	1	-
433	0	0	3	-
435	0	2	2	-
Grass Field	1	3	4	-
505	1	1	0	-
507	1	1	0	-
509	1	1	0	-
511	0	2	0	-
521	1	2	0	-
527	0	0	1	-
529	2	1	0	-
530	3	1	0	-
532	1	0	2	-
539	3	0	0	-
542	0	2	0	-
543	0	1	3	-
545	0	1	2	-
549	0	0	1	-
552	0	1	0	-
553	1	0	0	-
554	0	0	1	-
555	0	1	0	-

559	0	1	0	-
561	1	0	0	-
563	0	0	1	-
603	1	0	0	-
505	1	0	1	-
607	0	2	2	-
609	0	2	3	-
614	0	0	2	-
615	0	1	1	-
622	1	0	0	-
623	0	1	1	-
626	0	2	1	-
628	2	0	0	-
630	0	0	1	-
631	0	1	1	-
635	0	1	0	-
637	0	2	0	-
706 Pond	3	0	0	-
718	0	1	0	-
719	0	1	0	-
720	2	0	0	-
731	0	1	0	-
Park	4	1	5	-
Pond	3	2	4	-
Point Harbor Lane				
5205	0	1	1	-
5206	0	1	0	-
5208	0	0	1	-
5210	0	0	0	Cement – 2
5211	0	0	1	-
5215	0	1	0	-

5216	0	1	2	-
5217	0	1	0	-
5220	0	2	0	-
5222	0	0	2	-
Brighton Shore Drive				
5205	1	0	1	-
5211	0	0	0	Cement
5212	0	1	0	-
5214	1	1	0	-
5218	1	0	1	-
5220	0	1	0	-
5222	0	0	3	-
5224	2	1	0	-
5226	1	0	0	-
5232	2	1	2	-
5235	1	1	0	-
5236	0	1	2	-
5238	3	1	0	-
5244	2	0	0	-
5245	1	0	1	-
5246	1	2	0	-
5247	0	2	1	-
5248	0	0	3	-
5250	1	3	0	-
5251	0	2	0	-
5252	0	1	0	-
5257	0	0	1	-
5261	0	0	1	-
Pond	0	0	2	-
Loon Nest Court				
5305	0	0	1	-

5306	0	1	0	-
5311	0	2	0	-
5314	0	0	1	-
5315	0	0	1	-
5318	2	0	2	-
5319	0	2	1	-
5320	2	1	0	-
5321	0	1	1	-
5325	1	1	0	-
5327	0	1	1	-
Fishersound Lane				
5309	0	0	1	-
5311	0	2	1	-
5321	0	0	1	-
Sea Crest Entrance	3	2	0	-
Golden Isles Drive				
207	7	3	0	-
208	9	5	1	Gap
5212	1	0	0	-
5310	0	1	0	-
5312	2	0	0	-
5314	0	1	0	-
5316	0	1	1	-
5318	2	0	1	-
5320	0	1	0	-
5324	2	0	0	-
5507	1	0	0	-
5509	6	5	1	-
5511	0	1	0	-
5604	0	0	1	Gap
5608	1	0	0	-

5615	0	1	1	-
Park	6	2	2	-
Sela Cove Circle				
207	3	3	2	-
Breakers Lane				
212	3	0	0	-
213	2	2	1	-
235	3	4	2	-
236	6	6	1	-
TOTAL				
	352	286	198	

Proposal Includes:

- Trip hazard removal using Airtec ES-2000 and RT-2500 Scarifiers hooked to a vacuum to remediate dust.
- A hand grinder or smoothing drum hooked to a vacuum will provide a smooth and even finish to the concrete surface.
- The use of a generator for a power source.
- Proposed work will be completed on dates agreed to by the requestor and Superior Sidewalk Services.
- Completion of the project is contingent upon potential weather delays.
- Superior Sidewalk Services shall be notified of any concerns relating to work completed within 48 hours for resolution.
- Price proposal is valid for 90 days. After that time, verification of trip hazards and adjustment of cost due to quantity or severity of hazards may be required.

Total Price of the Entire Proposal is \$ 109,975.00.

Deposit Required for Mobilization is \$ 34,000.00.

Total price of the Severe and Most Severe only is \$ 79,690.00.

Deposit Required for Mobilization is \$ 25,000.00

Total price of the Most Severe only is \$ 47,560.00.

Deposit Required for Mobilization is \$ 16,000.00

Acceptance of Proposal: The above cost and specifications are satisfactory and are hereby accepted.

Printed Name and Title

Signature

Date

Thank You For Your Business!



“We Eliminate Trip Hazards
to Avoid Law Suits”



Tab 2

Aquatic Services Report

Technician

Randy Mitchell

Job Details

Service Date	3/12/2026
Customer	Harbor Bay CDD
Weather Conditions	Partly Cloudy
Wind	N 5mph
Temperature	75
Multiple Sites Treated	Yes

Ponds Treated Information

Repeatable - 1 Count

1 of 1

Pond Numbers	North and South Fountains
Service Performed	Cleaning & Inspection (Fountain/Aeration)
Water Level	Normal
Observations/Recommendations	Cleaned floats, lights, nozzles, and intake screens on both fountains.

Pictures





Aquatic Services Report

Aquatic Services Report

Technician

Pete Dennis

Job Details

Service Date	3/26/2026
Customer	Harbor Bay CDD
Weather Conditions	Sunny
Wind	6mph
Temperature	70°
Multiple Sites Treated	No
Pond Number	North fountain
Service Performed	Cleaning & Inspection (Fountains/Aeration)
Work Performed	<input checked="" type="checkbox"/> Fountain / Aeration
Equipment Used	<input checked="" type="checkbox"/> Other
Water Level	Low
Restrictions	None
Observations/Recommendations	I cleaned the fountain, nozzle, and intake.
Pictures	

Aquatic Services Report





Order report

Service details	
Technician: Randy Mitchell	Client: Harbor Bay CDD
Service Date	1/28/2026
Request Warranted	Yes
Action Taken	Removed pump and dropped it off at Site one.
Service Date	1/28/2026
Customer	Harbor Bay CDD
Weather Conditions	Sunny
Wind	N 5mph
Temperature	48
Multiple Sites Treated	No
Pond Number	North Fountain
Service Performed	Troubleshooting
Work Performed	<input checked="" type="checkbox"/> Fountains / Aeration
Equipment Used	<input checked="" type="checkbox"/> Bass Boat
Water Level	Normal
Restrictions	None
Observations/Recommendations	Pump dropped off at Site one
Pictures:	

Order report





Order report

Service details

Technician:
Randy Mitchell

Client:
Harbor Bay CDD

Service Date	3/5/2026
Request Warranted	Yes
Action Taken	We bypassed the breaker and soft start to test motor. We found the motor running high amps. We pulled fountain in and found the banjo clamp rusted and fell apart. This allowed the oil to leak causing the motor to run hot causing the high amps. While inspecting motor We found the welds that hold the bracket that holds motor to fountain have failed. We pulled the motor to bring back to shop.
Service Date	3/5/2026
Customer	Harbor Bay CDD
Weather Conditions	Sunny
Wind	N 5mph
Temperature	80
Multiple Sites Treated	No
Pond Number	South Fountain
Service Performed	Troubleshooting
Work Performed	<input checked="" type="checkbox"/> Fountains / Aeration
Equipment Used	<input checked="" type="checkbox"/> Bass Boat
Water Level	Low
Restrictions	None
Observations/Recommendations	Recommend new fountain

Pictures:

Order report

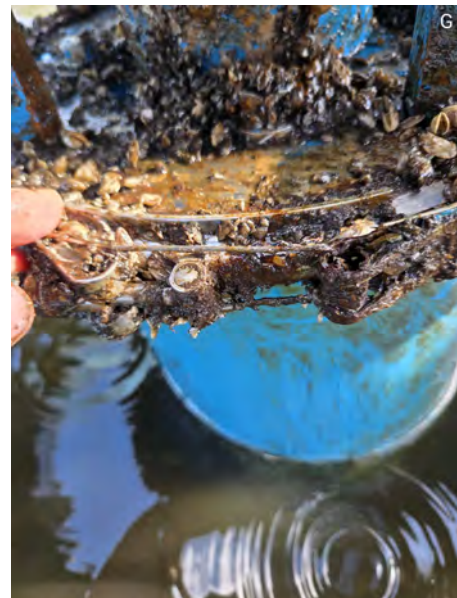
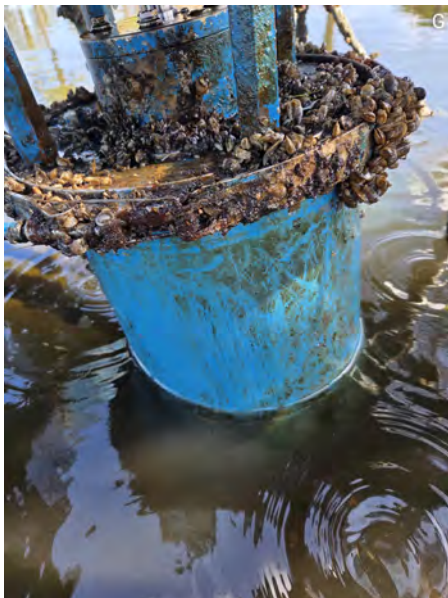

Order report

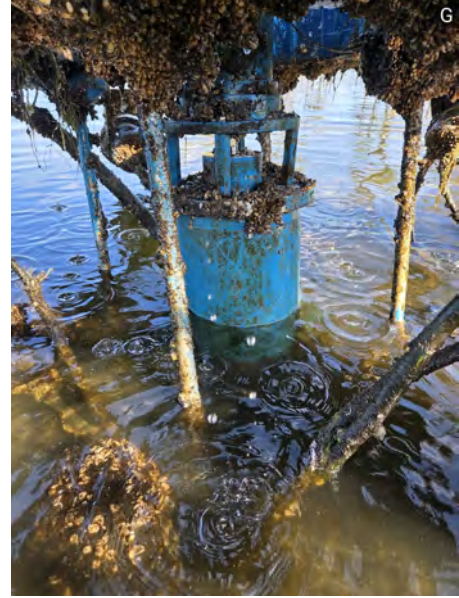



Order report

Service details	
Technician:	Client:
Randy Mitchell	Harbor Bay CDD
Service Date	3/12/2026
Request Warranted	Yes
Action Taken	Installed new warranty motor. Fountain back to normal operation.
Service Date	3/12/2026
Customer	Harbor Bay CDD
Weather Conditions	Partly Cloudy
Wind	N 5mph
Temperature	75
Multiple Sites Treated	No
Pond Number	North Fountain
Service Performed	Repairs
Work Performed	<input checked="" type="checkbox"/> Fountains / Aeration
Equipment Used	<input checked="" type="checkbox"/> Bass Boat
Water Level	Normal
Restrictions	Nonr
Observations/Recommendations	Fountain back up and running properly.
Pictures:	

Order report

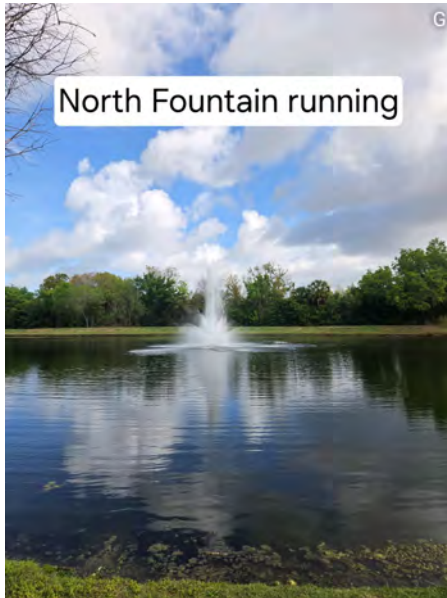

Tab 3

Chris Thompson

Blue Water Aquatics, Inc.

Mar 22, 2026 | 19 Photos



Harbor Bay CDD



March

So far this month, we've seen drier-than-normal conditions across the area, which has kept water levels low throughout the property. Temperatures have been fairly mild overall, with cooler mornings in the 60s and daytime highs reaching into the low 80s. These warmer days are starting to wake things up around the ponds, including early plant growth and some light algae activity. With the water levels down, nutrients are more concentrated, which can make it easier for algae to get established. We're starting to see that in some areas, and it's something we're keeping a close eye on. The shallow conditions have also made the ponds more active with wildlife, especially birds and amphibians taking advantage of the easier access to the water. Across the property, low water levels continue to expose shoreline areas and limit how water moves through the ponds. As we head into the next part of the season, we're preparing for the expected increase in rainfall. When the rains return and water levels rise, we typically see a flush of nutrients entering the ponds, which can lead to more noticeable algae growth. We'll continue to monitor conditions closely and adjust as needed as we move into the wetter part of the season.



South Fountain -

- 10/03/2024 – South fountain motor replacement approved
- 11/24/2024 – South fountain motor installed (316 stainless steel brackish-water rated)
- 04/24/2025 – South fountain not running. The unit was pulled and the motor housing was found filled with water due to metal erosion and barnacle damage to the housing. The replacement motor was covered under warranty by Aquamaster.
- 06/12/2025 – Warranty replacement motor installed

Project: The Mirabay Club
Date: Mar 5, 2026, 1:33 PM
Creator: Chris Thompson

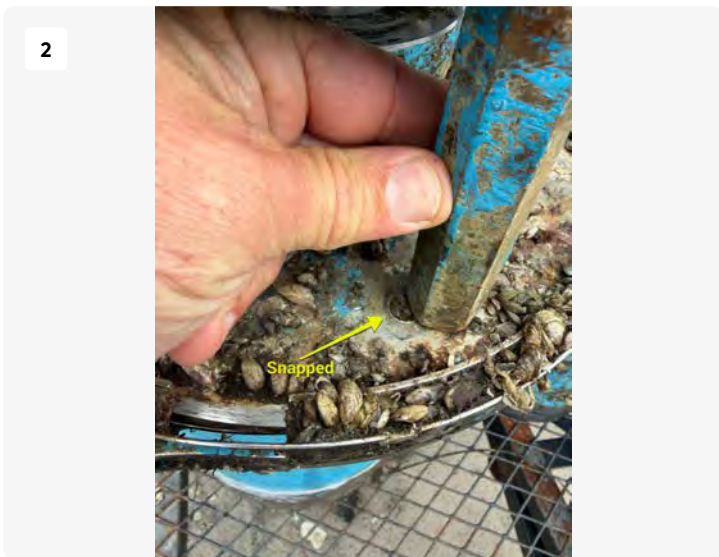

Threaded rod snapped.

Project: The Mirabay Club
Date: Mar 5, 2026, 1:33 PM
Creator: Chris Thompson

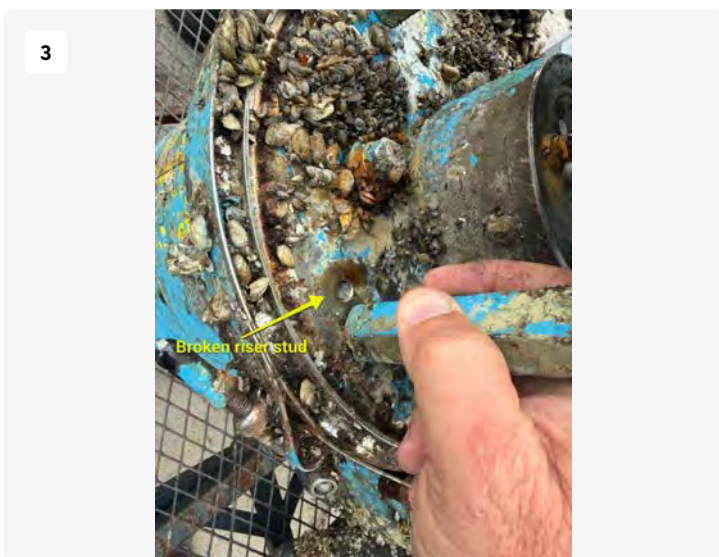

Threaded rod snapped,

Project: The Mirabay Club
Date: Mar 5, 2026, 1:34 PM
Creator: Chris Thompson

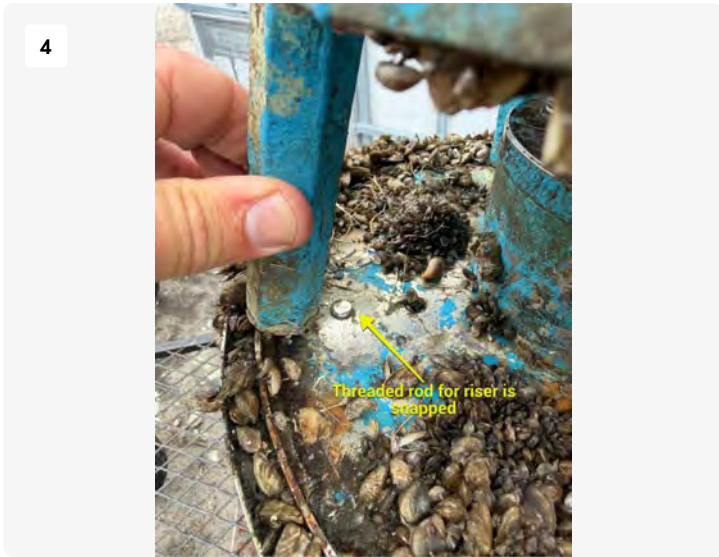

Threaded rod snapped,

Project: The Mirabay Club
Date: Mar 5, 2026, 1:33 PM
Creator: Chris Thompson

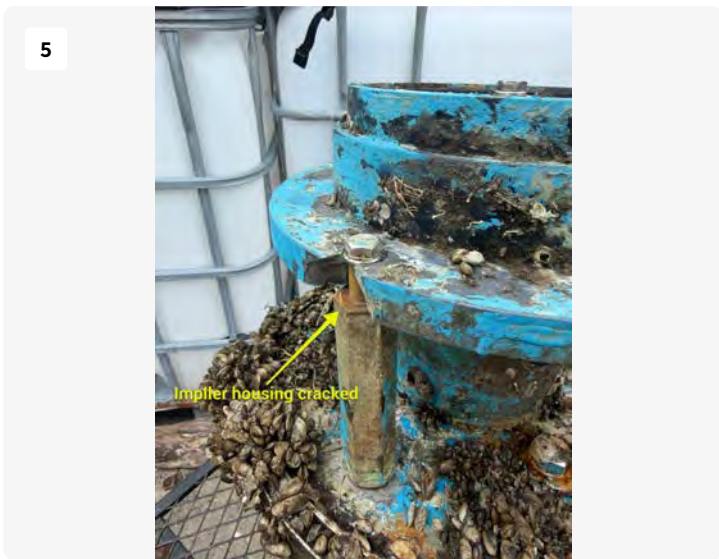

Impellor housing cracked.

Project: The Mirabay Club
Date: Mar 5, 2026, 1:33 PM
Creator: Chris Thompson

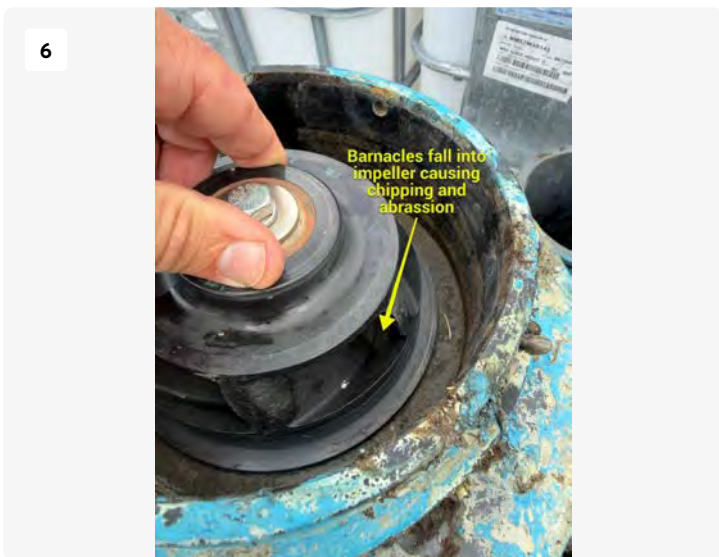

Barnacles fall into impellor causing the chips in the impellor.

Project: The Mirabay Club
Date: Mar 5, 2026, 1:34 PM
Creator: Chris Thompson



Impellor bearing is binding.

Project: The Mirabay Club
Date: Mar 5, 2026, 1:34 PM
Creator: Chris Thompson



316 stainless steel components not being used by manufacturer.

Project: The Mirabay Club
Date: Mar 5, 2026, 1:34 PM
Creator: Chris Thompson



Block wall along Cafrey Place

Vegetation was treated with a long acting systemic herbicide. Allow 3-4 weeks for signs of control.

Project: The Mirabay Club
Date: Mar 20, 2026, 3:35 PM
Creator: Chris Thompson



Pond 8 (Shell Cove) - Looking south

We have reduced most of the Hydrilla growing in the pond. We added Sonar Infinity to help finish off the Hydrilla and provide control throughout the spring and summer. Learn more about Hydrilla [here](#)

Project: The Mirabay Club
Date: Mar 20, 2026, 3:58 PM
Creator: Chris Thompson



Pond 8

Beneficial bacteria treatments have helped increase water clarity and reduce algae growth.

Project: The Mirabay Club
Date: Mar 20, 2026, 3:58 PM
Creator: Chris Thompson



Pond 8 - Looking west

Shallow conditions are promoting early submersed vegetation growth. Management focused on limiting establishment.

Project: The Mirabay Club
Date: Mar 20, 2026, 3:58 PM
Creator: Chris Thompson



Pond 8 - EROSION - Behind 228 Breakers Lane

Recommend consulting engineer to determine source.

Project: The Mirabay Club
Date: Mar 20, 2026, 3:59 PM
Creator: Chris Thompson



Pond 8 Littoral Shelf

The shelf is still bone dry. The transplants are doing fairly well considering the conditions. We will need lots of rain to get this shelf back to it's normal condition.

Project: The Mirabay Club
Date: Mar 20, 2026, 4:00 PM
Creator: Chris Thompson



Pond 8 Littoral Shelf

Conditions are very dry, but with rain we expect to see good regrowth. This shelf is vital to filtering excess nutrients from pond 8 before exiting the weir into the canal/bay.

Project: The Mirabay Club
Date: Mar 20, 2026, 4:00 PM
Creator: Chris Thompson



Spider Lillies

Project: The Mirabay Club
Date: Mar 20, 2026, 4:01 PM
Creator: Chris Thompson



Native Iris

Project: The Mirabay Club
Date: Mar 20, 2026, 4:01 PM
Creator: Chris Thompson



Blue Iris Flowering

Project: The Mirabay Club
Date: Mar 20, 2026, 4:01 PM
Creator: Chris Thompson



Giant Bullrush

The winter frost was very rough for these. There are signs of new growth.

Project: The Mirabay Club
Date: Mar 20, 2026, 4:02 PM
Creator: Chris Thompson

Order report

Service details	
Technician: Chris Thompson	Client: Harbor Bay CDD
Service Date	3/20/2026
Action Taken	Completed
Pictures	



Service Date	3/20/2026
Customer	Harbor Bay CDD
Weather Conditions	Sunny
Wind	SW@5
Temperature	89
Multiple Sites Treated	No
Pond Number	Block wall along Cafrey Pl.
Service Performed	Treatment
Work Performed	<input checked="" type="checkbox"/> Other

Order report

Equipment Used

Backpack

Other

Water Level

Medium

Restrictions

None

Observations/Recommendations

Sprayed with Imazapyr to long term control.
Allow 3-4 weeks for signs of action. Full
control can take 30-45 days.

Aquatic Services Report

Technician

Randy Mitchell

Job Details

Service Date	3/12/2026
Customer	Harbor Bay CDD
Weather Conditions	Partly Cloudy
Wind	ESE 8mph
Temperature	79
Multiple Sites Treated	Yes



Ponds Treated Information

Repeatable - 2 Count

1 of 2

Pond Numbers	All
Service Performed	Treatment
Work Performed	<input checked="" type="checkbox"/> Grasses
Equipment Used	<input checked="" type="checkbox"/> ATV/UTV
Water Level	Low
Restrictions	None
Observations/Recommendations	Treated sites for invasive vegetation (torpedo grass, pennywort, alligatorweed, cattails) as needed.

Pictures

Aquatic Services Report



Aquatic Services Report



Aquatic Services Report

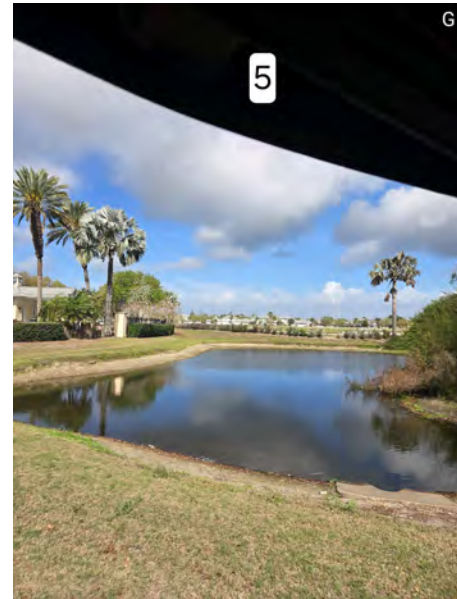

2 of 2

Pond Numbers

8

Service Performed

Treatment

Work Performed

Algae

Equipment Used

ATV/UTV

Water Level

Extremely Low

Restrictions

3 days

Observations/Recommendations

Treated site for filamentous algae

Aquatic Services Report

Technician

Randy Mitchell

Job Details

Service Date	3/26/2026
Customer	Harbor Bay CDD
Weather Conditions	Sunny
Wind	E 6mph
Temperature	75
Multiple Sites Treated	Yes



Ponds Treated Information

Repeatable - 2 Count

1 of 2

Pond Numbers	All
Service Performed	Treatment
Work Performed	<input checked="" type="checkbox"/> Grasses
Equipment Used	<input checked="" type="checkbox"/> ATV/UTV
Water Level	Extremely Low
Restrictions	None
Observations/Recommendations	Treated sites for invasive vegetation growth (torpedo grass, pennywort, alligatorweed, cattails) as needed. Pond 6 has three planted cypress trees (see picture). Are they supposed to be there?

Pictures

Aquatic Services Report



Aquatic Services Report



Aquatic Services Report



2 of 2

Pond Numbers	8, 22
Service Performed	Treatment
Work Performed	<input checked="" type="checkbox"/> Algae
Equipment Used	<input checked="" type="checkbox"/> ATV/UTV
Water Level	Low
Restrictions	3 days
Observations/Recommendations	Treated sites for filamentous algae

Tab 4



Special Service Agreement

This Special Service Agreement, dated March 13, 2026, is made between **Blue Water Aquatics, Inc.** (hereinafter “Blue Water Aquatics”) located at 5119 State Road 54, New Port Richey, FL 34652, and **Harbor Bay CDD** (hereinafter the “Customer”), c/o Rizzetta & Company, Inc., 3434 Colwell Avenue, Suite 200, Tampa, FL 33614.

Project Site: Pond #2 –NORTH FOUNTAIN

General Conditions: Blue Water Aquatics will provide the following services:

1. Contract Services – Remove old fountain; Supply and install one (1) new Airmax® LakeSeries® Fountain.

Item A: KIT-654292 – This system comes with the Airmax® LakeSeries® 7½ HP, dual digital programmable control panel with dual digital timers, mooring kits and 200-feet of cord (8/4 with disconnect). The system also comes with Double Arch fountain pattern nozzle (Alternate patterns available).

Item B: STEP-UP TRANSFORMER – 208V to 203V step-up Transformer.

Item C: KIT-654203 – Airmax® RGBW composite LED 12-light kits (White, Red, Green, Blue and Amber) with RF remote with 200’ range that allows you to change colors, dim/brighten the lights, control flash speed, and run up to 9 preset programs.

Item D: Labor & Supplemental Materials – All material and labor are included.

2. Contract Costs: Customer agrees to pay Blue Water Aquatics, Inc. the following amount for these specific fountain installation services.

Item A:	Airmax® LakeSeries® Fountain System	\$ 29,870.72
Item B:	Step-Up Transformer	Included
Item C:	LED 12-Light Kit	Included
Item D:	Labor & Supplemental Materials	Included

TOTAL COST OF PROJECT:	\$ 29,870.72
-------------------------------	---------------------

The above price is effective for ninety (90) days from the date of this proposal.

Airmax Manufacturer Warranty: Fountain, Components & Light Kit – 5 years

The Customer acknowledges that weather conditions—including, but not limited to, rain, lightning, and wind—may delay the progress of the project. It is understood that the duration and severity of such weather events may impact the time required for Blue Water Aquatics to complete the work outlined in this Agreement. Blue Water Aquatics will use its best professional judgment to determine the appropriate services based on the conditions at the time. The company shall not be held responsible for any delays or failure to perform services caused by circumstances beyond its reasonable control.



Schedule and Payment Terms

The customer agrees to pay Blue Water Aquatics as follows:

- A **50% deposit** is required no later than **three (3) weeks prior to installation**.
- The **remaining 50%** is due within **thirty (30) days** of receiving the final installation invoice.

Accepted Payment Methods:

Cash, Money Order, Check, Zelle, ACH, or Credit Card. *Please note that credit card transactions will incur a 3% processing fee.*

Late Payment Terms:

Accounts past due by over **sixty (60) days** may result in the suspension of future services under this agreement. Interest will accrue on overdue balances at a rate of **1.5% per month** until paid in full.

Collections:

If Blue Water Aquatics initiates collection proceedings due to non-payment, the Customer agrees to reimburse all costs incurred, including reasonable attorney fees, court costs, and related expenses.

Disclaimer

Despite thorough site inspection, unforeseen conditions may arise during the course of work (e.g., hidden obstacles or environmental factors). Should such conditions require additional time or materials not covered in the original pricing, the Customer will be notified and invoiced for those costs.

Site Access and Authorization

By signing this agreement, the Customer affirms they either own the property or have the legal authority from the owner to authorize the services. If any ownership disputes arise, the Customer agrees to hold Blue Water Aquatics harmless.

A **staging area** for materials and equipment may be required. Blue Water Aquatics will utilize designated waterway access points.

Site Conditions and Preparation

The Customer affirms that all known site conditions relevant to the project have been disclosed, including (but not limited to): culverts, inverts, drains, trees, utilities (electric, gas, water), irrigation systems, embankments, physical obstructions, fences, gate codes, parking, and access points.

Photography and Documentation

The Customer grants Blue Water Aquatics permission to photograph or video the site during and after project completion for documentation or marketing purposes, at no additional cost.

Third-Party and Compliance Fees

The Customer agrees to reimburse Blue Water Aquatics for any third-party registration, compliance monitoring service fees, invoicing portal fees, or Waiver of Subordination fees incurred.



Insurance

Blue Water Aquatics carries coverage for:

- Workers' Compensation
- General Liability (with Umbrella Liability)
- Automotive Liability
- Property and Casualty
- Pollution Liability
- Marine Liability

A **Certificate of Insurance** can be provided upon request. If the Customer requires a waiver of subrogation, any related costs will be borne by the Customer.

E-Verify Compliance

Blue Water Aquatics uses the federal E-Verify system in compliance with Florida Statute 448.095. All terms and conditions of this statute are incorporated herein by reference.

Addenda: See attached map, survey, and report (where applicable).

*Christopher Thompson, President
Blue Water Aquatics, Inc.*

Customer Signature

Printed Name & Title

03/13/2026

Date

Date

**HARBOR BAY CDD
Fountain Map**

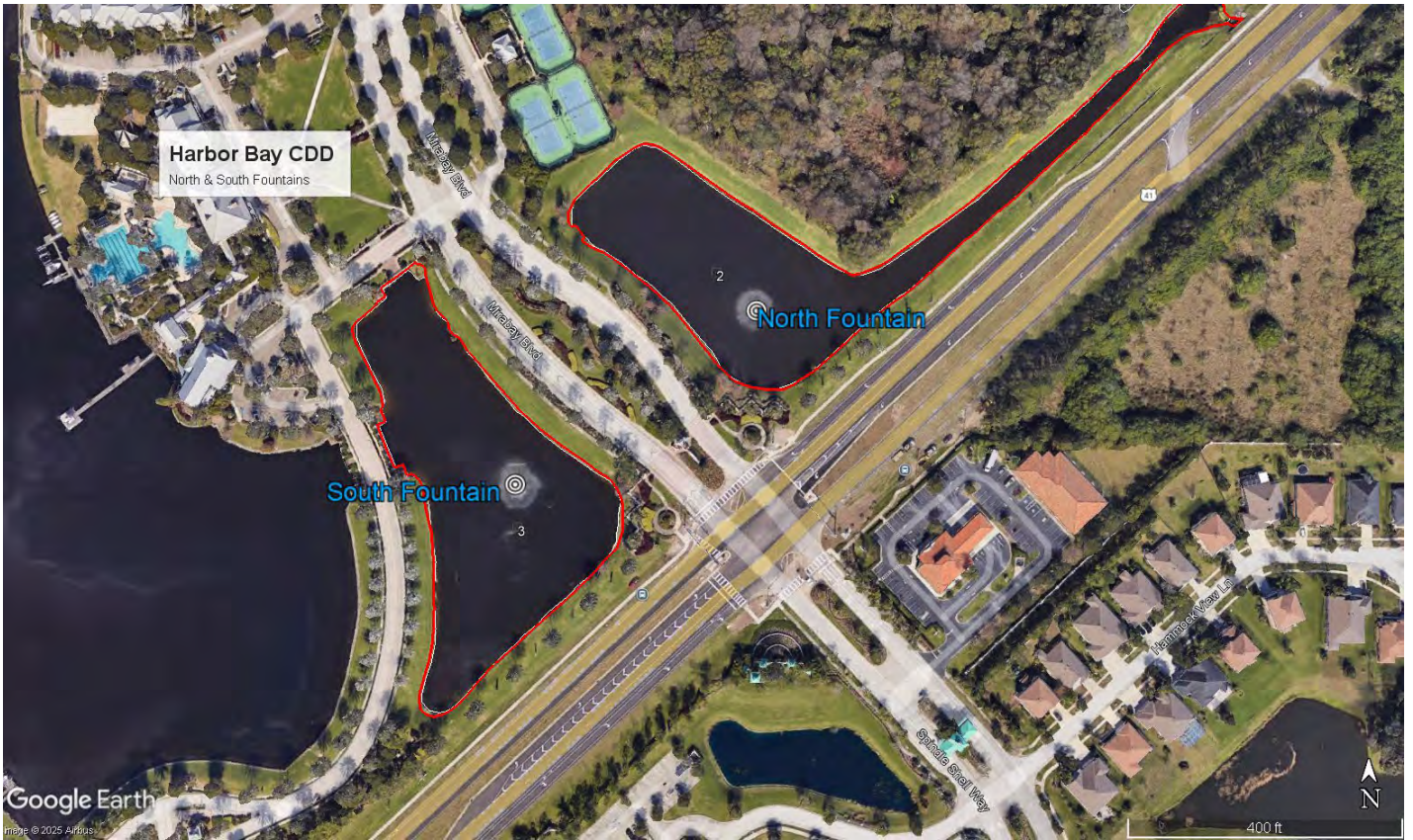

Double Arch Spray Pattern



Harbor Bay CDD-New NORTH Fountain Agreement 03-13-2026
HEADQUARTERS: 5119 State Road 54 ■ New Port Richey, FL 34652
Phone: 727-842-2100 ■ Email: Office@BlueWaterAquaticsInc.com

Airmax, Inc.

Airmax LakeSeries Fountain

Limited Warranty

Airmax, Inc. warrants to the original purchaser (the end user) of any Airmax LakeSeries Fountain manufactured by Airmax, Inc. that any component which proves to be defective in materials or workmanship, as determined by the factory within 5 years from the original purchased date, will be repaired or replaced at no charge with a new or remanufactured part, and returned freight prepaid. The end user shall assume all the responsibility and expense for removal, packaging, and freight to ship to Airmax, Inc. to determine the warranty claim and for all reinstallation expenses.

The warranty is void in cases where damage results from: improper installation, improper electrical connection, improper voltage, alteration, lightning, careless handling, misuse, abuse, disassembly of motor or failure to follow maintenance or operating instructions. Modification or repair by an unauthorized repair facility will void the warranty.

In no case will Airmax, Inc. or its dealers accept responsibility for any costs incurred by the user during installation, removal, inspection, evaluation, repair, parts replacement, or for return freight. Nor will any liability be accepted for loss of use, loss of profits, loss of goodwill, for consequential damage, or for personal injuries to the purchaser or any person.

In the event of problems believed to be covered under warranty, it will be necessary to notify the dealer who will try to help resolve the problem and who may contact the factory for additional assistance. If it is concluded that there may be a defect which may be covered under warranty, it will be necessary to get a Return Material Authorization (RMA) from the dealer before shipment. Freight collect shipments will not be accepted by the factory on warranties or repairs.

The product or part(s) must be returned freight prepaid, to the factory, as directed, and in its original packaging or in a container which will prevent damage. Parts returned under warranty and damaged during shipping will not be covered under warranty for the shipping damage. If the factory evaluation of the returned goods concludes that the failure is due to defects in materials or workmanship, the part or parts in question will be replaced under warranty with new parts, remanufactured parts, or will be repaired at the factory's option. The warranty period for all parts supplied under warranty will terminate at the end of the original product's warranty. All warranty shipments from the factory will be shipped freight prepaid.

Warranty registration is HIGHLY recommended.

No implied warranties of any kind are made by Airmax, Inc. for its products, and no other warranties, whether expressed or implied, including implied warranties of merchantability and fitness for a particular purpose, shall apply. Should an Airmax, Inc. product prove to be defective in materials or workmanship, the retail purchaser's sole remedy shall be repair or replacement of the product as expressly provided above.

The manufacturer's warranty will begin from the dealer's original purchase date if the product is not registered. To register a product, you are required to fill out the warranty registration form at airmaxeco.com/warranty. Warranty registration must be submitted directly to Airmax within 30 days of the end-user's purchase date.

LakeSeries® 7.5 & 10 HP Fountain

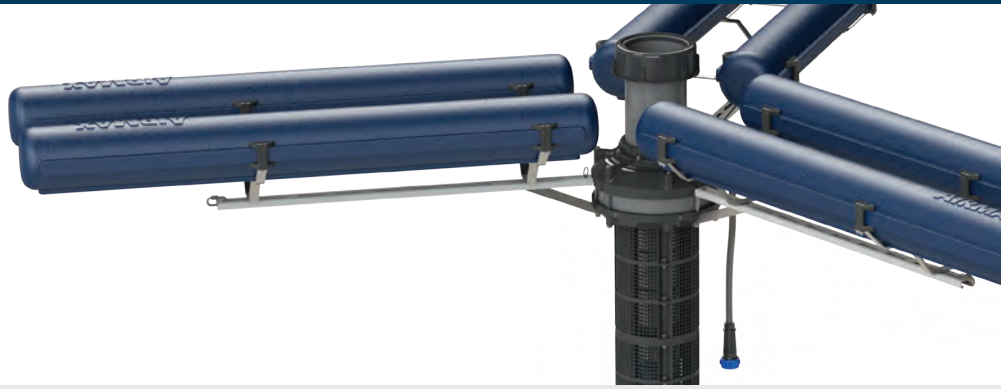

Fountain Kits Include:

- Energy Efficient, Fully Sealed, UL Approved Motor
- 230v 3 PH or 460v 3 PH Control Panel with Two Digital Timers for Fountain & Optional Lights
- Power Cord with Strain Relief
- Underwater Quick Disconnect
- 5 Year Warranty

Professional-Grade Design for Maximum Height, Scale & Stability



Airmax has further expanded our fountain lineup by launching the innovative LakeSeries 7.5 HP and 10 HP models. These fountains represent our largest units to date, delivering impressive height and scale. Featuring the twin ISP Float System for unmatched stability and tool-free installation, LakeSeries fountains are the lightest and most compact large horsepower options available, eliminating the need for bulky equipment and extensive manpower. With quick and easy installation requiring only 1-2 technicians and no heavy machinery, the LakeSeries offers convenience, efficiency, and performance never seen before.

Airmax LakeSeries 3 PH - 7.5 & 10 HP Fountain Kit (No Power Cord Included)

HP	Description				
7.5 & 10 HP	HP/Volts	7.5 HP 230v	10 HP 230v	7.5 HP 460v	10 HP 460v
	AMPS	24A	32A	12A	16A
	Min. Operating Depth	48	48	48	48
	Item #	654292	654293	654286	654287

Fountain Pattern Dimensions (H' x W')

HP	Classic	Trumpet	Crown & Trumpet		Gusher	Crown & Gusher		Single Arch	Double Arch	
			Trumpet	Crown		Gusher	Crown		1st Tier	2nd Tier
7.5	-	35 x 18	28 x 12	14 x 60	40	26	15 x 75	25 x 68	26 x 40	12.5 x 85
10	-	40 x 20	34 x 16	16 x 65	50	32	17 x 100	35 x 80	32 x 50	15 x 95

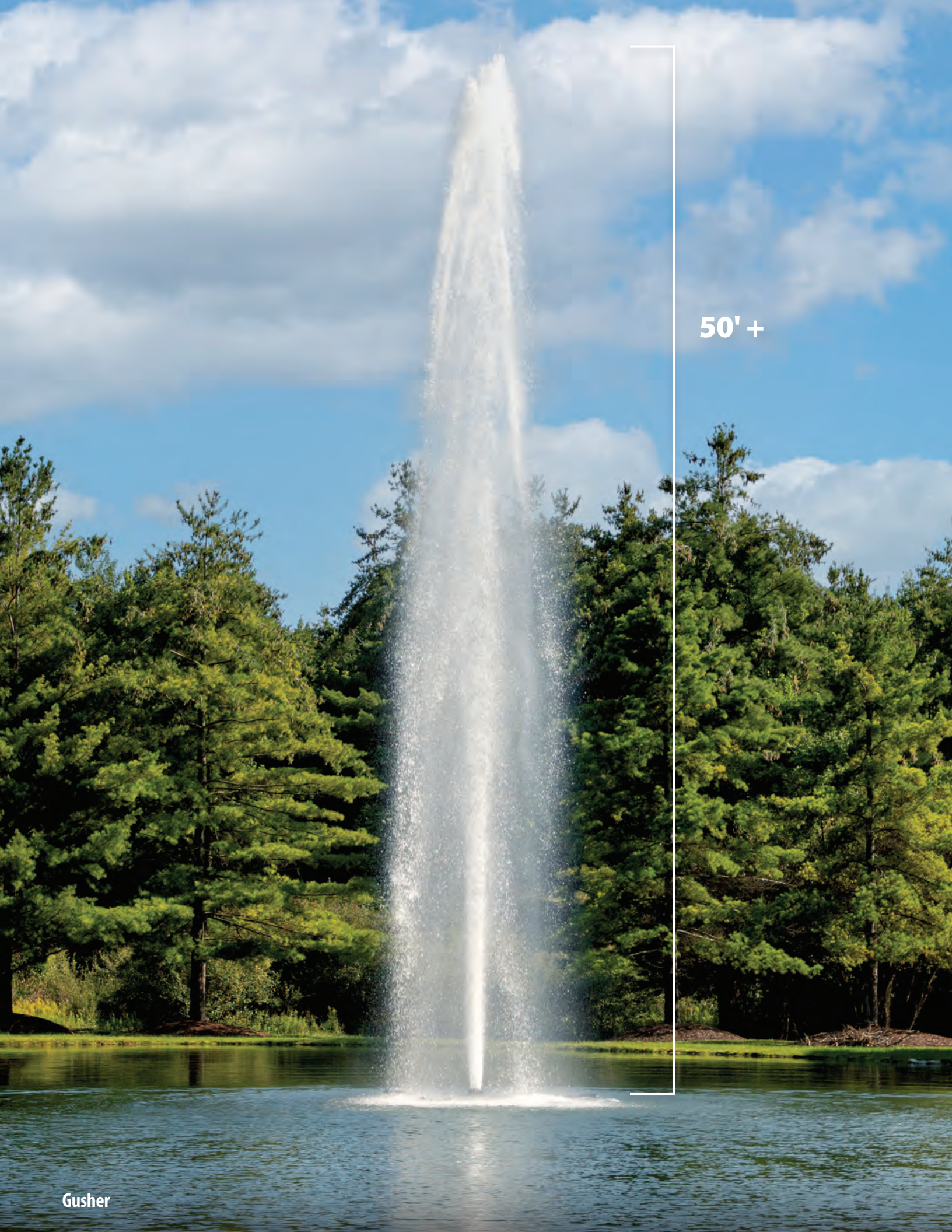

50' +

Gusher



LakeSeries® Nozzles

7.5 & 10 HP

Available LakeSeries Nozzles (minimum 1 required at the time of purchase).

Airmax LakeSeries Fountain Nozzles			
Description	HP		Item #
Crown & Gusher Nozzle	7.5 HP		653538
Crown & Gusher Nozzle	10 HP		653543
Crown & Trumpet Nozzle	7.5 HP		653537
Crown & Trumpet Nozzle	10 HP		653542
Gusher Nozzle	7.5 HP		653539
Gusher Nozzle	10 HP		653544
Trumpet Nozzle	7.5 HP		653536
Trumpet Nozzle	10 HP		653541
NEW! Single Arch Nozzle	7.5 & 10 HP		653429
NEW! Double Arch Nozzle	7.5 & 10 HP		653428



Crown & Gusher



Crown & Trumpet



Gusher



Trumpet



RGBW Color-Changing Lights

RF Remote with 200' Range



- Energy Efficient High Output LED, 120 Volt
- Completely Sealed, Adjustable Above Waterline Design for Low Maintenance
- All Light Sets Include Stainless-Steel Braiding on Power Lead and Between Light Fixtures
- Power Cords Come Standard with Strain Relief and Underwater Disconnect; 100' - 600' Lengths. Also Available with Stainless-Steel and Polyflex Protected Cords
- RF Remote with 200' Range is Included with All RGBW Color-Changing Light Sets
- Compatible With All Manufacturers' Fountains
- EcoSeries & PondSeries available in 2, 4 & 8 LED Light Sets
- LakeSeries Available in 9 & 12 LED Light Sets
- 3-Year Warranty



Sealed Adjustable Light Fixtures with an Easy Snap-on Design

Adjustable Color Temperature

Broader range of Kelvin allows for changes from cool white to warm white, and vibrant colors to pastels.



Warm White



Cool White



Pastel Blue



Vibrant Blue



Pastel Green



Vibrant Green



RGBW Lights 2700-6500K



Special Service Agreement

This Special Service Agreement, dated March 13, 2026, is made between **Blue Water Aquatics, Inc.** (hereinafter “Blue Water Aquatics”) located at 5119 State Road 54, New Port Richey, FL 34652, and **Harbor Bay CDD** (hereinafter the “Customer”), c/o Rizzetta & Company, Inc., 3434 Colwell Avenue, Suite 200, Tampa, FL 33614.

Project Site: Pond #3 –SOUTH FOUNTAIN

General Conditions: Blue Water Aquatics will provide the following services:

1. Contract Services – Remove old fountain; Supply and install one (1) new Airmax® LakeSeries® Fountain.

Item A: KIT-654292 – This system comes with the Airmax® LakeSeries® 7½ HP, dual digital programable control panel with dual digital timers, mooring kits and 200-feet of cord (8/4 with disconnect). The system also comes with Double Arch fountain pattern nozzle (Alternate patterns available).

Item B: STEP-UP TRANSFORMER – 208V to 203V step-up Transformer.

Item C: KIT-654203 – Airmax® RGBW composite LED 12-light kits (White, Red, Green, Blue and Amber) with RF remote with 200’ range that allows you to change colors, dim/brighten the lights, control flash speed, and run up to 9 preset programs.

Item D: Labor & Supplemental Materials – All material and labor are included.

2. Contract Costs: Customer agrees to pay Blue Water Aquatics, Inc. the following amount for these specific fountain installation services.

Item A:	Airmax® LakeSeries® Fountain System	\$ 29,870.72
Item B:	Step-Up Transformer	Included
Item C:	LED 12-Light Kit	Included
Item D:	Labor & Supplemental Materials	Included

TOTAL COST OF PROJECT:	\$ 29,870.72
-------------------------------	---------------------

The above price is effective for ninety (90) days from the date of this proposal.

Airmax Manufacturer Warranty: Fountain, Components & Light Kit – 5 years

The Customer acknowledges that weather conditions—including, but not limited to, rain, lightning, and wind—may delay the progress of the project. It is understood that the duration and severity of such weather events may impact the time required for Blue Water Aquatics to complete the work outlined in this Agreement. Blue Water Aquatics will use its best professional judgment to determine the appropriate services based on the conditions at the time. The company shall not be held responsible for any delays or failure to perform services caused by circumstances beyond its reasonable control.



Schedule and Payment Terms

The customer agrees to pay Blue Water Aquatics as follows:

- A **50% deposit** is required no later than **three (3) weeks prior to installation**.
- The **remaining 50%** is due within **thirty (30) days** of receiving the final installation invoice.

Accepted Payment Methods:

Cash, Money Order, Check, Zelle, ACH, or Credit Card. *Please note that credit card transactions will incur a 3% processing fee.*

Late Payment Terms:

Accounts past due by over **sixty (60) days** may result in the suspension of future services under this agreement. Interest will accrue on overdue balances at a rate of **1.5% per month** until paid in full.

Collections:

If Blue Water Aquatics initiates collection proceedings due to non-payment, the Customer agrees to reimburse all costs incurred, including reasonable attorney fees, court costs, and related expenses.

Disclaimer

Despite thorough site inspection, unforeseen conditions may arise during the course of work (e.g., hidden obstacles or environmental factors). Should such conditions require additional time or materials not covered in the original pricing, the Customer will be notified and invoiced for those costs.

Site Access and Authorization

By signing this agreement, the Customer affirms they either own the property or have the legal authority from the owner to authorize the services. If any ownership disputes arise, the Customer agrees to hold Blue Water Aquatics harmless.

A **staging area** for materials and equipment may be required. Blue Water Aquatics will utilize designated waterway access points.

Site Conditions and Preparation

The Customer affirms that all known site conditions relevant to the project have been disclosed, including (but not limited to): culverts, inverts, drains, trees, utilities (electric, gas, water), irrigation systems, embankments, physical obstructions, fences, gate codes, parking, and access points.

Photography and Documentation

The Customer grants Blue Water Aquatics permission to photograph or video the site during and after project completion for documentation or marketing purposes, at no additional cost.

Third-Party and Compliance Fees

The Customer agrees to reimburse Blue Water Aquatics for any third-party registration, compliance monitoring service fees, invoicing portal fees, or Waiver of Subordination fees incurred.



Insurance

Blue Water Aquatics carries coverage for:

- Workers' Compensation
- General Liability (with Umbrella Liability)
- Automotive Liability
- Property and Casualty
- Pollution Liability
- Marine Liability

A **Certificate of Insurance** can be provided upon request. If the Customer requires a waiver of subrogation, any related costs will be borne by the Customer.

E-Verify Compliance

Blue Water Aquatics uses the federal E-Verify system in compliance with Florida Statute 448.095. All terms and conditions of this statute are incorporated herein by reference.

Addenda: See attached map, survey, and report (where applicable).

*Christopher Thompson, President
Blue Water Aquatics, Inc.*

Customer Signature

Printed Name & Title

03/13/2026
Date

Date

**HARBOR BAY CDD
Fountain Map**

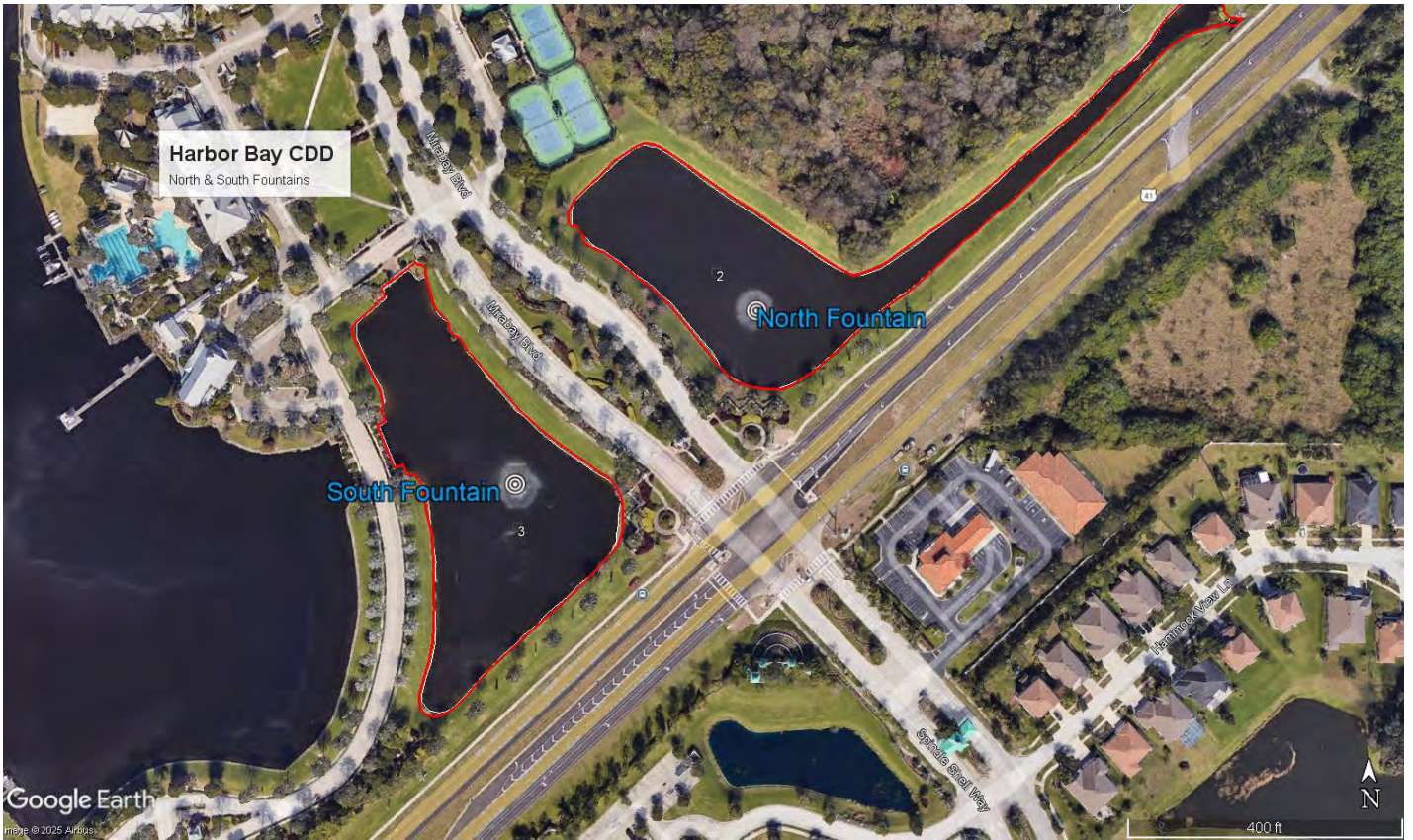

Double Arch Spray Pattern



Harbor Bay CDD-New SOUTH Fountain Agreement 03-13-2026
HEADQUARTERS: 5119 State Road 54 ■ New Port Richey, FL 34652
Phone: 727-842-2100 ■ Email: Office@BlueWaterAquaticsInc.com

Airmax, Inc.

Airmax LakeSeries Fountain

Limited Warranty

Airmax, Inc. warrants to the original purchaser (the end user) of any Airmax LakeSeries Fountain manufactured by Airmax, Inc. that any component which proves to be defective in materials or workmanship, as determined by the factory within 5 years from the original purchased date, will be repaired or replaced at no charge with a new or remanufactured part, and returned freight prepaid. The end user shall assume all the responsibility and expense for removal, packaging, and freight to ship to Airmax, Inc. to determine the warranty claim and for all reinstallation expenses.

The warranty is void in cases where damage results from: improper installation, improper electrical connection, improper voltage, alteration, lightning, careless handling, misuse, abuse, disassembly of motor or failure to follow maintenance or operating instructions. Modification or repair by an unauthorized repair facility will void the warranty.

In no case will Airmax, Inc. or its dealers accept responsibility for any costs incurred by the user during installation, removal, inspection, evaluation, repair, parts replacement, or for return freight. Nor will any liability be accepted for loss of use, loss of profits, loss of goodwill, for consequential damage, or for personal injuries to the purchaser or any person.

In the event of problems believed to be covered under warranty, it will be necessary to notify the dealer who will try to help resolve the problem and who may contact the factory for additional assistance. If it is concluded that there may be a defect which may be covered under warranty, it will be necessary to get a Return Material Authorization (RMA) from the dealer before shipment. Freight collect shipments will not be accepted by the factory on warranties or repairs.

The product or part(s) must be returned freight prepaid, to the factory, as directed, and in its original packaging or in a container which will prevent damage. Parts returned under warranty and damaged during shipping will not be covered under warranty for the shipping damage. If the factory evaluation of the returned goods concludes that the failure is due to defects in materials or workmanship, the part or parts in question will be replaced under warranty with new parts, remanufactured parts, or will be repaired at the factory's option. The warranty period for all parts supplied under warranty will terminate at the end of the original product's warranty. All warranty shipments from the factory will be shipped freight prepaid.

Warranty registration is HIGHLY recommended.

No implied warranties of any kind are made by Airmax, Inc. for its products, and no other warranties, whether expressed or implied, including implied warranties of merchantability and fitness for a particular purpose, shall apply. Should an Airmax, Inc. product prove to be defective in materials or workmanship, the retail purchaser's sole remedy shall be repair or replacement of the product as expressly provided above.

The manufacturer's warranty will begin from the dealer's original purchase date if the product is not registered. To register a product, you are required to fill out the warranty registration form at airmaxeco.com/warranty. Warranty registration must be submitted directly to Airmax within 30 days of the end-user's purchase date.

LakeSeries® 7.5 & 10 HP Fountain

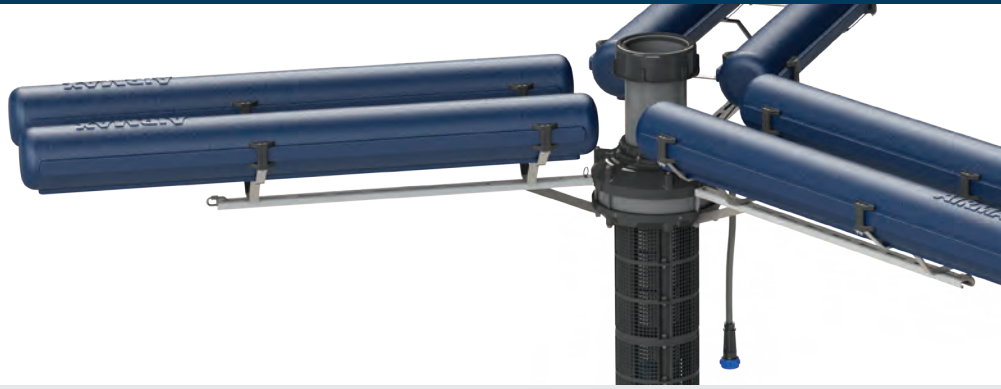

Fountain Kits Include:

- Energy Efficient, Fully Sealed, UL Approved Motor
- 230v 3 PH or 460v 3 PH Control Panel with Two Digital Timers for Fountain & Optional Lights
- Power Cord with Strain Relief
- Underwater Quick Disconnect
- 5 Year Warranty

Professional-Grade Design for Maximum Height, Scale & Stability



Airmax has further expanded our fountain lineup by launching the innovative LakeSeries 7.5 HP and 10 HP models. These fountains represent our largest units to date, delivering impressive height and scale. Featuring the twin ISP Float System for unmatched stability and tool-free installation, LakeSeries fountains are the lightest and most compact large horsepower options available, eliminating the need for bulky equipment and extensive manpower. With quick and easy installation requiring only 1-2 technicians and no heavy machinery, the LakeSeries offers convenience, efficiency, and performance never seen before.

Airmax LakeSeries 3 PH - 7.5 & 10 HP Fountain Kit (No Power Cord Included)

HP	Description				
7.5 & 10 HP	HP/Volts	7.5 HP 230v	10 HP 230v	7.5 HP 460v	10 HP 460v
	AMPS	24A	32A	12A	16A
	Min. Operating Depth	48	48	48	48
	Item #	654292	654293	654286	654287

Fountain Pattern Dimensions (H' x W')

HP	Classic	Trumpet	Crown & Trumpet		Gusher	Crown & Gusher		Single Arch	Double Arch	
			Trumpet	Crown		Gusher	Crown		1st Tier	2nd Tier
7.5	-	35 x 18	28 x 12	14 x 60	40	26	15 x 75	25 x 68	26 x 40	12.5 x 85
10	-	40 x 20	34 x 16	16 x 65	50	32	17 x 100	35 x 80	32 x 50	15 x 95

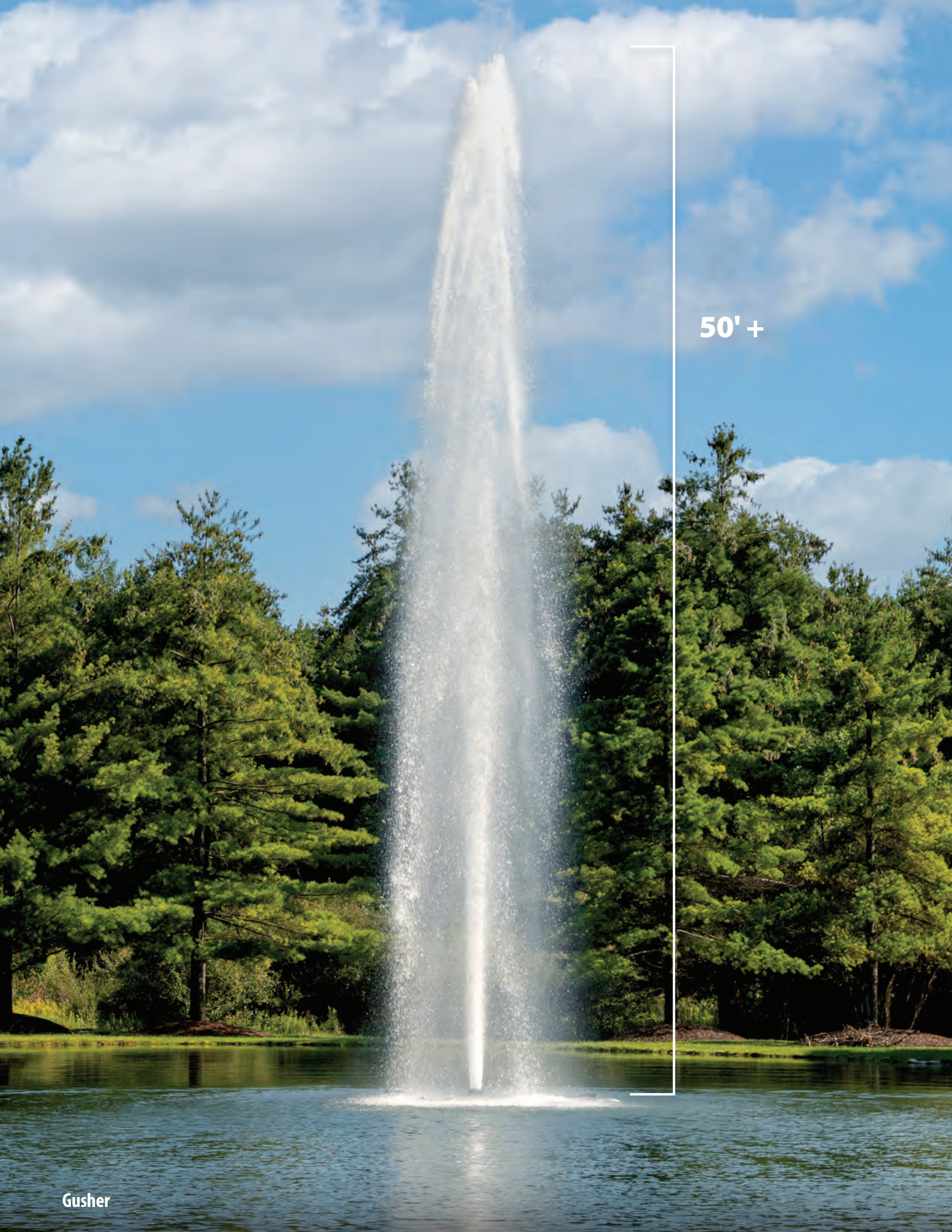

50' +

Gusher



LakeSeries[®] Nozzles

7.5 & 10 HP

Available LakeSeries Nozzles (minimum 1 required at the time of purchase).

Airmax LakeSeries Fountain Nozzles			
Description	HP		Item #
Crown & Gusher Nozzle	7.5 HP		653538
Crown & Gusher Nozzle	10 HP		653543
Crown & Trumpet Nozzle	7.5 HP		653537
Crown & Trumpet Nozzle	10 HP		653542
Gusher Nozzle	7.5 HP		653539
Gusher Nozzle	10 HP		653544
Trumpet Nozzle	7.5 HP		653536
Trumpet Nozzle	10 HP		653541
NEW! Single Arch Nozzle	7.5 & 10 HP		653429
NEW! Double Arch Nozzle	7.5 & 10 HP		653428



Crown & Gusher



Crown & Trumpet



Gusher



Trumpet



RGBW Color-Changing Lights

RF Remote with 200' Range



- Energy Efficient High Output LED, 120 Volt
- Completely Sealed, Adjustable Above Waterline Design for Low Maintenance
- All Light Sets Include Stainless-Steel Braiding on Power Lead and Between Light Fixtures
- Power Cords Come Standard with Strain Relief and Underwater Disconnect; 100' - 600' Lengths. Also Available with Stainless-Steel and Polyflex Protected Cords
- RF Remote with 200' Range is Included with All RGBW Color-Changing Light Sets
- Compatible With All Manufacturers' Fountains
- EcoSeries & PondSeries available in 2, 4 & 8 LED Light Sets
- LakeSeries Available in 9 & 12 LED Light Sets
- 3-Year Warranty



Sealed Adjustable Light Fixtures with an Easy Snap-on Design

Adjustable Color Temperature

Broader range of Kelvin allows for changes from cool white to warm white, and vibrant colors to pastels.



Warm White



Cool White



Pastel Blue



Vibrant Blue



Pastel Green



Vibrant Green



RGBW Lights 2700-6500K

Fountain Installation Agreement

This Fountain Installation Agreement (“Agreement”) is entered into as of _____, by and between **Steadfast**, which may include Steadfast Contractors Alliance, LLC and/or Steadfast Environmental, LLC (collectively, “Steadfast”), and **Harbor Bay CDD** (“Customer”).

Steadfast and Customer may be referred to individually as a “Party” and collectively as the “Parties.”

1. General Conditions

Steadfast shall furnish all labor, materials, equipment, and supervision necessary to install the fountain system(s) described in this Agreement in a professional and workmanlike manner. Customer agrees to compensate Steadfast in accordance with the terms set forth herein.

2. Service Area

Installation services shall be performed at the following waterbody or waterbodies: (“Service Area”):

Pond 1, Pond 2

3. Fountain Systems to Be Installed

Steadfast shall install the following fountain system(s):

Location	Make/Model	Lighting Included	Installation Price
Pond 1	Kasco 7.3JF250	Y	\$39,270.00
Pond 2	Kasco 7.3JF250	Y	\$39,270.00

Total Agreement Amount: \$78,540.00

4. Scope of Installation (Included)

The installation price includes the following services, as applicable to each system listed above:

- Placement and anchoring of floating fountain unit(s)
 - Installation of pump and motor assemblies
 - Installation of float assemblies and intake screens
 - Installation of lighting fixtures, lenses, and seals (if applicable)
 - Connection to Customer-provided electrical source
 - Initial startup and verification of basic operation at the time of installation
-

5. Assumptions and Site Conditions

Installation pricing and scheduling are based on the following assumptions:

- Electrical power is **provided by Customer**, available at each fountain location, and meets manufacturer specifications
- Electrical trenching, conduit installation, panel upgrades, permitting, or inspections are excluded unless expressly stated in writing
- Water levels are sufficient for proper placement and operation of the fountain system(s)
- Reasonable access is provided for personnel, vessels, and installation equipment

Steadfast shall not be responsible for delays, additional costs, or system performance issues caused by unmet site conditions.

6. Exclusions (Not Included)

Unless expressly stated otherwise in this Agreement, the following are excluded:

- Electrical work beyond final connection
 - Structural, plumbing, or shoreline modifications
 - Removal or disposal of existing fountain systems
 - Long-term operation monitoring or routine maintenance
 - Performance guarantees related to circulation, aesthetics, algae control, or water quality outcomes
-

7. Payment Terms

The total Agreement Amount shall be invoiced upon completion of installation services unless otherwise stated in writing.

Payment is due within **thirty (30) days** of the invoice date. Any balance remaining unpaid more than **sixty (60) days** after the invoice date shall accrue a service charge of **one percent (1%) per month (twelve percent (12%) per annum)** on the unpaid balance.

8. Accepted Forms of Payment

Steadfast accepts payment by **check, ACH transfer, debit card, or credit card**, unless otherwise agreed in writing.

9. Credit and Debit Card Processing Fees

Invoices paid by credit or debit card shall be subject to a **three percent (3%) processing fee**, which will be added to the invoice total.

10. Contract Void Ab Initio

This Agreement shall be void ab initio if Steadfast determines, in its sole discretion, that the condition of the Service Area has materially deteriorated between the date of this Agreement and the commencement of installation services. This provision shall not apply once installation services have commenced.

11. Force Majeure

Steadfast shall not be liable for delays or failure to perform caused by events beyond its reasonable control, including weather conditions, site inaccessibility, utility interruptions, equipment availability, or governmental actions.

12. Safety and Property Protection

Steadfast shall use commercially reasonable care, appropriate equipment, and professional methods in performing installation services. Customer acknowledges that installation activities may involve temporary and unavoidable disturbance to the Service Area. Steadfast shall not be liable for incidental impacts resulting from properly performed installation work.

13. Warranty and Limitation of Responsibility

All fountain equipment installed under this Agreement is subject solely to the manufacturer's warranty. Steadfast does not modify, extend, or replace manufacturer warranties.

Kasco Warranty: FOUNTAIN Seller warrants fountain to be free from defects and workmanship for a period of 3 years from receipt, lighting system 2 years and controls 1 year. Liability limited solely to replacement or repair of product and not any loss, damages or expenses directly or indirectly arising in connection with the purchase or use of the product. Parts warranty only.

Warranty determination of defective parts shall be responsibility of the Seller. If inspection indicates failure due to lack of required maintenance (as outlined in Operation & Maintenance manual), alteration of original equipment, failure to maintain proper voltage or incorrect installation, warranty shall be void.

Steadfast warrants that installation labor will be performed in a professional and workmanlike manner consistent with industry standards. This Agreement does not include ongoing maintenance, monitoring, or repairs unless covered under a separate written agreement.

14. Insurance and Limitation of Liability

Steadfast shall maintain insurance appropriate to the scope of work performed. Each Party shall be responsible only for damages arising from its own negligence or willful misconduct. In no event shall either Party be liable for incidental, consequential, or purely economic damages.

15. Governing Law and Enforcement

This Agreement shall be governed by and construed in accordance with the laws of the State of Florida. In the event of default, the non-defaulting Party shall be entitled to pursue all remedies available at law or in equity.

16. E-Verify Compliance

Steadfast complies with Florida Statute 448.095 and participates in the federal E-Verify program where required. All applicable statutory provisions are incorporated herein by reference.

17. Proposal Validity

This proposal shall remain valid for **sixty (60) days** from the date of issuance unless modified in writing by Steadfast.

Acceptance and Authorization

By signing below, the Parties acknowledge and agree to the terms and conditions of this Agreement.

Harbor Bay CDD:

Name: _____

Signature: _____

Title: _____

Date: _____

Address for Notice Purposes:

Steadfast:

Name: Kevin Riemensperger

Signature: *Kevin Riemensperger*

Title: Aquatics Division Manager

Date: 4/7/26

Remit Payments and Executed Agreements To:

Steadfast Contractor's Alliance, LLC

30435 Commerce Drive, Suite 102

San Antonio, FL 33576

Fountain Maintenance Services Agreement

This Fountain Maintenance Services Agreement (“Agreement”) is entered into as of _____ (“Effective Date”), by and between **Steadfast**, which may include Steadfast Contractors Alliance, LLC and/or Steadfast Environmental, LLC (collectively referred to herein as “Steadfast”), and **Harbor Bay CDD** (“Customer”).

Steadfast and Customer may be referred to individually as a “Party” and collectively as the “Parties.”

1. Scope of Agreement

Steadfast shall provide routine fountain maintenance services as described herein in a professional and workmanlike manner. Customer agrees to compensate Steadfast for such services in accordance with the terms of this Agreement.

2. Service Equipment

The equipment covered under this Agreement (“Service Equipment”) consists of **(2) Kasco Kasco 7.3JF250 floating fountains located on Pond 1 & Pond 2.**

3. Services Provided

Steadfast shall perform **twenty four (24) scheduled inspections per year** of the Service Equipment. Services shall include, as applicable:

a. Fountain Maintenance Services

- Perform amp testing on fountain motors to verify proper load
- Verify incoming and outgoing voltage
- Test motor GFCI, contactor (starter), and overload protection
- Inspect and verify condition of fuses, breakers, wiring, and electrical connections
- Inspect and adjust operational timers as necessary
- Test lighting GFCI breakers and lighting timers
- Inspect propeller or impeller and diffuser plates (if applicable) for damage or improper attachment
- Clean debris screens, nozzles, shafts, and pump chambers to ensure adequate water flow
- Clean lighting lenses

- Replace leaking light housing seals

If diagnostic testing indicates abnormal operation or malfunction, Steadfast may conduct additional electrical testing, including ohm testing of power cables between the control panel and motor.

b. Replacement Parts and Repairs

Replacement parts and labor not covered under manufacturer warranty shall be billed at additional cost. Warranty-covered repairs shall be performed at no cost to the Customer.

If Steadfast identifies repairs requiring substantial labor or materials beyond routine maintenance and not covered under warranty, Steadfast shall notify Customer and obtain approval prior to performing such work. Steadfast may invoice up to **\$500.00** in additional parts during any maintenance visit without prior written approval.

c. Troubleshooting and Extra Visits

Visits outside the scheduled maintenance cycle shall be considered troubleshooting services and billed at a **\$100.00 service fee**, plus labor at **\$135.00 per hour** and materials. Any visit occurring **fourteen (14) days or more** after a scheduled maintenance visit shall be deemed a troubleshooting visit.

4. Term and Automatic Renewal

This Agreement shall remain in effect for an initial term of **one (1) year** from the Effective Date. The Agreement shall automatically renew for successive one-year terms unless terminated in accordance with this Agreement. Upon each renewal, pricing may be adjusted with written notice.

5. Fees and Payment Terms

The total Annual Agreement Amount is **\$12,960.00**, billed in **monthly installments of \$1,080.00**, commencing on the first day of the month following the start of services.

Invoices are due within **thirty (30) days** of the invoice date. Any balance unpaid after **sixty (60) days** shall accrue a service charge of **1% per month (12% annually)**.

5.1 Suspension of Services for Non-Payment

Steadfast reserves the right, upon written notice, to suspend some or all Services if any undisputed invoice remains unpaid for more than **thirty (30) days past its due date**. Suspension of Services shall not constitute termination of this Agreement.

Steadfast shall not be liable for any damages, deterioration, aesthetic conditions, operational issues, regulatory concerns, or other consequences arising from a suspension due to non-payment. Services shall resume only after all outstanding balances, including

applicable service charges, have been paid in full. Customer's payment obligations shall survive any suspension.

6. Accepted Forms of Payment

Payment shall be made by check unless otherwise agreed to in writing.

7. Condition of Service Area

This Agreement shall be void ab initio if Steadfast determines, prior to commencement of services, that the condition of the Service Equipment or service area has materially deteriorated. This provision shall not apply once Steadfast has commenced services.

8. Force Majeure

Steadfast shall not be responsible for delays or failure to perform due to causes beyond its reasonable control, including acts of God, weather events, utility interruptions, or governmental actions.

9. Customer Contact Information

Customer is responsible for providing and maintaining accurate contact and billing information and shall notify Steadfast of any changes within **thirty (30) days**.

10. Termination

Either Party may terminate this Agreement with **thirty (30) days' written notice**, with services continuing through the end of the month in which the notice period expires.

All notices shall be sent by Certified Mail to:

Steadfast Contractor's Alliance, LLC

30435 Commerce Drive, Suite 102

San Antonio, FL 33576

11. Governing Law and Enforcement

This Agreement shall be governed by and construed in accordance with the laws of the State of Florida. Each Party shall be entitled to pursue all remedies available at law or equity in the event of default.

12. Safety and Standard of Care

Steadfast shall utilize appropriate equipment, materials, and procedures and exercise reasonable care in performing services. Steadfast shall take commercially reasonable steps to protect Customer property.

13. Additional Services

Services outside the scope of this Agreement, including debris removal, vegetation cutting, or other specialty services, shall be performed only under a separate written agreement.

14. Insurance and Limitation of Liability

Steadfast shall maintain insurance appropriate to the services performed. Each Party shall be responsible only for damages arising from its own negligence or misconduct. Neither Party shall be liable for incidental, consequential, or purely economic damages.

15. E-Verify Compliance

Steadfast complies with Florida Statute 448.095 and participates in the federal E-Verify program where required.

16. Proposal Validity

This proposal shall remain valid for **sixty (60) days** from issuance unless modified in writing by Steadfast.

Agreement Summary

Annual Agreement Amount: \$12,960.00

Quarterly Invoice Amount: \$1,080.00

Billing Frequency: Quarterly

Acceptance

Harbor Bay CDD

Signature:

Printed Name:

Title:

Date:

Address for Notice Purposes:

Steadfast

Signature: *Kevin Riemensperger*

Printed Name: Kevin Riemensperger

Title: Aquatics Division Manager

Date: 4/7/26

Remit Payments and Executed Agreements To:

Steadfast Contractor's Alliance, LLC

30435 Commerce Drive, Suite 102

San Antonio, FL 33576

Tab 5

MONTHLY STATUS REPORT

LEE TE KIM LANDSCAPE & LAWN CARE, INC.

127 16TH AVENUE SW
RUSKIN, FL 33570
(813) 645-1769 OFFICE

DATE: APRIL 6, 2026

REPORT SUBMITTED TO:

HARBOR BAY CDD
C/O RIZZETTA & COMPANY, INC.
3434 COLWELL AVE., SUITE 200
TAMPA, FL 33614

WORK PERFORMED FROM 03/09/2026-04/06/2026:

IRRIGATION: A recent records request asking for the "report" relative to the Water Usage Reporting contract brought to our attention that some clarification of what this reporting involves may be necessary. The following steps are taken each month when reporting water usage:

Water Usage Reporting isn't a specific report, it is the reporting of water usage. The process entails going to the (10) different withdrawal points.

At each one of the (**10) withdrawal points we take a photo and the numeric number from the meter. Based on that number in relation to the type of meter that is on that withdrawal point, we determine the reading and calculate the gallons pumped that month.

We go onto the Southwest Florida Water Management District website and submit the following data:

Remark

Meter Read Date

Meter Reading

Gallons Pumped

There is also a comment portion that can be filled out if circumstances warrant same.

The meter readings must be reported by the 5th day of each month.

As part of the special conditions for this water usage permit, there is an Annual Recreation Crop Report that must be completed. This "report" is also submitted via the Southwest Florida Water Management District website. This report includes the following information: Soil Type, whether this withdrawal point was used, was this for Recreation or Aesthetic Use, Total Acres and How many Acres are Landscaped.

** Currently there are only 9 Withdrawal points in use

PAGE 2

TURFGRASS MANAGEMENT: We are back on track with the mowing, weeding, trimming, applying fertilizers and spraying for bugs schedule. We also had the Fire Ant Specialists brought in for treatment in preparation for Spring Break and the upcoming Summer Camp.

The Clubhouse project was completed last week which entailed Removing (12) dead Triple Stem Christmas Palms, installing (10) King Alexander Palms and (2) Triple Stem King Alexander Palms. The Mirabay Entryway project is nearing completion, even with an additional (264) plants being installed at no additional expense to the community. Palm Tree Trimming has been taking place along with a changing of the Annual Plants from Pansy to Vinca. Up next we will be putting mulch in throughout the community.

MIRABAY LANDSCAPING STATUS REPORT

LEE TE KIM LANDSCAPE & LAWN CARE, INC.

127 16TH AVENUE SW

RUSKIN, FL 33570

(813) 645-1769 OFFICE

(813) 645-7314 FAX

DATE: MARCH 16, 2026

PROPOSAL SUBMITTED TO:

HARBOR BAY CDD

C/O RIZZETTA & COMPANY, INC.

3434 COLWELL AVE., SUITE 200

TAMPA, FL 33614

WORK PERFORMED – WEEK OF 3/09/2026

- Admiral Point Drive
 - Balibay Road
 - Golden Isle Drive
 - Ibis View Lane
 - Islebay Drive
 - Manns Harbor Drive
 - Mirabay Blvd.
 - Pinckney Drive
 - Skimmer Drive
 - Wishing Arch Drive
 - Berm along SR 41
 - Club
 - Lee Te Kim Park
 - Playground
 - Tennis Courts
-
- Trimmed bushes and palm trees in multiple locations listed above.
 - Hand pulled weed and cleaned up plant beds in multiple locations listed above.
 - Picked up trash in multiple locations listed above.

MIRABAY LANDSCAPING STATUS REPORT

LEE TE KIM LANDSCAPE & LAWN CARE, INC.

127 16TH AVENUE SW

RUSKIN, FL 33570

(813) 645-1769 OFFICE

(813) 645-7314 FAX

DATE: MARCH 23, 2026

PROPOSAL SUBMITTED TO:

HARBOR BAY CDD

C/O RIZZETTA & COMPANY, INC.

3434 COLWELL AVE., SUITE 200

TAMPA, FL 33614

WORK PERFORMED – WEEK OF 3/16/2026

- Admiral Point Drive
 - Balibay Road
 - Beacon Sound
 - Golden Isle Drive
 - Ibis View Lane
 - Islebay Drive
 - Manns Harbor Drive
 - Merritt Island Drive
 - Mirabay Blvd.
 - Pinckney Drive
 - Skimmer Drive
 - Tybee Island Drive
 - Wishing Arch Drive
 - Berm along SR 41
 - Club
 - Lee Te Kim Park
 - Playground
 - Tennis Courts
-
- Trimmed bushes and palm trees in multiple locations listed above.
 - Hand pulled weed and cleaned up plant beds in multiple locations listed above.
 - Picked up trash in multiple locations listed above.

MIRABAY LANDSCAPING STATUS REPORT

LEE TE KIM LANDSCAPE & LAWN CARE, INC.

127 16TH AVENUE SW

RUSKIN, FL 33570

(813) 645-1769 OFFICE

(813) 645-7314 FAX

DATE: MARCH 30, 2026

PROPOSAL SUBMITTED TO:

HARBOR BAY CDD

C/O RIZZETTA & COMPANY, INC.

3434 COLWELL AVE., SUITE 200

TAMPA, FL 33614

WORK PERFORMED – WEEK OF 3/23/2026

- Balibay Road
 - Golden Isle Drive
 - Ibis View Lane
 - Islebay Drive
 - Manns Harbor Drive
 - Mirabay Blvd.
 - Pinckney Drive
 - Skimmer Drive
 - Wishing Arch Drive
 - Berm along SR 41
 - Club
 - Lee Te Kim Park
 - Playground
 - Tennis Courts
-
- Trimmed bushes and palm trees in multiple locations listed above.
 - Hand pulled weed and cleaned up plant beds in multiple locations listed above.
 - Picked up trash in multiple locations listed above.

MIRABAY LANDSCAPING STATUS REPORT

LEE TE KIM LANDSCAPE & LAWN CARE, INC.

127 16TH AVENUE SW

RUSKIN, FL 33570

(813) 645-1769 OFFICE

(813) 645-7314 FAX

DATE: APRIL 6, 2026

PROPOSAL SUBMITTED TO:

HARBOR BAY CDD

C/O RIZZETTA & COMPANY, INC.

3434 COLWELL AVE., SUITE 200

TAMPA, FL 33614

WORK PERFORMED – WEEK OF 3/30/2026

- Admiral Point Drive
 - Balibay Road
 - Golden Isle Drive
 - Ibis View Lane
 - Islebay Drive
 - Manns Harbor Drive
 - Merritt Island Drive
 - Mirabay Blvd.
 - Pinckney Drive
 - Shore Crab Way
 - Skimmer Drive
 - Wishing Arch Drive
 - Berm along SR 41
 - Club
 - Lee Te Kim Park
 - Playground
 - Tennis Courts
-
- Trimmed bushes and palm trees in multiple locations listed above.
 - Hand pulled weed and cleaned up plant beds in multiple locations listed above.
 - Picked up trash in multiple locations listed above.

Tab 6

**HARBOR BAY CDD
(ROADWAY ANALYSIS)**

ROADWAYS	EXISTING ROADWAY CONDITIONS	ROADWAY LIFE EXPECTANCY
Water Fountain in front of clubhouse	Existing pavement cracks and low spots (ponding areas)	Mill & Resurface within 2 to 3 years
Admiral Point Dr.	Minor pavement cracks	Mill & Resurface within 4 to 5 years
Balibay Road	Existing low spots (ponding areas) and potholes throughout	Mill & Resurface within 2 to 3 years
Breakers Ln.	Minor pavement cracks	Mill & Resurface within 4 to 5 years
Brighton Shore Dr.	Some roadway cracks/potholes, and several cracked curbs	Mill & Resurface within 3 to 4 years
Coastal Scene Dr.	Minor pavement cracks	Mill & Resurface within 4 to 5 years
Covesound Way	Some median pavement cracks	Mill & Resurface within 3 to 4 years
Fishersound Ln.	Existing longitudinal pavement cracks throughout, and broken inlet	Mill & Resurface within 2 to 3 years
Golden Isles Dr.	Damaged inlet and exist. roadway pavement cracks throughout	Mill & Resurface within 3 to 4 years
Ibisview Ln.	Minor pavement cracks	Mill & Resurface within 4 to 5 years
Islebay Dr.	Existing low spot (ponding areas), pavement cracks, damaged inlets, and cracks at curbs throughout	Mill & Resurface within 3 to 4 years
Latitude Pl.	Existing roadway pavement cracks and rutting throughout	Mill & Resurface within 3 to 4 years
Loon Nest Ct.	Existing low spots (ponding areas), broken curb, and some pavement cracks	Mill & Resurface within 3 to 4 years
Manns Harbor Dr.	Existing cracks, rutting, and low spots (ponding areas) throughout	Mill & Resurface within 2 to 3 years
Merritt Island Dr.	Existing low spots (ponding areas), pot holes, and pavement cracks throughout	Mill & Resurface within 2 to 3 years
Mirabay Blvd.	Existing low spots (ponding areas) and pavement cracks throughout	Mill & Resurface within 2 to 3 years
Oceania Ct.	Minor pavement cracks	Mill & Resurface within 4 to 5 years
Point Harbor Ln.	Minor pavement cracks	Mill & Resurface within 4 to 5 years
Seagrass Pl.	Existing roadway pavement cracks, rutting, and pothole throughout	Mill & Resurface within 2 to 3 years
Sea Trout Pl.	Existing low spot (ponding areas), and pavement cracks throughout	Mill & Resurface within 3 to 4 years
Sea Turtle Pl.	Minor pavement cracks	Mill & Resurface within 4 to 5 years
Sela Cove Cir.	Minor pavement cracks	Mill & Resurface within 4 to 5 years
Shell Crest Ct.	Minor pavement cracks	Mill & Resurface within 4 to 5 years
Skimmer Dr.	Existing roadway pavement cracks, rutting, and pothole throughout	Mill & Resurface within 2 to 3 years
Summerside Ct.	Existing roadway pavement cracks (across the street and along the median)	Mill & Resurface within 2 to 3 years
Sunset Crest Ct.	Existing roadway pavement cracks	Mill & Resurface within 3 to 4 years
Tide Pl.	Minor pavement cracks	Mill & Resurface within 4 to 5 years
Tortoise Pl.	Minor pavement cracks	Mill & Resurface within 4 to 5 years
Tybee Island Dr.	Existing pavement cracks and broken curb	Mill & Resurface within 3 to 4 years
Windrose Pl.	Existing pavement cracks and rutting	Mill & Resurface within 3 to 4 years

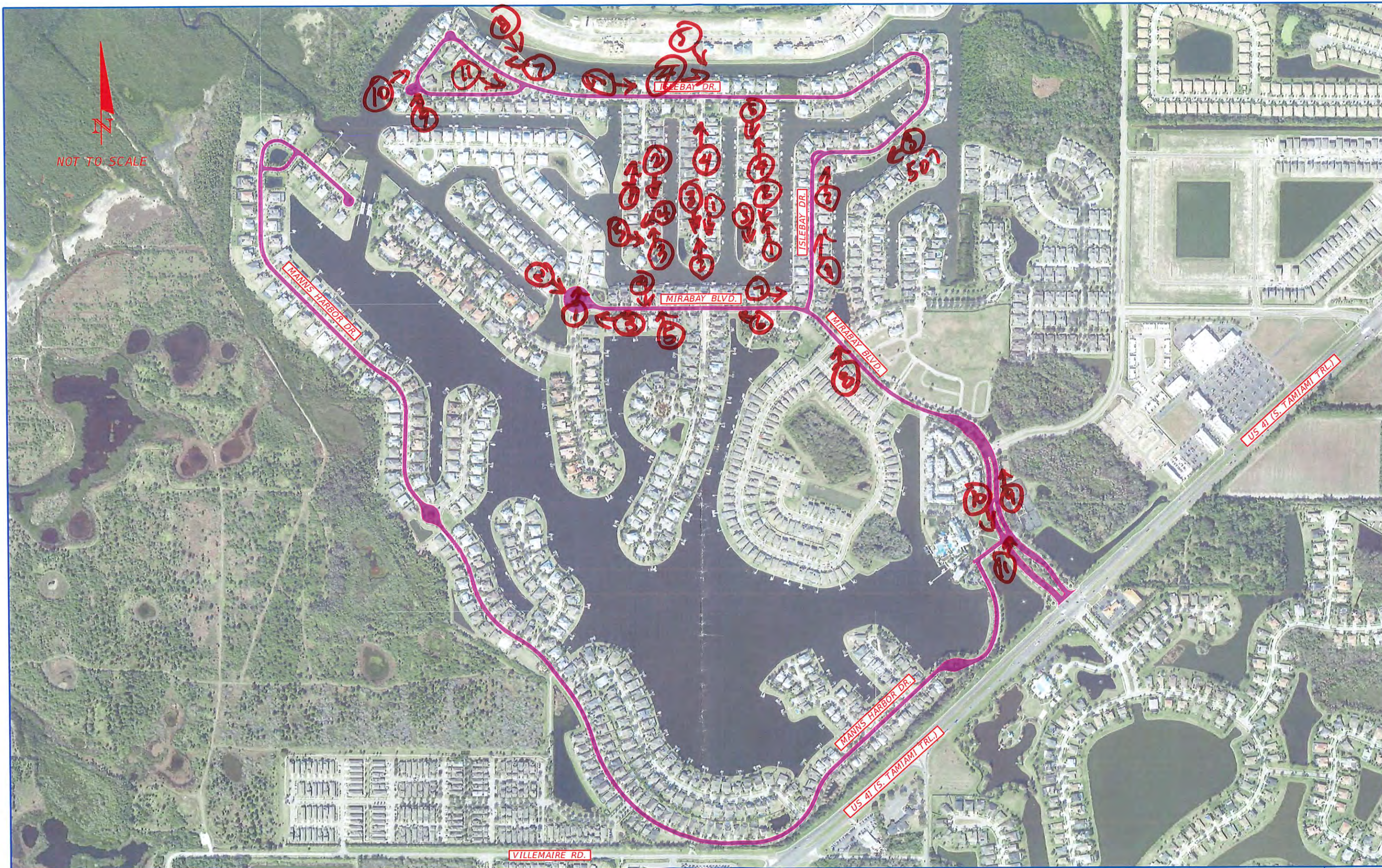

REVISIONS			
DATE	DESCRIPTION	DATE	DESCRIPTION

BRADLEY S. FORAN, P.E.
P.E. NO.: 52634
LIGHTHOUSE ENGINEERING INC.
701 ENTERPRISE ROAD EAST, SUITE 410
SAFETY HARBOR, FL 34695

HARBOR BAY COMMUNITY DEVELOPMENT DISTRICT		
ROAD NO.	COUNTY	FINANCIAL PROJECT ID
N/A	HILLSBOROUGH	N/A

MIRABAY STREETS
APOLLO BEACH, FLORIDA

SHEET
NO.

Islebay Drive:

- PIC 3 (Exist. cracks along curb at 507 Islebay Drive)
- PIC 9 (Exist. curb low spot/ponding between 831 and 833 Islebay Drive)
- PIC 10 (Exist. roadway cracks in front of 831 Islebay Drive)
- PIC 11 (Cracked inlet at 720 Islebay Drive)
- Exist. roadway cracks through Islebay Drive
- Recommendation: Mill & resurface Islebay Drive within 3-4 years

Mirabay Blvd:

- PIC 1 (Exist. curb low spot/ponding in front of 605 Mirabay Blvd.)
- PIC 3 (Exist. curb low spot/ponding southeast of 608 Mirabay Blvd.)
- PIC 4 (Cracked inlet at 510 Mirabay Blvd.)
- PIC 5 (Cracked inlet at 511 Mirabay Blvd.)
- PIC 11 (Cracked inlet at the entrance to Tennis Center)
- Exist. roadway cracks through Mirabay Blvd.
- Recommendation: Mill & resurface Mirabay Blvd. within 2-3 years

Sea Trout PL:

- PIC 1 (Exist. curb low spot/ponding at 5718 Sea Trout Pl.)
- PIC 2 (Exist. cracks along curb at 5713 Sea Trout Pl.)
- Exist. roadway cracks through Sea Trout Pl.
- Recommendation: Mill & resurface Sea Trout PL. within 3-4 years

Sea Turtle PL:

- PIC 5 (Exist. curb low spot/ponding at 5730 Sea Turtle Pl.)
- Exist. roadway cracks through Sea Turtle Pl.
- Recommendation: Mill & resurface Sea Turtle PL. within 4-5 years

Tortoise PL:

- PIC 4 (Exist. crack along curb at 5722 Tortoise Pl.)
- Exist. roadway cracks through Tortoise Pl.
- Recommendation: Mill & resurface Tortoise PL. within 4-5 years

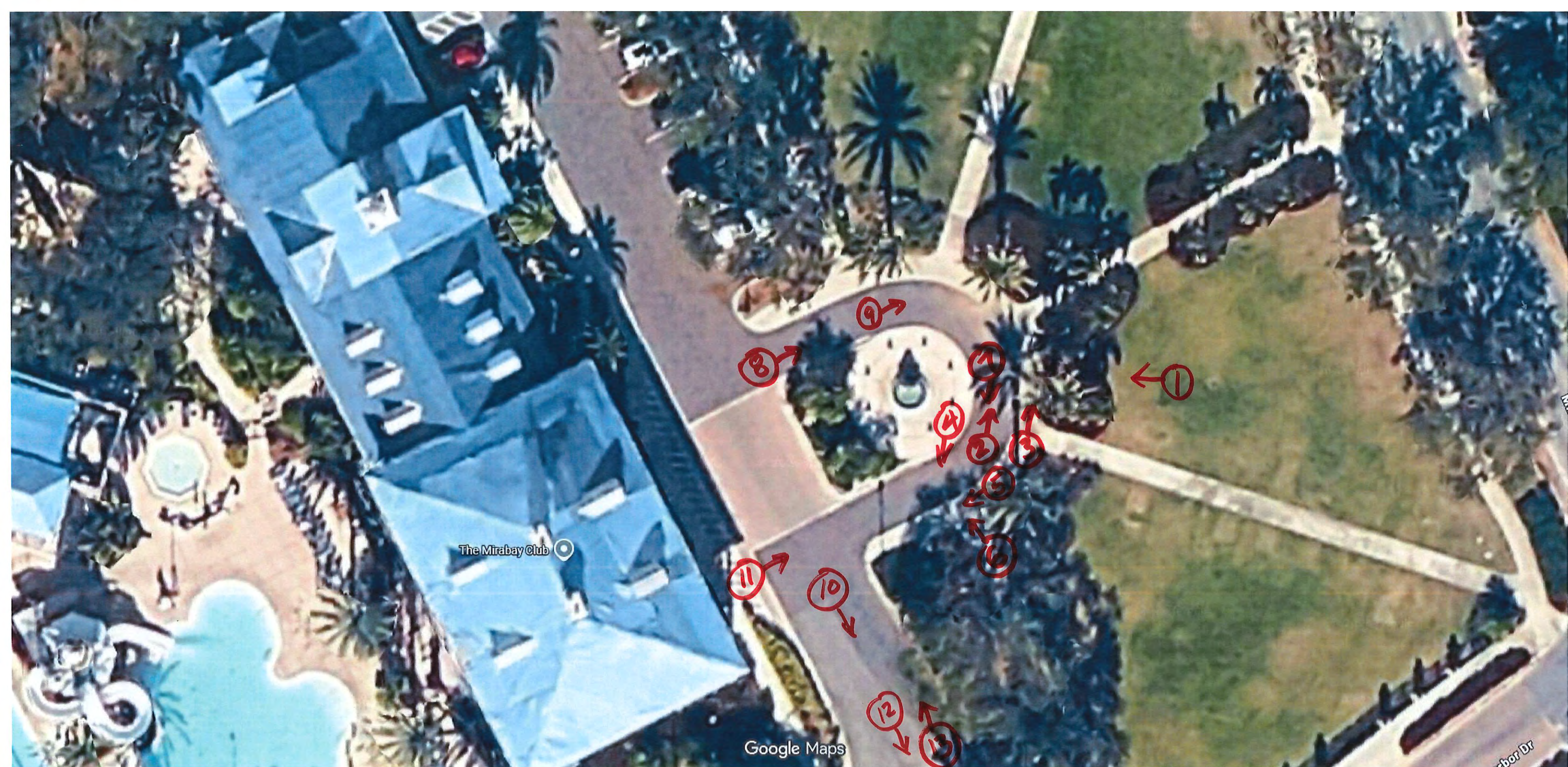

The Mirabay Club

Google Maps

bor Dr



REVISIONS			
DATE	DESCRIPTION	DATE	DESCRIPTION

BRADLEY S. FORAN, P.E.
P.E. NO.: 52634
LIGHTHOUSE ENGINEERING INC.
701 ENTERPRISE ROAD EAST, SUITE 410
SAFETY HARBOR, FL 34695

HARBOR BAY COMMUNITY DEVELOPMENT DISTRICT		
ROAD NO.	COUNTY	FINANCIAL PROJECT ID
N/A	HILLSBOROUGH	N/A

MIRABAY STREETS
APOLLO BEACH, FLORIDA

SHEET
NO.

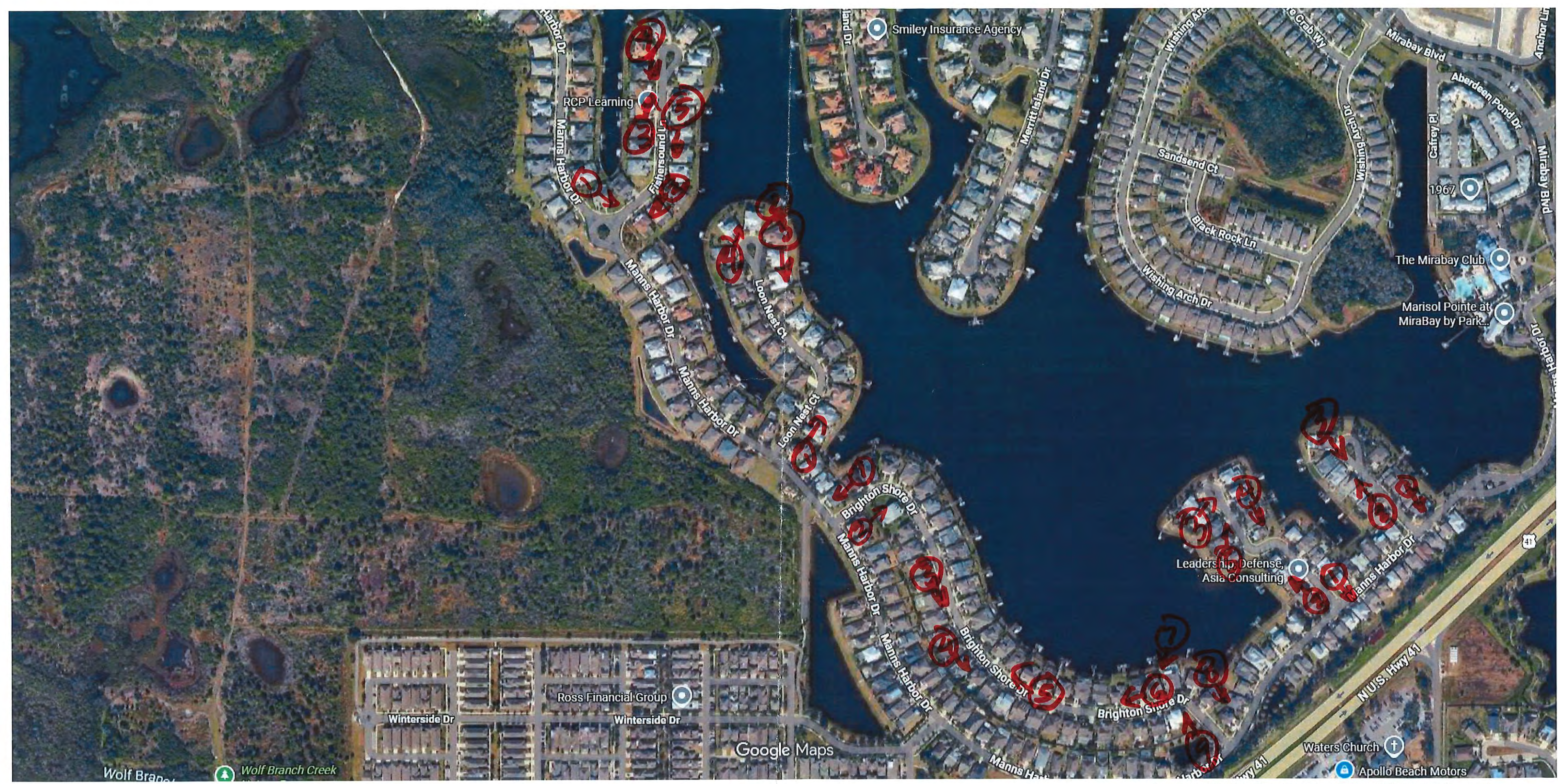

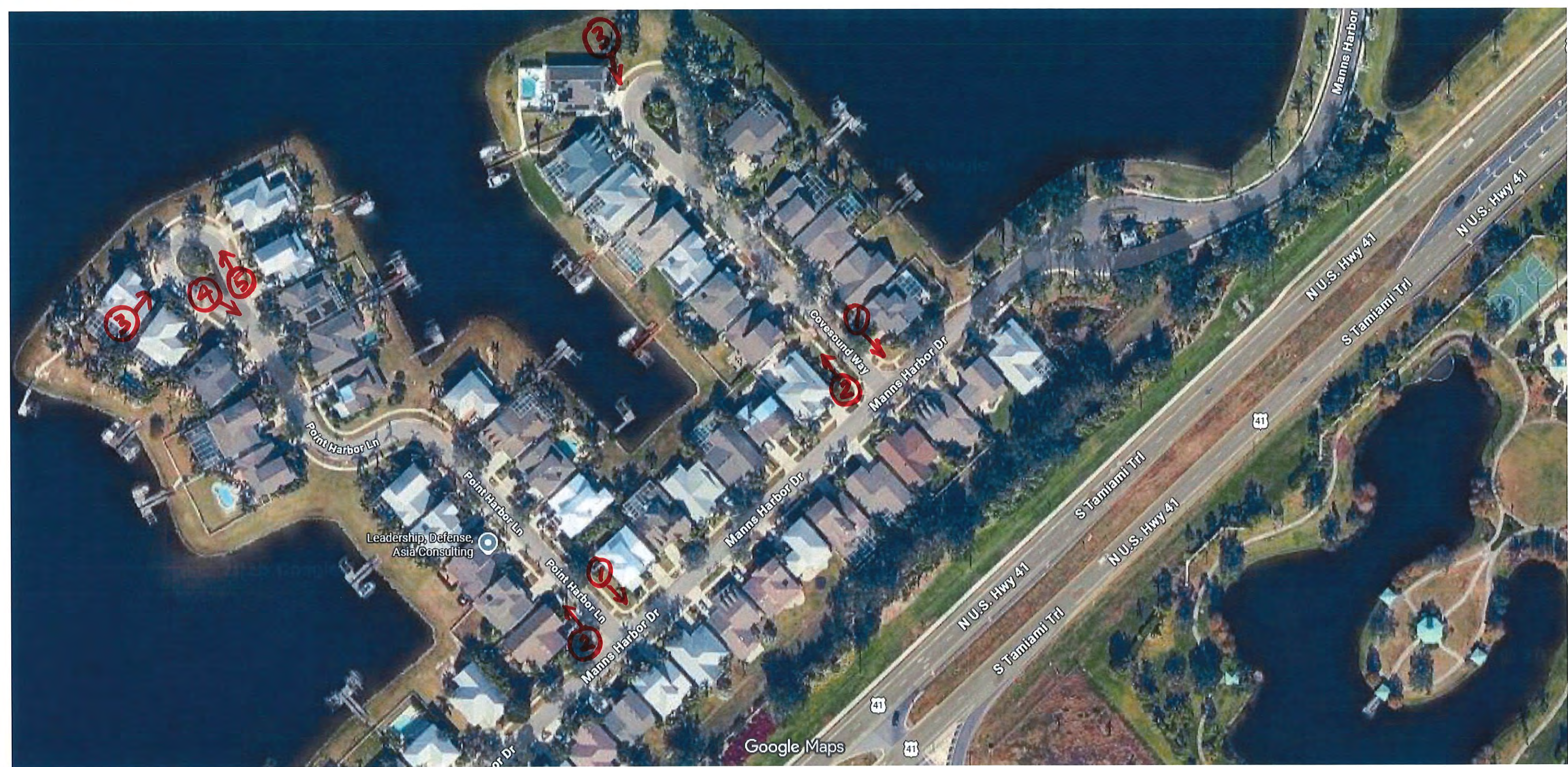

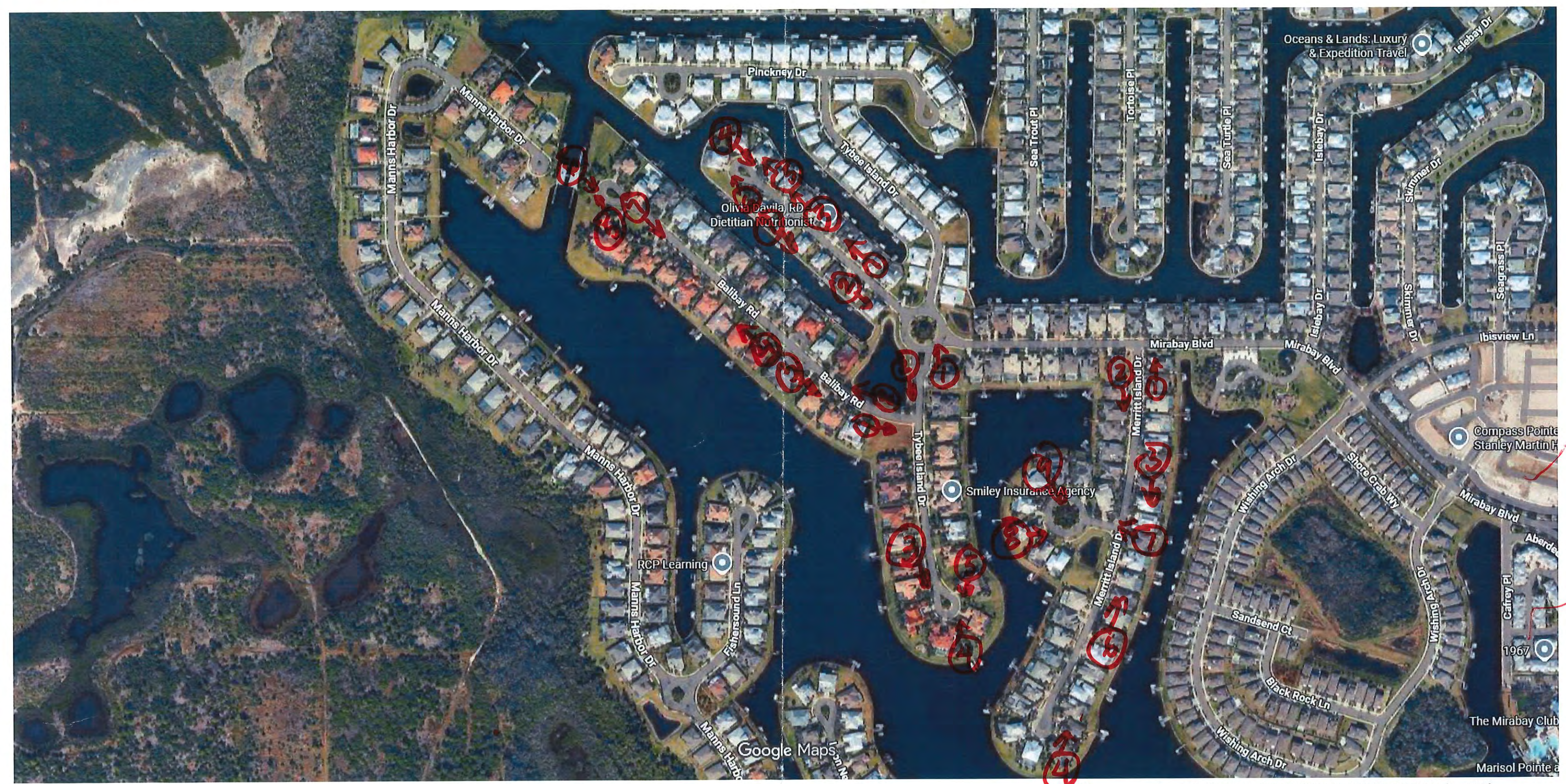

Handwritten red annotations: a circle containing the number 4, and a circle containing the number 5.

Balibay Road:

- PIC 3 (Exist. curb low spot/ponding across from 604 Balibay Road)
- PIC 4 (Exist. curb low spot/ponding across from 606 Balibay Road)
- PIC 5 (Exist. pothole west of 631 Balibay Road)
- Potholes and cracks throughout
- Recommendation: Mill & resurface Balibay Road within 2-3 years

Brighton Shore Drive:

- PIC 4 (Exist. curb cracked in front of 5250 Brighton Shore Drive)
- PIC 6 (Exist. curb cracked at 5239 Brighton Shore Drive)
- PIC 7 (Exist. pothole in front of 5240 Brighton Shore Drive)
- PIC 8 (Exist. curb cracked at 5233 Brighton Shore Drive)
- Minor cracks at roadway
- Recommendation: Mill & resurface Brighton Shore Drive within 3-4 years

Clubhouse:

- Exist. Pavement cracks and ponding throughout the water fountain area
- Exist. Pavement cracks throughout clubhouse
- Recommendation: Mill & resurface within 2-3 years

Covesound Way:

- Minor roadway cracks
- Recommendation: Mill & resurface Covesound Way within 3-4 years

Fishersound Ln.:

- Exist. roadway cracks through Fishersound Ln.
- Recommendation: Mill & resurface Fishersound Ln. within 2-3 years

Loon Nest Ct.:

- PIC 2 (Exist. curb cracked at 5327 Loon Nest Ct.)
- PIC 3 (Exist. curb low spot/ponding at 5327 Loon Nest Ct.)
- Recommendation: Mill & resurface Loon Nest Ct. within 3-4 years

Manns Harbor Drive

- PIC 2 (Exist. cracked inlets at Manns Harbor Dr. and Covesound Way)
- PIC 3 (Exist. curb low spot/ponding in front of 404 Manns Harbor Dr.)
- PIC 5 (Exist. curb low spot/ponding in front of 433 Manns Harbor Dr.)
- PIC 7 (Exist. curb low spot/ponding in front of 505 Manns Harbor Dr.)
- PIC 12 (Exist. curb low spot/ponding in front of playground – between 605 & 607 Manns Harbor Dr.)
- Roadway cracks and rutting throughout
- Recommendation: Mill & resurface Manns Harbor Dr. within 2-3 years

Merritt Island Drive:

- PIC 4 (Exist. curb low spot/ponding in front of 5403 Merritt Island Dr.)
- PIC 5 (Exist. curb low spot/ponding between 5405 & 5407 Merritt Island Dr.)
- PIC 8 (Exist. pothole in front of 509 509 Merritt Island Dr.)
- PIC 9 (Exist. pothole at 508 Merritt Island Dr.)
- Recommendation: Mill & resurface Merritt Island Drive within 2-3 years

Mirabay Blvd.:

- PIC 3 (Exist. curb low spot/ponding at 615 Mirabay Blvd.)
- PIC 4 (Exist. curb low spot/ponding at 625 Mirabay Blvd.)
- Recommendation: Mill & resurface Mirabay Blvd. within 2-3 years

Point Harbor Ln.:

- Minor roadway cracks
- Recommendation: Mill & resurface Point Harbor Ln. within 4-5 years

Tybee Island Drive:

- PIC 4 (Exist. curb cracked at 5403 Tybee Island Dr.)
- Exist. Roadway cracks throughout
- Recommendation: Mill & resurface Tybee Island Dr. within 3-4 years

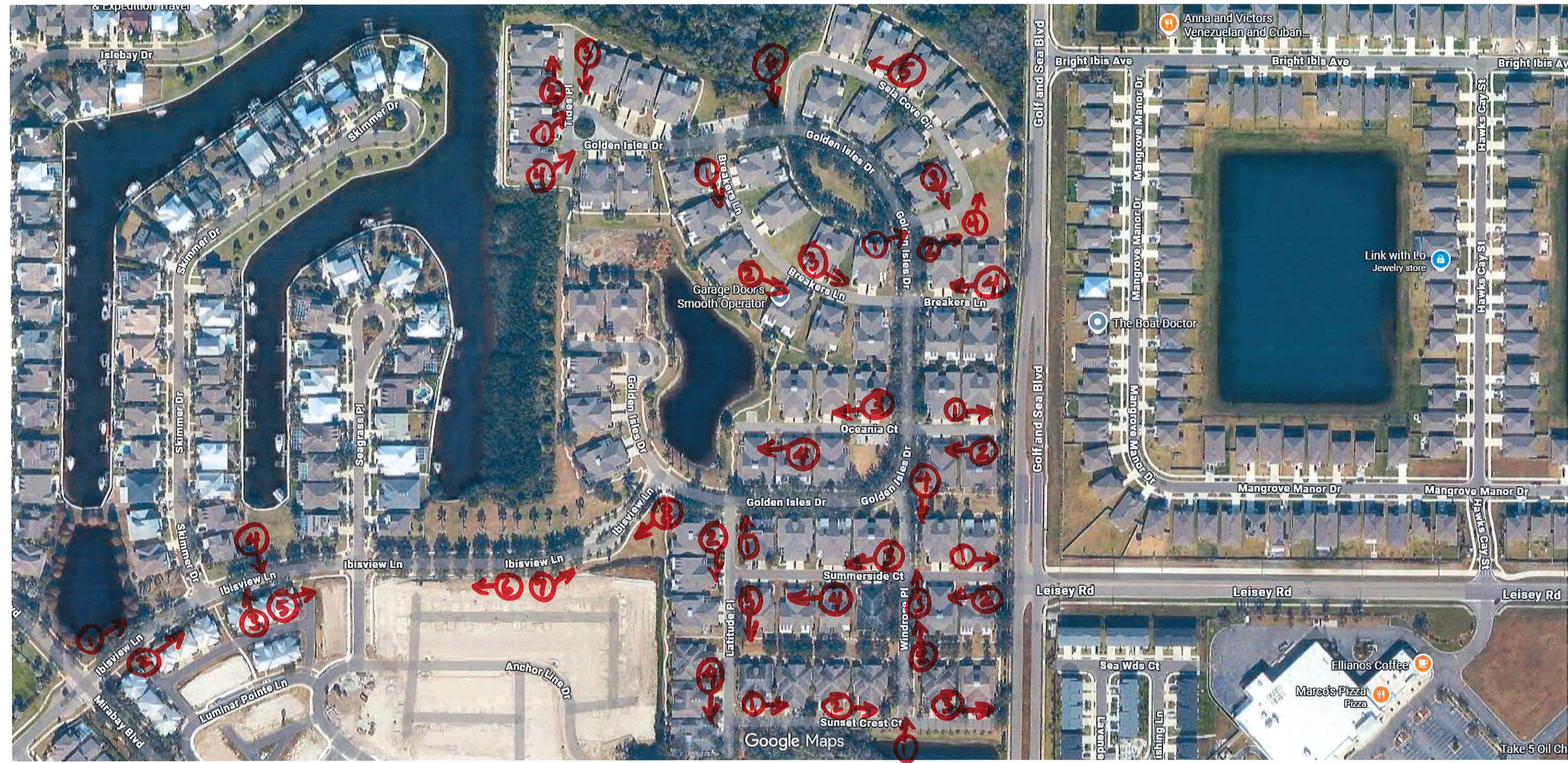



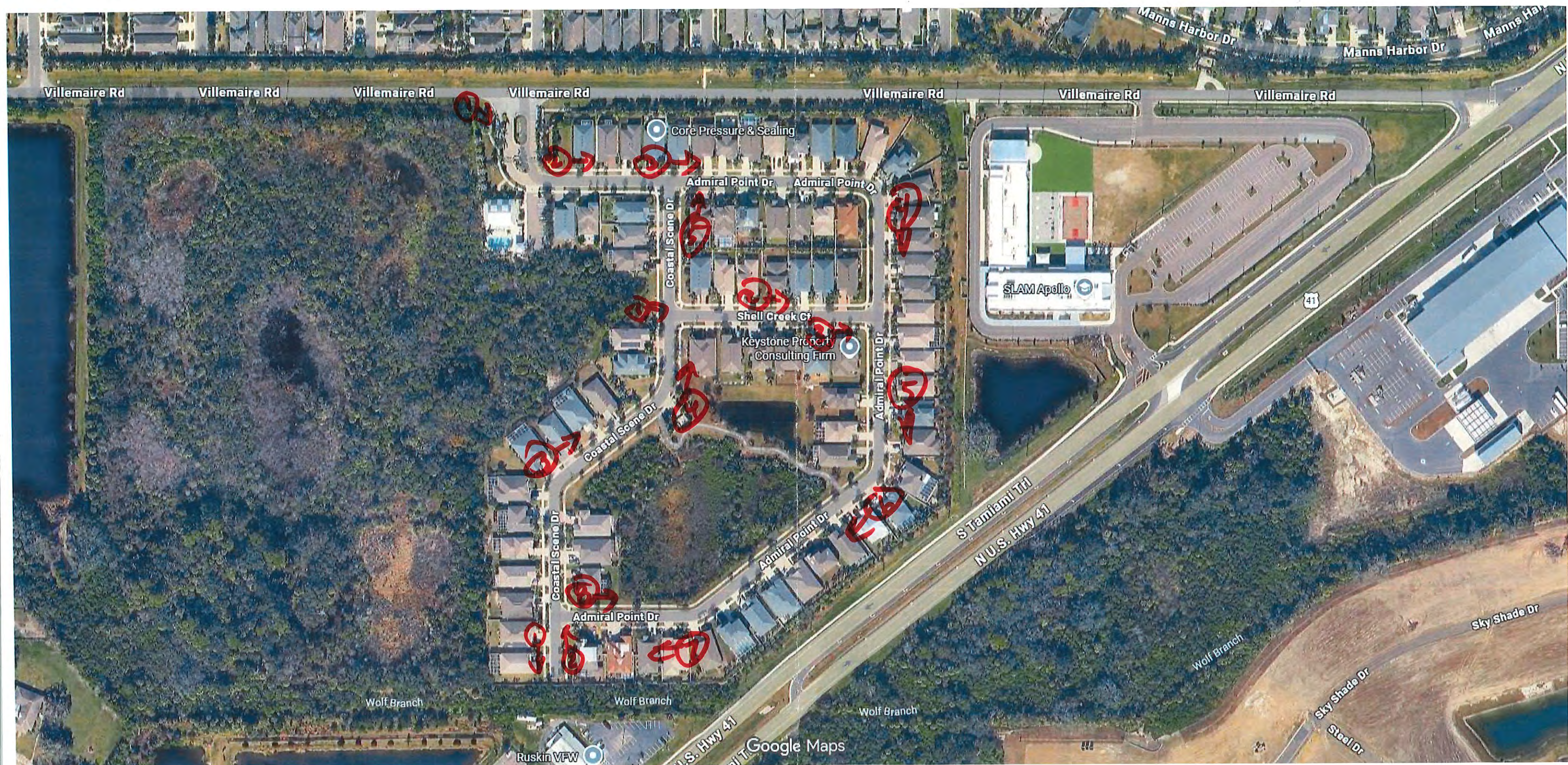

Admiral Point Dr.:

- Exist. roadway pavement in good condition with minor cracks throughout
- Recommendation: Mill & resurface Admiral Point Dr. within 4-5 years

Breakers Ln.:

- Exist. roadway pavement in good condition with minor cracks throughout
- Recommendation: Mill & resurface Breakers Ln. within 4-5 years

Coastal Scene Dr.:

- Exist. roadway pavement in good condition with minor cracks throughout
- Recommendation: Mill & resurface Coastal Scene Dr. within 4-5 years

Golden Isles Drive:

- PIC 9 (Exist. cracked inlet at Tides Pl. and Golden Isles Dr.)
- Exist. roadway pavement cracks throughout
- Recommendation: Mill & resurface Golden Isles Drive within 3-4 years

Ibisview Ln.:

- PIC 3 (Uneven curb located east of Skimmer Dr. and Ibisview Ln.)
- PIC 4 (Uneven curb located between Skimmer Dr. and Seagrass Pl.)
- PIC 6 (Exist. pothole located east of Seagrass Pl.)
- Exist. roadway pavement in good condition with minor cracks throughout
- Recommendation: Mill & resurface Ibisview Ln. within 4-5 years

Latitude Pl.:

- Exist. cracks and rutting along roadway pavement
- Recommendation: Mill & resurface Latitude Pl. within 3-4 years

Oceania Ct.:

- Exist. roadway pavement in good condition with minor cracks throughout
- Recommendation: Mill & resurface Oceania Ct. within 4-5 years

Seagrass Pl.:

- PICS 4 & 5 (Exist. pothole in front of 5613 Seagrass Pl.)
- Cracks, rutting, and potholes throughout roadway pavement
- Recommendation: Mill & resurface Seagrass Pl. within 2-3 years

Sela Cove Cir.:

- PIC 3 (Eroded pavement at parking area)
- Exist. roadway pavement in good condition with minor cracks throughout
- Recommendation: Mill & resurface Sela Cove Cir. within 4-5 years

Shell Crest Ct.:

- Exist. roadway pavement in good condition with minor cracks throughout
- Recommendation: Mill & resurface Shell Crest Ct. within 4-5 years

Skimmer Dr.:

- PIC 5 (Exist. pothole in front of 5624 Skimmer Dr.)
- Cracks, rutting, and potholes throughout roadway pavement
- Recommendation: Mill & resurface Skimmer Dr. within 2-3 years

Summerside Ct.:

- Exist. cracks along roadway pavement (across the street and along the median)
- Recommendation: Mill & resurface Summerside Ct. within 2-3 years

Sunset Crest Ct.:

- Exist. roadway pavement cracks throughout
- Recommendation: Mill & resurface Sunset Crest Ct. within 3-4 years

Tides Pl.:

- PIC 1 (Exist. cracked inlet at Tides Pl. and Golden Isles Dr.)
- Minor cracks throughout
- Recommendation: Mill & resurface Tides Pl. within 4-5 years

Windrose Pl.:

- PIC 4 (Exist. pavement rutting in front of 207 Windrose Pl.)
- Minor cracks throughout
- Recommendation: Mill & resurface Windrose Pl. within 3-4 years

Tab 7

Exhibit D

HARBOR BAY COMMUNITY DEVELOPMENT DISTRICT

REQUEST FOR REVIEW OF DOCK & BOAT LIFT PLANS

The undersigned owner seeks review by the Harbor Bay Community Development District of the following proposed improvement ("Improvements"): Dock OR Boat Lift OR Other (Specify here: 10568 Signet Drive, Apollo Beach FL 33572), at the following location:

Construct a 4' X 12' walkway over land to a 4' X 8' walkway out over water which turns left to a 4' X 30' dock with 20k boat lift

at the end of the dock as per the attached drawings.

Application Must Include

- A. Complete specifications for the dock, mechanical lift or applicable option.
- B. Drawing showing dock / lift layout, location and spacing of the outer lift piling and showing the required wrapping of the piling.
- C. Provide the contractor's name and attach a copy of their current license and proof of all necessary current and up-to-date insurance coverage.
- D. Recorded Dock Easement.

The CDD has adopted the MiraBay Master Dock Plan for Canal Lots ("Canal Lots Master Dock Plan") and the MiraBay Master Dock Plan for Lagoon Lots ("Lagoon Lots Master Dock Plan," and together with the Canal Lots Master Dock Plan, "Master Dock Plans"). The CDD's review of the plans for the Improvements is limited to a determination of whether the Improvements are consistent with the Master Dock Plans, the District's Southwest Florida Water Management District ERP No. 44-18838 (as amended from time to time), and the District's rules, including but not limited to the Rule Regarding District Waterways and Boating Facilities. The undersigned property owner and listed contractor hereby acknowledge and agree that the undersigned shall be solely responsible for determining whether the improvements, alterations and/or additions described herein comply with all applicable laws, rules and regulations, code and ordinances, including, without limitation, zoning ordinances, subdivision regulations and current building codes, and shall further be responsible for obtaining all necessary legal rights to conduct the work and install and operate the Improvements, including but not limited to applicable permits, real estate rights, licenses, easements, HOA approvals, etc. The CDD shall have no liability or obligation to determine whether such improvements, alterations and/or additions comply with any such laws, rules, regulations, easements, codes or ordinances and/or whether any such rights and/or approvals have been obtained. Only the Improvements described herein are allowed. No substitutions, changes and/or alterations will be allowed without the express written approval of the CDD.

Applications must be received by the CDD Manager patricia.comings-thibault@dpfg.com, 250 International Parkway, Suite 280, Lake Mary, Florida 32746, (321)263-0132. I agree to not begin work on improvements until I am notified in writing of the approval of the CDD. A fine may be imposed for any work started prior to approval.

I understand and agree as follows:

- a) I have reviewed the Master Dock Plans and the rules and policies of the CDD.
- b) My lot may be permitted to have a dock only if: 1) the dock is shown on the applicable dock plan, whether that is the Canal Lots Master Dock Plan or the Lagoon Lots Master Dock Plan, 2) the type of dock I propose is shown on the applicable dock plan, whether that is the Canal Lots Master Dock Plan or the Lagoon Lots Master Dock Plan, and 3) the dock is approved in writing.
- c) All Power Boats must be registered with the CDD, and the total number of registered Power Boats permitted in MiraBay is limited. Therefore, I may not be allowed to register more than one Power Boat if my dock is approved. Any registrations issued for Power Boats in excess of one Power Boat per lot are revocable at any time by the District in the District's sole discretion. The submission of this form to the District shall operate as the applicant's absolute consent to this potential revocation and waiver of any right to compensation from the District as a result of such revocation.

I further acknowledge and agree that in the event I, or any other owner or occupant of my lot violates any of these requirements, or violates any other rules or guidelines governing docks, lifts, accessories, and the docking of vessels, that I will be personally liable for all costs and expenses related to bringing these items into compliance, plus attorney fees and costs, including attorney fees and costs on appeal. I further acknowledge and agree that the CDD shall have all rights and remedies available at law or equity to enforce these requirements, rules, and guidelines, including but not limited to imposition of a reasonable fine pursuant to the CDD's rules and policies, as may be amended from time to time.

Property Owner Signature: <u>Ryan Grose</u>
Property Owner Name: <u>Ryan Grose</u> Date: <u>11/11/25</u>
Address: <u>1056 Signet Drive</u>
City / State / Zip: <u>Apollo Beach, FL 33572</u>
Phone Number: <u>8813-495-9605</u>

Contractor Signature: <u>Joseph P Valh</u>
Contractor Name: <u>Joseph P Valh</u> Date: <u>11/11/25</u>
Address: <u>905 Apollo Beach Blvd.</u>
City / State / Zip: <u>Apollo Beach, FL 33572</u>
Phone Number: <u>813-645-3625</u>

PRIVACY NOTICE: Under Florida's Public Records Law, Chapter 119, Florida Statutes, the information you submit on this form may become part of a public record. This means that, if a citizen makes a public records request, we may be required to disclose the information you submit to us. Under certain circumstances, we may only be required to disclose part of the information submitted to us. If you believe that your records may qualify for an exemption under Chapter 119, Florida Statutes, please notify the District Manager.

[CONTINUED ON NEXT PAGE]

RECOMMENDATION OF DISTRICT ENGINEER:

RECOMMEND APPROVAL, contingent on: _____

RECOMMEND DENIAL because _____

CDD BOARD APPROVAL:

APPROVED, contingent on: _____

NOTE: If this is for a Personal Water Craft lift located on the canal wall, the applicant must complete (1) the Canal Wall Connection Application; and (2) the License Agreement (Personal Watercraft Lift). Please see the attached Exhibit 1, incorporated by this reference, for the Canal Wall Application and License Agreement (Personal Watercraft Lift).

DENIED because _____

Exhibit 1

HARBOR BAY COMMUNITY DEVELOPMENT DISTRICT
250 International Parkway, Suite 280, Lake Mary, Florida 32746
ATTN: District Manager

CANAL WALL CONNECTION APPLICATION

The undersigned ("Owner") represent that they are the owners of record for the property described below ("Property"). The Owner desires to install and maintain a mechanical personal watercraft lift ("Lift") on the canal retaining wall (a/k/a seawall) adjacent to the Property owned and maintained by the Harbor Bay Community Development District ("CDD"), and are submitting this application for that approval.

Owner(s) Name(s) Ryan Grose
Lot Street Address Lot 87, 1056 Signet Drive
City, State and Zip Code Apollo Beach, FL 33572
Phone Number 813-495-9805
Lot Tax Folio Number 054191-2724

For Lifts being installed, please identify:
Contractor Name and License Number Joseph P Vath SCC131151418
Contractor Phone Number 813-645-3825
(Attach Certificate of Insurance from Contractor)
Expected Start Date: 12/1/25 Expected Completion Date: 12/1/26

This Canal Wall Connection Application, as well as the attached *License Agreement (Personal Watercraft Lift)*, is to be signed by all parties named as grantee or transferee in the most recent deed or other conveyance instrument recorded in the Official Records of Hillsborough County for the Property. Owner agrees to abide by the terms of the License Agreement (Personal Watercraft Lift).

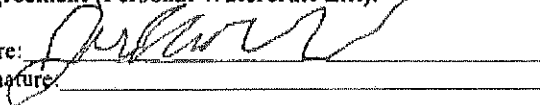
Owner Signature:  Date: 11/11/25
Co-Owner Signature: _____ Date: _____

Date: _____
Received by: _____
Harbor Bay Community Development District

For Office Use Only
APPROVED ___ DISAPPROVED ___
Explanation for Disapproval (if applicable): _____

PRIVACY NOTICE: Under Florida's Public Records Law, Chapter 119, Florida Statutes, the information you submit on this form may become part of a public record. This means that, if a citizen makes a public records request, we may be required to disclose the information you submit to us. Under certain circumstances, we may only be required to disclose part of the information submitted to us. If you believe that your records may qualify for an exemption under Chapter 119, Florida Statutes, please notify the District Manager.

ATTACHMENTS: LICENSE AGREEMENT & CDD SPECIFICATIONS (IF APPLICABLE)

This instrument was prepared by and upon recording should be returned to:

(This space reserved for Clerk)

District Counsel, Harbor Bay CDD
HOPPING GREEN & SAMS, P.A.
119 South Monroe Street, Suite 300
Tallahassee, Florida 32301

Parcel ID for Property: U-29-31-19-C7Y-000000-00087.0

**LICENSE AGREEMENT
(PERSONAL WATERCRAFT LIFT)**

This License Agreement (Personal Watercraft Lift) ("Agreement") is entered into as of this 11 day of November, 20 25, by and among:

The Harbor Bay Community Development District ("CDD"), a local unit of special purpose government created pursuant to Chapter 190, *Florida Statutes*; and

Ryan Grose and 1056 Signet Drive, Apollo Beach FL 33572
(together, "Owner"), the fee simple owners of the "Property" identified as:

Lot 87, Block 0, as per the plat ("Plat") identified as 1C7Y1 MARISOL POINTE and recorded in Plat Book 142, Pages 57 et seq., of the Public Records of Hillsborough County, Florida.

WITNESSETH:

WHEREAS, CDD is a special-purpose unit of local government that provides community infrastructure for the MiraBay community, including the community's master storm water system and, as part of that, a canal retaining wall, which is also referred to as a seawall ("Canal Wall"); and

WHEREAS, Owner owns the Property within MiraBay; and

WHEREAS, as part of the Plat, among other things, CDD holds certain drainage and other easements ("Easements") on the Property that allow CDD to install and maintain the Canal Wall and its related components; and

WHEREAS, Owner has requested authorization to install and maintain a mechanical personal watercraft lift ("Lift") on the Canal Wall immediately adjacent to the Property; and

WHEREAS, subject to the terms of this Agreement, CDD desires to grant Owner a license to install and maintain the Lift;

NOW, THEREFORE, in exchange for the mutual promises set forth herein, the receipt and sufficiency of which are hereby acknowledged, it is understood and agreed as follows:

1. **Recitals.** The recitals set forth above are acknowledged as true and correct and are incorporated herein by reference.

2. **License for Installation & Maintenance of Lift; Limitation.** Subject to the terms of this Agreement, CDD hereby grants Owner a non-exclusive, revocable license for the sole purpose of

installing and maintaining the Lift on the Canal Wall. Owner acknowledges that this Agreement authorizes only installation and maintenance of the Lift on the Canal Wall, and does not authorize any other impact or other alteration to the Canal Wall.

3. **Owner Responsibilities.** Owner has the following responsibilities:

- a. Owner shall be fully responsible for the installation and maintenance of the Lift, including all costs, and shall conduct such work in accordance with any CDD-approved specifications, as amended from time to time.
- b. Owner shall use a licensed and insured contractor to perform any installation and maintenance work pursuant to this Agreement.
- c. Owner shall ensure that the installation and maintenance of the Lift does not interfere with the CDD's rights in the Easements, and does not damage any property of CDD or any third party's property. Among other things, Owner shall be responsible for restoring any impact to the grass swale behind the Canal Wall, and shall further ensure that any installation and/or maintenance does not damage the Canal Wall or other related improvements, including, but not limited to, tie-back anchors, cap, and sheeting. In the event of any such damage, Owner shall immediately notify CDD, in which case CDD, at CDD's option, shall either direct Owner to repair the damage at Owner's expense, or shall conduct such repairs at Owner's expense.
- d. Owner shall be responsible for ensuring that the installation and maintenance of the Lift is conducted in compliance with all applicable laws, rules, and regulations, including, but not limited to, building codes and set back requirements.
- e. Owner shall keep CDD's Easements free from any materialmen's or mechanic's liens and claims or notices in respect to such liens and claims, which arise by reason of the Owner's exercise of rights under this Agreement, and Owner shall immediately discharge any such claim or lien.
- f. CDD, by entering into this Agreement, does not represent that CDD has authority to provide all necessary approvals for connection of the Lift. Instead, the Owner shall be responsible for obtaining any and all applicable permits and approvals relating to the work, including, but not limited to, any approvals (if any) of the MiraBay Homeowners Association, Inc. ("Association") and any other necessary legal interests and approvals.
- g. Upon completion of the installation, the Lift will be owned by the Owner. Owner shall be responsible for the maintenance and repair of any such Lift, and agrees to maintain the Lift in good condition and consistent with any CDD-approved specifications, as amended from time to time.

4. **Existing Rights.** Nothing herein is intended to limit or diminish in any way the CDD's existing rights in the Easements. The permission granted herein is given to Owner as an accommodation and is revocable at any time. Owner acknowledges the legal interest of the CDD in the Easements described above and agrees never to deny such interest or to interfere in any way with CDD's use. Owner will exercise the privilege granted herein at Owner's own risk, and agrees that Owner will never claim any damages against CDD for any injuries or damages suffered on account of the exercise of such privilege, regardless of the fault or negligence of the CDD. Owner further acknowledges that, without notice, and without recourse against the CDD, the CDD may revoke this Agreement and remove the Lift at Owner's expense, and that the CDD is not obligated to re-install the Lift as a result of the removal.

5. **Indemnification.** Owner agrees to indemnify, defend, and hold harmless the CDD, the Association, Hillsborough County, the Southwest Florida Water Management District, and any property management companies of the CDD and Association, as well as any officers, supervisors, staff, engineers, attorneys, agents and representatives of the foregoing, against all liability for damages and expenses resulting from, arising out of, or in any way connected with, this Agreement or the exercise of the privileges granted hereunder.

6. **Covenants Run with the Land.** This Agreement, and all rights and obligations contained herein, shall run with the land and shall be binding upon and inure to the benefit of the parties hereto and their respective heirs, successors and assigns, including, but without limitation, all subsequent owners of any portions of the property described herein and all persons claiming under them. Whenever the word "Owner" is used herein, it shall be deemed to mean the current owner of the Property and its successors and assigns. Upon the sale of the Property, Owner shall advise the subsequent owner of the terms and conditions of this Agreement. The CDD may at its option record this Agreement in the public records of Hillsborough County.

7. **Sovereign Immunity.** Nothing in this Agreement shall be deemed as a waiver of immunity or limits of liability of the CDD beyond any statutory limited waiver of immunity or limits of liability which may have been adopted by the Florida Legislature in Section 768.28, *Florida Statutes*, or other law, and nothing in this Agreement shall inure to the benefit of any third party for the purpose of allowing any claim which would otherwise be barred under the doctrine of sovereign immunity or by operation of law.

8. **Attorney's Fees & Costs.** The substantially prevailing party in any litigation to enforce the terms of this Agreement shall be entitled to reasonable attorney's fees, paralegal fees, expert witness fees, and costs.

9. **Counterparts.** This Agreement may be executed in counterparts. Any party hereto may join into this Agreement by executing any one counterpart. All counterparts when taken together shall constitute one agreement.

[SIGNATURES ON FOLLOWING PAGES]

[SIGNATURE PAGE TO LICENSE AGREEMENT (PERSONAL WATERCRAFT LIFT)]

Witnesses:

Owner

By: [Signature]

By: [Signature]

Robert L Adams III
Print Name

Ryan Ghis

By: [Signature]

Same address for both witnesses
905 Apollo Beach Blvd
Apollo Beach, FL 33572

Anjelica Carranza
Print Name

STATE OF FLORIDA)

COUNTY OF HILLSBOROUGH)

The foregoing instrument was acknowledged before me by means of physical presence or
[] online notarization this 19th day of JANUARY, 2020 by BRITTANY FULWIDER.
she is personally known to me or [] produced _____ as
identification.

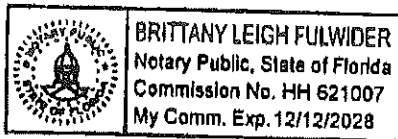

Brittany Fulwider
NOTARY PUBLIC

BRITTANY FULWIDER
(Print, Type or Stamp Commissioned Name of Notary Public)

[Signatures continue on following page]

IN WITNESS WHEREOF, the parties hereto have caused this License Agreement (Personal Watercraft Lift) to be executed the day and date first above written.

Witnesses:

By: [Signature]

Robert Adams III

Print Name

By: Anjelica Carranza

Anjelica Carranza

Print Name

Owner

By: Ryan Grose

Ryan Grose

Same address for both witnesses:
905 Apollo Beach Blvd
Apollo Beach, FL 33572

STATE OF FLORIDA)

COUNTY OF HILLSBOROUGH)

The foregoing instrument was acknowledged before me by means of physical presence or online notarization this 19th day of JANUARY, 2020 by BRITTANY FULWIDER. she is personally known to me or produced _____ as identification.



Brittany Fulwider
NOTARY PUBLIC

BRITTANY FULWIDER
(Print, Type or Stamp Commissioned Name of Notary Public)

[Signatures continue on following page]

HARBOR BAY COMMUNITY DEVELOPMENT DISTRICT
250 International Parkway, Suite 280, Lake Mary, Florida 32746
ATTN: District Manager

UTILITIES CONNECTION APPLICATION

The undersigned ("Owner") represent that they are the owners of record for the property described below ("Property"). The Owner desires to install (which shall include, without limitation, any reconnection work) and maintain power and water lines through the canal retaining wall (a/k/a seawall) adjacent to the Property owned and maintained by the Harbor Bay Community Development District ("CDD"), and are submitting this application for that approval.

Owner(s) Name(s) Ryan Grose
Lot Street Address Lot 87, 1056 Signet Drive
City, State and Zip Code Apollo Beach, FL 33572
Phone Number 813-495-9605
Lot Tax Folio Number 254191-2724

For power and water lines being installed (which shall include, without limitation, the reconnection of existing lines) please identify:
Contractor Name and License Number Robert Wade, EC13004328
Contractor Phone Number 813-770-8660
(Attach Certificate of Insurance from Contractor)
Expected Start Date: 12/1/25 Expected Completion Date: 12/1/26

This Utilities Connection Application, as well as the attached *License Agreement (Utilities Connection)*, is to be signed by all parties named as grantee or transferee in the most recent deed or other conveyance instrument recorded in the Official Records of Hillsborough County for this property. Owner agrees to abide by the terms of the License Agreement (*Utilities Connection*).

Owner Signature:  Date: 11/11/25
Co-Owner Signature: _____ Date: _____

Date: _____
Received by: _____
Harbor Bay Community Development District

For Office Use Only
APPROVED DISAPPROVED
Explanation for Disapproval (if applicable): _____

PRIVACY NOTICE: Under Florida's Public Records Law, Chapter 119, Florida Statutes, the information you submit on this form may become part of a public record. This means that, if a citizen makes a public records request, we may be required to disclose the information you submit to us. Under certain circumstances, we may only be required to disclose part of the information submitted to us. If you believe that your records may qualify for an exemption under Chapter 119, Florida Statutes, please notify the District Manager.

ATTACHMENTS: LICENSE AGREEMENT & CDD SPECIFICATIONS (IF APPLICABLE)

This instrument was prepared by and upon recording should be returned to:

(This space reserved for Clerk)

District Counsel, Harbor Bay CDD
HOPPING GREEN & SAMS PA
119 South Monroe Street, Suite 300
Tallahassee, Florida 32301

Parcel ID for Property: U-29-31-19-C7Y-000000-00087.0

**LICENSE AGREEMENT
(UTILITIES CONNECTION)**

This License Agreement (Utilities Connection) ("Agreement") is entered into as of this 11 day of November, 2025, by and among:

The Harbor Bay Community Development District ("CDD"), a local unit of special purpose government created pursuant to Chapter 190, *Florida Statutes*; and

Ryan Grose and 1056 Signet Drive, Apollo Beach FL 33572
(together, "Owner"), the fee simple owners of the "Property" identified as:

Lot 87, Block D, as per the plat ("Plat") identified as 1C7Y | MARISOL POINTE, and recorded in Plat Book 142, Pages 57 et seq., of the Public Records of Hillsborough County, Florida.

WITNESSETH:

WHEREAS, CDD is a special purpose unit of local government that provides community infrastructure for the MiraBay community, including the community's master storm water system and, as part of that, a canal retaining wall, which is also referred to as a seawall ("Canal Wall"); and

WHEREAS, Owner owns the Property within MiraBay; and

WHEREAS, as part of the Plat, among other things, CDD holds certain drainage and other easements ("Easements") on the Property that allow CDD to install and maintain the Canal Wall and its related components; and

WHEREAS, Owner has requested authorization to install (which shall include, without limitation, any reconnection work) and maintain power and water utility lines ("Utility Lines") through the Canal Wall and to Owner's dock; and

WHEREAS, in order to accommodate such requests, CDD has installed conduits in the Canal Wall for certain lots, and/or established a specification for the placement of Utility Lines through the Canal Wall for other lots (together, "Utility Pass-Throughs"); and

WHEREAS, subject to the terms of this Agreement, CDD desires to grant Owner a license to install and maintain the Utility Lines using the Utility Pass-Throughs;

NOW, THEREFORE, in exchange for the mutual promises set forth herein, the receipt and sufficiency of which are hereby acknowledged, it is understood and agreed as follows:

1. **Recitals.** The recitals set forth above are acknowledged as true and correct and are incorporated herein by reference.

2. **License for Installation & Maintenance of Utility Lines; Limitation.** Subject to the terms of this Agreement, CDD hereby grants Owner a non-exclusive, revocable license to use the CDD-authorized Utility Pass-Throughs for the sole purpose of installing and maintaining the Utility Lines through the Canal Wall and to the dock at the Property. Owner acknowledges that this Agreement authorizes only the connection and maintenance of power and water utilities through the Canal Wall, and does not authorize any other impact or other alteration to the Canal Wall.

3. **Owner Responsibilities.** Owner has the following responsibilities:

- a. Owner shall be fully responsible for the installation and maintenance of the Utility Lines, including all costs, and shall conduct such work in accordance with any CDD-approved specifications, as amended from time to time.
- b. Owner shall ensure that any connection of Utility Lines through the Canal Wall is done using the CDD-authorized Utility Pass-Throughs.
- c. Owner shall use a licensed and insured contractor to perform any installation and maintenance work pursuant to the Agreement.
- d. Owner shall ensure that the installation and maintenance of the Utility Lines does not interfere with the CDD's rights in the Easements, and does not damage any property of CDD or any third party's property. Among other things, Owner shall be responsible for restoring any impact to the grass swale behind the Canal Wall, and shall further ensure that any installation and/or maintenance does not damage the Canal Wall or other related improvements, including, but not limited to, tie-back anchors, cap, and sheeting. In the event of any such damage, Owner shall immediately notify CDD, in which case CDD, at CDD's option, shall either direct Owner to repair the damage at Owner's expense, or shall conduct such repairs at Owner's expense.
- e. Owner shall be responsible for ensuring that the installation and maintenance of the Utility Lines are conducted in compliance with all applicable laws, rules, and regulations, including, but not limited to, building codes and set back requirements.
- f. Owner shall keep CDD's Easements free from any materialmen's or mechanic's liens and claims or notices in respect to such liens and claims, which arise by reason of the Owner's exercise of rights under this Agreement, and Owner shall immediately discharge any such claim or lien.
- g. CDD, by entering into this Agreement, does not represent that CDD has authority to provide all necessary approvals for connection of the Utility Lines. Instead, the Owner shall be responsible for obtaining any and all applicable permits and approvals relating to the work, including, but not limited to, any approvals (if any) of the MiraBay Homeowners Association, Inc. ("Association") and any other necessary legal interests and approvals.
- h. Upon completion of the installation, the Utility Lines will be owned by the Owner. Owner shall be responsible for the maintenance and repair of any such Utility Lines, and agrees to maintain the Utility Lines in good condition and consistent with any CDD-approved specifications, as amended from time to time.

4. **Existing Rights.** Nothing herein is intended to limit or diminish in any way the CDD's existing rights in the Easements. The permission granted herein is given to Owner as an accommodation

and is revocable at any time. Owner acknowledges the legal interest of the CDD in the Easements described above and agrees never to deny such interest or to interfere in any way with CDD's use. Owner will exercise the privilege granted herein at Owner's own risk, and agrees that Owner will never claim any damages against CDD for any injuries or damages suffered on account of the exercise of such privilege, regardless of the fault or negligence of the CDD. Owner further acknowledges that, without notice, and without recourse against the CDD, the CDD may revoke this Agreement and remove the Utility Lines at Owner's expense, and that the CDD is not obligated to re-install the Utility Lines as a result of the removal.

5. **Indemnification.** Owner agrees to indemnify, defend, and hold harmless the CDD, the Association, Hillsborough County, the Southwest Florida Water Management District, and any property management companies of the CDD and Association, as well as any officers, supervisors, staff, agents and representatives of the foregoing, against all liability for damages and expenses resulting from, arising out of, or in any way connected with, this Agreement or the exercise of the privileges granted hereunder.

6. **Covenants Run with the Land.** This Agreement, and all rights and obligations contained herein, shall run with the land and shall be binding upon and inure to the benefit of the parties hereto and their respective heirs, successors and assigns, including, but without limitation, all subsequent owners of any portions of the property described herein and all persons claiming under them. Whenever the word "Owner" is used herein, it shall be deemed to mean the current owner of the Property and its successors and assigns. Upon the sale of the Property, Owner shall advise the subsequent owner of the terms and conditions of this Agreement. The CDD may at its option record this Agreement in the public records of Hillsborough County.

7. **Sovereign Immunity.** Nothing in this Agreement shall be deemed as a waiver of immunity or limits of liability of the CDD beyond any statutory limited waiver of immunity or limits of liability which may have been adopted by the Florida Legislature in Section 768.28, *Florida Statutes*, or other law, and nothing in this Agreement shall inure to the benefit of any third party for the purpose of allowing any claim which would otherwise be barred under the doctrine of sovereign immunity or by operation of law.

8. **Attorney's Fees & Costs.** The substantially prevailing party in any litigation to enforce the terms of this Agreement shall be entitled to reasonable attorney's fees, paralegal fees, expert witness fees, and costs.

9. **Counterparts.** This Agreement may be executed in counterparts. Any party hereto may join into this Agreement by executing any one counterpart. All counterparts when taken together shall constitute one agreement.

[SIGNATURES ON FOLLOWING PAGES]

IN WITNESS WHEREOF, the parties hereto have caused this License Agreement (Utilities Connection) to be executed the day and date first above written.

Witnesses:

By: [Signature]

Robert L Adams III

Print Name

By: [Signature]

Anjelica Carranza

Print Name

Owner

By: [Signature]

Ryan Grose

Same address for both witnesses
905 Apollo Beach Blvd
Apollo Beach, FL 33572

STATE OF FLORIDA)

COUNTY OF HILLSBOROUGH)

The foregoing instrument was acknowledged before me by means of physical presence or online notarization this 19th day of JANUARY, 2024 by BRITANY FULWIDER. she he is personally known to me or I produced _____ as identification.



[Signature]
NOTARY PUBLIC

BRITANY FULWIDER
(Print, Type or Stamp Commissioned Name of Notary Public)

[Signatures continue on following page]

[SIGNATURE PAGE TO LICENSE AGREEMENT (UTILITIES CONNECTION)]

Witnesses:

By: [Signature]
Robert L Adams III

Print Name

Owner

By: [Signature]
Ryan Brock

By: Anjelica Carranza
Anjelica Carranza

Print Name

Same address as both witnesses
905 Apollo Beach Blvd
Apollo Beach, FL 33572

STATE OF FLORIDA)

COUNTY OF HILLSBOROUGH)

The foregoing instrument was acknowledged before me by means of physical presence or online notarization this 19th day of JANUARY, 2020, by BRITTANY FULWIDER. He she is personally known to me or produced _____ as identification



Brittany Fulwider
NOTARY PUBLIC

BRITTANY FULWIDER
(Print, Type or Stamp Commissioned Name of Notary Public)

[Signatures continue on following page]

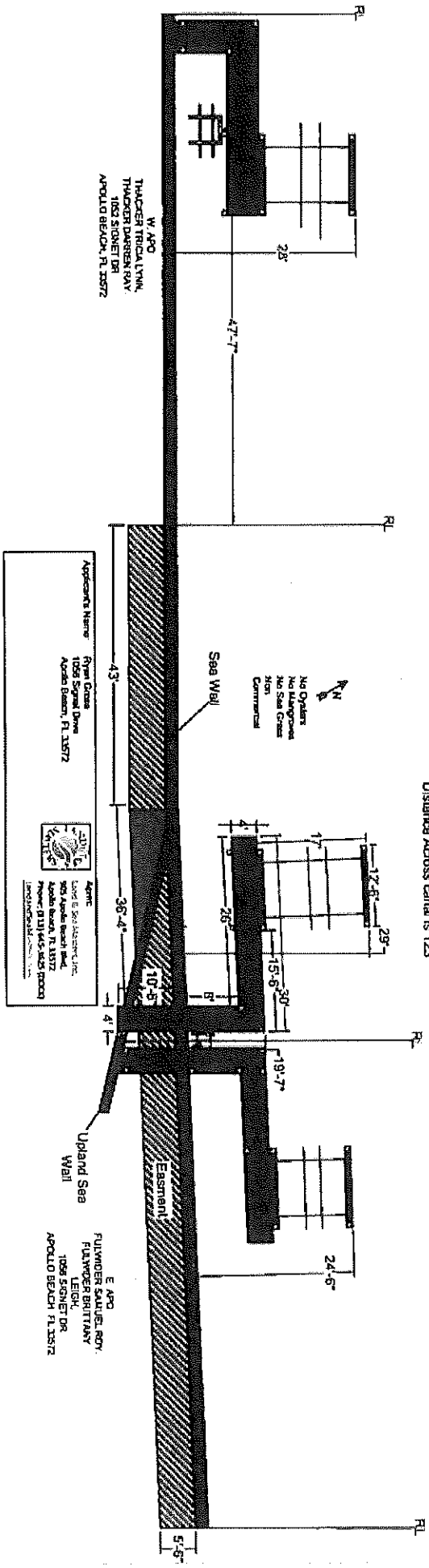

Distance Across canal is 123'

W. APO
 THACKER TRICALYNIK,
 THACKER DARRIN RAY
 1055 SIGNAL DR
 APOLLO BEACH, FL 32572

Appointee Name	From Office	Agency
1055 Signal Drive	1055 Signal Drive	State of Florida
Apollon Beach, FL 32572	Apollon Beach, FL 32572	Apollon Beach, FL 32572

 State of Florida
 Department of Transportation
 1055 Signal Drive
 Apollon Beach, FL 32572
 Phone: (904) 445-4625 (TDD)

E. APO
 FLYNNER SAULTE, ROY,
 FLYNNER BRITTANY
 LEIGH,
 1055 SIGNAL DR
 APOLLO BEACH FL 32572

Distance Across canal is 123'

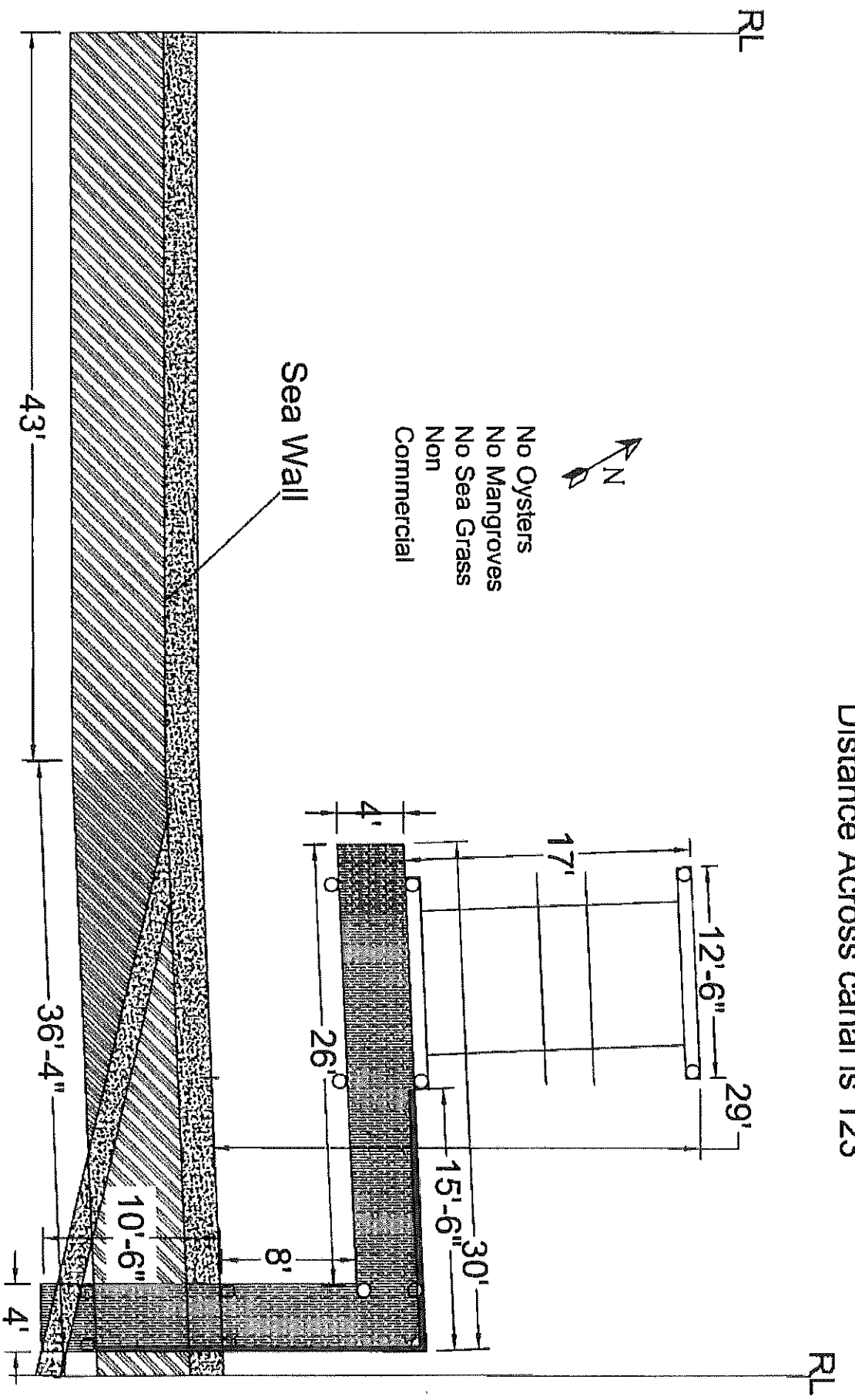

- No Oysters
- No Mangroves
- No Sea Grass
- Non Commercial



Applicant's Name:

Ryan Grose
1056 Signet Drive
Apollo Beach, FL 33572



Agent:

Land & Sea Masters, Inc.
905 Apollo Beach Blvd,
Apollo Beach, FL 33572
Phone: (813) 645-3625 (DOCK)
LandandSeaMasters.com

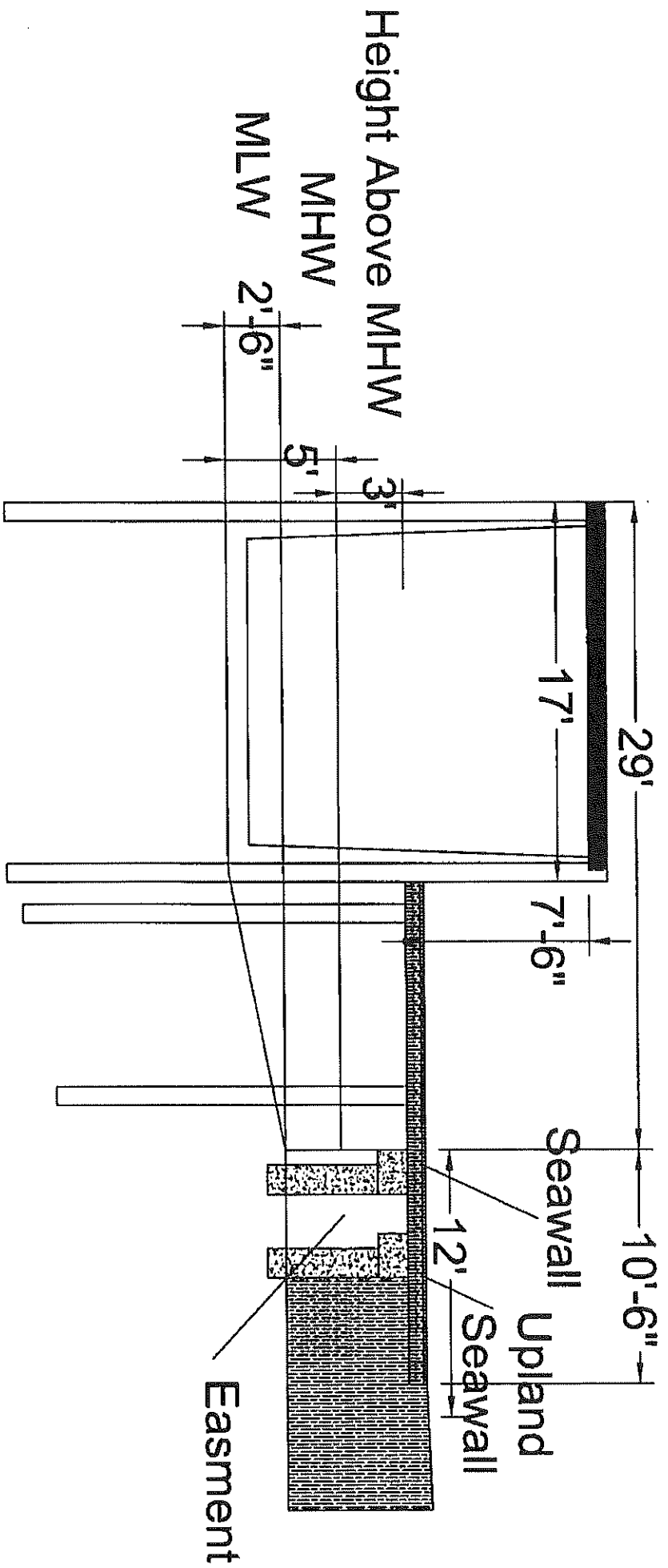

Height Above MHW

MHW

MLW 2'-6"

3'

5'

29'

17'

7'-6"

10'-6"

Seawall

Upland

Seawall

12'

Easement

Applicant's Name: Ryan Grose

1056 Signet Drive

Apollo Beach, FL 33572

Engineering:



Agent:

Land & Sea Masters, Inc.

905 Apollo Beach Blvd,

Apollo Beach, FL 33572

Phone: (813) 645-3625 (DOCK)

LandandSeaMasters.com

Consideration: \$3,500.00
Documentary Stamps Paid: \$24.50

Prepared by and when
Recorded return to:

Shutts & Bowen LLP
Tirso M. Carreja, Jr., Esq.
4301 W. Boy Scout Boulevard
Suite 300
Tampa, Florida 33607

**DECLARATION OF DOCK EASEMENT, COVENANTS
AND RESTRICTIONS FOR
LOT 87, MARISOL POINTE
PER PLAT BOOK 142, PAGE 57, OF THE PUBLIC RECORDS OF
HILLSBOROUGH COUNTY, FLORIDA**

THIS DECLARATION OF DOCK EASEMENT, COVENANTS AND RESTRICTIONS (the “**Dock Easement Declaration**”) is made, executed, granted, imposed and declared this 21 day of February, 2025, by **PARK SQUARE ENTERPRISES, LLC**, a Delaware limited liability company (“**Park Square**”) to and in favor of the Owner (as that term is defined below) of Lot 87, MARISOL POINTE, according to the plat thereof (the “**Plat**”) recorded in Plat Book 142, Page 57, of the Public Records of Hillsborough County, Florida (“**Benefitted Lot**”).

RECITALS

A. The term “**Owner**” shall mean and refer to the fee simple record owner of the Benefitted Lot. The term “**Dock Structure**” shall refer to a dock consisting of a deck/walking surface on pilings and/or floatation devices or materials now or hereafter constructed in the Tract (hereinafter defined), and which is located adjacent to the rear boundary line of the Benefitted Lot, and may include boat lift pilings as described in Article I below, all subject to approval as provided in Article III below.

B. Park Square is the fee simple record owner of TRACT “C” shown and described on the Plat (the “**Tract**”).

C. The Tract contains a canal (the canal sometimes being referred to herein as the “**Waterbody**”), which is adjacent to, and shares a common boundary line with, the Benefitted Lot. Park Square wishes to grant to the Owner of the Benefitted Lot certain rights to own, maintain and enjoy a Dock Structure located in the Waterbody, subject to the terms and conditions set forth herein.

**ARTICLE I
EASEMENT FOR DOCK STRUCTURE**

For \$10.00 and other valuable consideration, the receipt of which is hereby acknowledged, Park Square does hereby give, grant and convey to the Owner of the Benefitted Lot a perpetual non-exclusive easement (the “**Dock Easement**”) to own, maintain, repair and replace, at Owner’s sole cost and expense, a Dock Structure adjacent to the Benefitted Lot. The Dock Easement granted by this Article is on and over that portion of the Tract lying immediately under the Dock Structure at the location where the Dock Structure is approved as provided in Article III below, and includes the right to own, maintain, repair and replace pilings

on the bottom of the Tract at the locations where the pilings supporting the Dock Structure and/or boat lift are approved pursuant to Article III below (the “**Dock Easement Area**”). The Dock Easement includes the right, and the Owner of the Benefitted Lot is hereby granted, a perpetual non-exclusive easement to install boat lift pilings (i.e., inner and outer boat lift pilings, which are designed as the supports of a boat lift) on the bottom of the Tract, subject to approval of any such boat lift pilings as described in Article III below.

After the Dock Structure is approved pursuant to Article III below, Park Square shall have the right (but not the obligation) to record in the public records a notice (a “**Notice of Dock Easement Area**”) describing (by metes and bounds description or by means of a sketch) the Dock Easement Area, in order to provide future purchasers of the Benefitted Lot record notice of the Dock Easement Area covered by this Dock Easement. No party other than Park Square shall be required to join in, or consent to, the Notice of Dock Easement Area in order to make it effective and binding on the Owner or any mortgagee of the Benefitted Lot. The Dock Easement granted by this Article I shall be confined to the Dock Easement Area.

ARTICLE II **EASEMENT FOR OTHER DOCK ENCROACHMENTS**

Some portions of the Dock Structure may inadvertently encroach slightly into a “dock easement area” serving an adjoining Lot, and the “dock structure” constructed on an adjoining Lot may encroach slightly into the Dock Easement Area serving the Benefitted Lot. If such an encroachment exists as the result of the original construction of a “dock structure” or the Dock Structure as approved, as applicable, any such encroaching structure shall also automatically have and is hereby granted an easement for such encroachment so long as it exists. In the event any encroaching dock structure or the Dock Structure must be replaced in the future, the replacement dock structure or Dock Structure, as applicable, shall have an easement for an encroachment of the same degree and size as the original encroaching structure, subject to approval of any replacement structure as required by Article III below.

ARTICLE III **APPROVAL OF DOCK STRUCTURE**

This Dock Easement Declaration grants only easement rights in the Tract owned by Park Square, as expressly provided herein. Nothing in this Dock Easement Declaration shall be deemed an authorization to construct, or the approval of, any Dock Structure, associated pilings, any boat, other watercraft, any water fixtures, or any other improvement, fixtures, or property associated with the Dock Structure, or otherwise, within the Waterbody, all of which are subject to the approval of Harbor Bay Community Development District (its successors or assigns, the “**CDD**”) in accordance with the MiraBay Master Dock Plan, the Harbor Bay Community Development District Rule Regarding District Waterways and Boating Facilities (as amended, restated, and/or supplemented from time to time), and any other rules, restrictions, requirements or guidelines promulgated by the CDD, from time to time, related to improvements and property within the Waterbody (collectively, the “**Dock Rules**”). Owner should obtain the Dock Rules from the CDD, and Owner must obtain the CDD’s approval prior to constructing any improvement or maintaining any property within the Waterbody. Park Square makes no representation or warranty that the CDD will grant any approvals to Owner.

ARTICLE IV **COVENANTS AND RESTRICTIONS**

1. The Dock Rules may include, without limitation, rules regarding approval and registration of boats and other watercraft, the total number of watercraft in MiraBay, the maximum length of watercraft that may be docked in MiraBay (all of which may differ between the Benefitted Lot and any other lot in MiraBay), and rules regarding the maintenance of dock structures, watercrafts, and other improvements and property

within the Waterbody. The existence of any dock, watercraft, property or fixture, or the condition thereof, shall not be deemed a representation or warranty that any such dock, watercraft, property, fixture, or condition will be approved or permitted with respect to the Benefitted Lot.

2. The Owner of the Benefitted Lot shall repair and maintain the Dock Structure in good condition and repair, at Owner's sole cost and expense, and if necessary shall replace the Dock Structure from time to time, all subject to the Dock Rules. If Owner fails to maintain, repair or replace the Dock Structure as required by this section, then Park Square shall have the right, but not the obligation, to perform such maintenance, repair or replacement at the Owner's sole cost and expense, and Owner shall reimburse such amounts to Park Square within ten (10) days of written demand to Owner. If Owner fails to reimburse Park Square as required by this section within such 10-day period, then the amount due by Owner to Park Square shall accrue interest at the rate of ten percent (10%) per annum from the date due until actually paid, and Park Square shall have the right to record a lien in the Public Records against title to the Benefitted Lot and/or Owner's interest in the Dock Easement and Dock Easement Area, to secure any amount owed by Owner to Park Square in accordance with this section, and to foreclose on such lien in accordance with Florida law.

3. The Owner of the Benefitted Lot, by joining herein or by taking title to the Benefitted Lot, as applicable, agrees to and shall indemnify and hold harmless Park Square, the CDD, the MiraBay Homeowners Association, Inc., Park Square Enterprises, LLC d/b/a Park Square Homes, and their respective officers, directors, partners, members, shareholders, employees, agents and affiliates of every tier, and each affiliate's officers, directors, agents and employees (all of the foregoing collectively, the "Indemnified Parties"), from and against any claims, losses or liabilities arising out of or related to the easement rights granted herein or construction or use of any Dock Structure, watercraft, fixtures, or other property or improvements, by any party. The Owner's obligation to indemnify the Indemnified Parties shall include, without limitation: (a) claims arising out of accidents occurring on, or as a result of a person falling or jumping from, a Dock Structure, watercraft, fixtures, or other property or improvements; (b) claims arising out of the utilization of the Dock Structure or other improvements to tie up or hoist a watercraft; (c) claims arising out of watercraft or persons running into the Dock Structure, fixtures, or other property or improvements; (d) claims arising out of Owner's, its family, guests, contractors and subcontractors, and employees dumping of any debris in the Waterbody; and (e) Owner's, its guests' or invitees' non-compliance with the Dock Rules, or failure to obtain approval of any Dock Structure, watercraft, fixtures, or other property or improvements as required by Article III above.

ARTICLE V MISCELLANEOUS

Article and paragraph captions are for reference only, and shall not be considered in interpreting the contents of any Article or paragraph, nor shall they be deemed to limit the scope of any Article or paragraph. In any legal or arbitration proceeding arising out of or related to this Dock Easement Declaration, the prevailing party shall be entitled to recover its attorneys' fees and costs incurred in connection with such proceeding. This Dock Easement Declaration shall constitute covenants and restrictions running with the land, both benefitting and burdening title to the Benefitted Lot and the portion of the Tract constituting the Dock Easement Area. This Dock Easement Declaration may not be amended except in writing signed by the fee simple owner of the Benefitted Lot and the fee simple owner of the Tract.

(REMAINDER OF PAGE INTENTIONALLY LEFT BLANK)

(SIGNATURES PAGE TO FOLLOW)

IN WITNESS WHEREOF, the Park Square has executed this Dock Easement Declaration.

Signed, sealed and delivered
in the presence of:

PARK SQUARE ENTERPRISES, LLC,
a Delaware limited liability company

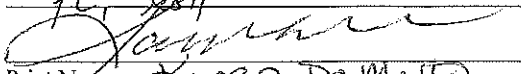

 Print Name: ROCHELLE SEQUINO
 Address: 5200 VINELAND RD, ORLANDO
FL 32811

 Print Name: Karen DeMello
 Address: 5750 MASER BLVD #110
Orlando FL 32819

By: 
 Name: Suresh Gupta
 Title: Manager
 Date: 2/21/2025
 Address: 5200 Vineland Road, Ste. 200
Orlando, FL 32811

STATE OF FLORIDA)
 ORANGE)
 COUNTY OF HILLSBOROUGH)

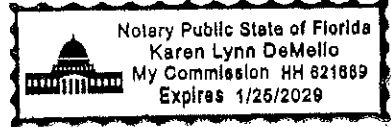
I, Karen Lynn DeMello, a Notary Public for said County and State, do hereby certify that Suresh Gupta appeared before me this day by means of physical presence or online notarization and is either personally known to me or produced as identification and acknowledged that s/he is the MANAGER of PARK SQUARE ENTERPRISES, LLC, a Delaware limited liability company, and that s/he, as Manager, being authorized to do so, executed this Dock Easement Declaration on behalf of PARK SQUARE ENTERPRISES, LLC, a Delaware limited liability company.



(AFFIX NOTARY SEAL)

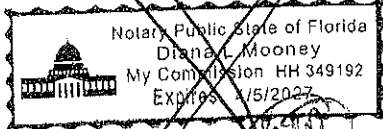

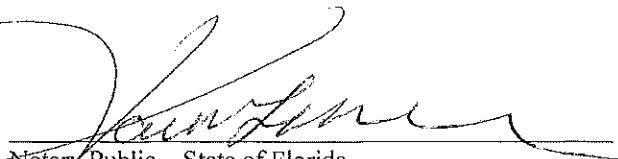
 Notary Public - State of Florida
 Print Name: Karen L. DeMello
 My Commission Expires: _____

JOINDER AND CONSENT OF OWNER(S)

The undersigned Owner(s) hereby joins in and consents to the Dock Easement, Covenants and Restrictions to which this joinder and consent is attached.

OWNER:

[Signature]
Ryan Alexander Grose
Date: 2/21/2025

OWNER:

[Signature]
Carmina Leigh Grose
Date: 2/21/2025
Address: 1056 Signet Drive
Apollo Beach, FL 33572

WITNESSES:

[Signature]
Print Name: AMBER MILLS
Address: 10542 US HWY 41 N #101
APOLLO BEACH, FL 33572

[Signature]
Print Name: Diana L Mooney
Address: 2309 Cherry Ridge Ln
Brandon, FL 33511

WITNESSES:

[Signature]
Print Name: AMBER MILLS
Address: 10542 US HWY 41 N #101
APOLLO BEACH, FL 33572

[Signature]
Print Name: Diana L Mooney
Address: 2309 Cherry Ridge Ln
Brandon, FL 33511

STATE OF FLORIDA
COUNTY OF Hillsborough

I, Diana L Mooney, a Notary Public for said County and State, do hereby certify that Ryan Alexander Grose appeared before me this day by means of physical presence or online notarization and is either personally known to me or produced Drivers License as identification and acknowledged that he/she, being authorized to do so, executed this Joinder and Consent of Owner to Dock Easement, Covenants and Restrictions.

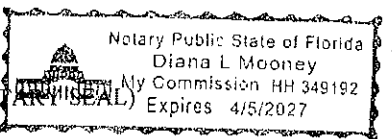
(AFFIX NOTARY SEAL)

[Signature]
Notary Public - State of Florida
Print Name: Diana L Mooney
My Commission Expires: 4/05/2027

STATE OF FLORIDA
COUNTY OF Hillsborough

I, Diana L Mooney, a Notary Public for said County and State, do hereby certify that Carmina Leigh Grose appeared before me this day by means of physical presence or online notarization and is either personally known to me or produced drivers license as identification and acknowledged that he/she, being authorized to do so, executed this Joinder and Consent of Owner to Dock Easement, Covenants and Restrictions.

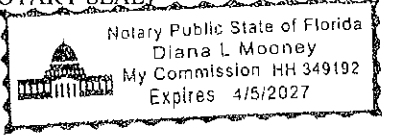
(AFFIX NOTARY SEAL)

[Signature]
Notary Public - State of Florida
Print Name: Diana L Mooney
My Commission Expires: 4/05/2027

EXHIBIT D:
Request for Review of Dock & Boat Lift Plans

HARBOR BAY COMMUNITY DEVELOPMENT DISTRICT

REQUEST FOR REVIEW OF DOCK & BOAT LIFT PLANS

The undersigned owner seeks review by the Harbor Bay Community Development District of the following proposed improvement (“Improvements”): Dock OR Boat Lift OR Other (Specify here: _____), at the following location:

Installation of a MiraBay B2 Dock and 16K Boat Lift

Application Must Include

- A. Complete specifications for the dock, mechanical lift or applicable option.
- B. Drawing showing dock / lift layout, location and spacing of the outer lift piling and showing the required wrapping of the piling.
- C. Provide the contractor’s name and attach a copy of their current license and proof of all necessary current and up-to-date insurance coverage.
- D. Recorded Dock Easement.

The CDD has adopted the MiraBay Master Dock Plan for Canal Lots (“Canal Lots Master Dock Plan”) and the MiraBay Master Dock Plan for Lagoon Lots (“Lagoon Lots Master Dock Plan,” and together with the Canal Lots Master Dock Plan, “Master Dock Plans”). The CDD’s review of the plans for the Improvements is limited to a determination of whether the Improvements are consistent with the Master Dock Plans, the District’s Southwest Florida Water Management District ERP No. 44-18838 (as amended from time to time), and the District’s rules, including but not limited to the Rule Regarding District Waterways and Boating Facilities. The undersigned property owner and listed contractor hereby acknowledge and agree that the undersigned shall be solely responsible for determining whether the improvements, alterations and/or additions described herein comply with all applicable laws, rules and regulations, code and ordinances, including, without limitation, zoning ordinances, subdivision regulations and current building codes, and shall further be responsible for obtaining all necessary legal rights to conduct the work and install and operate the Improvements, including but not limited to applicable permits, real estate rights, licenses, easements, HOA approvals, etc. The CDD shall have no liability or obligation to determine whether such improvements, alterations and/or additions comply with any such laws, rules, regulations, easements, codes or ordinances and/or whether any such rights and/or approvals have been obtained. Only the Improvements described herein are allowed. No substitutions, changes and/or alterations will be allowed without the express written approval of the CDD.

Applications must be received by the CDD Manager at jlansford@gms-tampa.com, 4648 Eagle Falls Place, Tampa, Florida 33619, (813)344-4844. **I agree to not begin work on improvements until I am notified in writing of the approval of the CDD. A fine may be imposed for any work started prior to approval.**

I understand and agree as follows:

- a) I have reviewed the Master Dock Plans and the rules and policies of the CDD.
- b) My lot may be permitted to have a dock only if: 1) the dock is shown on the applicable dock plan, whether that is the Canal Lots Master Dock Plan or the Lagoon Lots Master Dock Plan, 2) the type of dock I propose is shown on the applicable dock plan, whether that is the Canal Lots Master Dock Plan or the Lagoon Lots Master Dock Plan, and 3) the dock is approved in writing.
- c) All Power Boats must be registered with the CDD, and the total number of registered Power Boats permitted in MiraBay is limited. Therefore, I may not be allowed to register more than one Power Boat if my dock is approved. Any registrations issued for Power Boats in excess of one Power Boat per lot are revocable at any time by the District in the District's sole discretion. The submission of this form to the District shall operate as the applicant's absolute consent to this potential revocation and waiver of any right to compensation from the District as a result of such revocation.

I further acknowledge and agree that in the event I, or any other owner or occupant of my lot violates any of these requirements, or violates any other rules or guidelines governing docks, lifts, accessories, and the docking of vessels, that I will be personally liable for all costs and expenses related to bringing these items into compliance, plus attorney fees and costs, including attorney fees and costs on appeal. I further acknowledge and agree that the CDD shall have all rights and remedies available at law or equity to enforce these requirements, rules, and guidelines, including but not limited to imposition of a reasonable fine pursuant to the CDD's rules and policies, as may be amended from time to time.

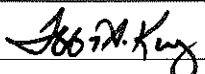
Property Owner Signature: 
Property Owner Name: <u>Jeffery King</u> Date: <u>03-09-2026</u>
Address: <u>5221 Wishing Arch Dr.</u>
City / State / Zip: <u>Apollo Beach, Fl. 33572</u>
Phone Number: <u>806-236-9082</u>

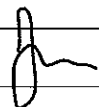
Contractor Signature: 
Contractor Name: <u>James March</u> Date: <u>03/09/2026</u>
Address: <u>8209 Stoner Woods Drive</u>
City / State / Zip: <u>Riverview, FL. 33569</u>
Phone Number: <u>813-800-3625</u>

PRIVACY NOTICE: Under Florida's Public Records Law, Chapter 119, Florida Statutes, the information you submit on this form may become part of a public record. This means that, if a citizen makes a public records request, we may be required to disclose the information you submit to us. Under certain circumstances, we may only be required to disclose part of the information submitted to us. If you believe that your records may qualify for an exemption under Chapter 119, Florida Statutes, please provide the affidavit required by Florida statute to the District Manager.

[CONTINUED ON NEXT PAGE]

RECOMMENDATION OF DISTRICT ENGINEER:

RECOMMEND APPROVAL, contingent on: _____

RECOMMEND DENIAL because _____

CDD BOARD APPROVAL:

APPROVED, contingent on: _____

NOTE: If this is for a Personal Water Craft lift located on the canal wall, the applicant must complete (1) the Canal Wall Connection Application; and (2) the License Agreement (Personal Watercraft Lift). Please see the attached Exhibit 1, incorporated by this reference, for the Canal Wall Application and License Agreement (Personal Watercraft Lift).

DENIED because _____

Exhibit 1
HARBOR BAY COMMUNITY DEVELOPMENT DISTRICT
4648 Eagle Falls Place, Tampa, Florida 33619
ATTN: District Manager

CANAL WALL CONNECTION APPLICATION

The undersigned (“**Owner**”) represent that they are the owners of record for the property described below (“**Property**”). The Owner desires to install and maintain a mechanical personal watercraft lift (“**Lift**”) on the canal retaining wall (a/k/a seawall) adjacent to the Property owned and maintained by the Harbor Bay Community Development District (“**CDD**”), and are submitting this application for that approval.

Owner(s) Name(s) Jeffery and Naomi King
Lot Street Address 5221 Wishing Arch Drive
City, State and Zip Code Apollo Beach Fl. 33572
Phone Number 806-236-9082
Lot Tax Folio Number 054191-2270

For Lifts being installed, please identify:

Contractor Name and License Number James March, SCC131152103

Contractor Phone Number 813-800-3625
(Attach Certificate of Insurance from Contractor)
Expected Start Date: Asap Expected Completion Date: _____

This Canal Wall Connection Application, as well as the attached *License Agreement (Personal Watercraft Lift)*, is to be signed by all parties named as grantee or transferee in the most recent deed or other conveyance instrument recorded in the Official Records of Hillsborough County for the Property. **Owner agrees to abide by the terms of the License Agreement (Personal Watercraft Lift).**

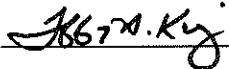
Owner Signature:  Date: 03-09-2026

Date: _____
Received by: _____
Harbor Bay Community Development District

For Office Use Only

APPROVED ___ DISAPPROVED ___
Explanation for Disapproval (if applicable): _____

PRIVACY NOTICE: Under Florida’s Public Records Law, Chapter 119, Florida Statutes, the information you submit on this form may become part of a public record. This means that, if a citizen makes a public records request, we may be required to disclose the information you submit to us. Under certain circumstances, we may only be required to disclose part of the information submitted to us. If you believe that your records may qualify for an exemption under Chapter 119, Florida Statutes, please provide the affidavit required by Florida statute to the District Manager.

ATTACHMENTS: LICENSE AGREEMENT & CDD SPECIFICATIONS (IF APPLICABLE)

This instrument was prepared by and upon recording should be returned to:

(This space reserved for Clerk)

District Counsel, Harbor Bay CDD
APPLETON REISS, PLLC
215 N. Howard Ave. STE 200
Tampa, FL 33606

Parcel ID for Property: U-29-31-19-C0L-000000-00005.0

**LICENSE AGREEMENT
(PERSONAL WATERCRAFT LIFT)**

This License Agreement (Personal Watercraft Lift) (“**Agreement**”) is entered into as of this _____ day of _____, 20²⁶, by and among:

The Harbor Bay Community Development District (“CDD”), a local unit of special purpose government created pursuant to Chapter 190, *Florida Statutes*; and

Jeffery King and Naomi King (together, “**Owner**”), the fee simple owners of the “**Property**” identified as:

Lot 5, Block , as per the plat (“**Plat**”) identified as MiraBay Parcel 8, and recorded in Plat Book 137, Pages 176-184 et seq., of the Public Records of Hillsborough County, Florida.

WITNESSETH:

WHEREAS, CDD is a special-purpose unit of local government that provides community infrastructure for the MiraBay community, including the community’s master storm water system and, as part of that, a canal retaining wall, which is also referred to as a seawall (“**Canal Wall**”); and

WHEREAS, Owner owns the Property within MiraBay; and

WHEREAS, as part of the Plat, among other things, CDD holds certain drainage and other easements (“**Easements**”) on the Property that allow CDD to install and maintain the Canal Wall and its related components; and

WHEREAS, Owner has requested authorization to install and maintain a mechanical personal watercraft lift (“**Lift**”) on the Canal Wall immediately adjacent to the Property; and

WHEREAS, subject to the terms of this Agreement, CDD desires to grant Owner a license to install and maintain the Lift;

NOW, THEREFORE, in exchange for the mutual promises set forth herein, the receipt and sufficiency of which are hereby acknowledged, it is understood and agreed as follows:

1. **Recitals.** The recitals set forth above are acknowledged as true and correct and are incorporated herein by reference.
2. **License for Installation & Maintenance of Lift; Limitation.** Subject to the terms of this

Agreement, CDD hereby grants Owner a non-exclusive, revocable license for the sole purpose of installing and maintaining the Lift on the Canal Wall. Owner acknowledges that this Agreement authorizes only installation and maintenance of the Lift on the Canal Wall, and does not authorize any other impact or other alteration to the Canal Wall.

3. **Owner Responsibilities.** Owner has the following responsibilities:

- a. Owner shall be fully responsible for the installation and maintenance of the Lift, including all costs, and shall conduct such work in accordance with any CDD-approved specifications, as amended from time to time.
- b. Owner shall use a licensed and insured contractor to perform any installation and maintenance work pursuant to this Agreement.
- c. Owner shall ensure that the installation and maintenance of the Lift does not interfere with the CDD's rights in the Easements, and does not damage any property of CDD or any third party's property. Among other things, Owner shall be responsible for restoring any impact to the grass swale behind the Canal Wall, and shall further ensure that any installation and/or maintenance does not damage the Canal Wall or other related improvements, including, but not limited to, tie-back anchors, cap, and sheeting. In the event of any such damage, Owner shall immediately notify CDD, in which case CDD, at CDD's option, shall either direct Owner to repair the damage at Owner's expense, or shall conduct such repairs at Owner's expense.
- d. Owner shall be responsible for ensuring that the installation and maintenance of the Lift are conducted in compliance with all applicable laws, rules, and regulations, including, but not limited to, building codes and set back requirements.
- e. Owner shall keep CDD's Easements free from any materialmen's or mechanic's liens and claims or notices in respect to such liens and claims, which arise by reason of the Owner's exercise of rights under this Agreement, and Owner shall immediately discharge any such claim or lien.
- f. CDD, by entering into this Agreement, does not represent that CDD has authority to provide all necessary approvals for connection of the Lift. Instead, the Owner shall be responsible for obtaining any and all applicable permits and approvals relating to the work, including, but not limited to, any approvals (if any) of the MiraBay Homeowners Association, Inc. ("**Association**") and any other necessary legal interests and approvals.
- g. Upon completion of the installation, the Lift will be owned by the Owner. Owner shall be responsible for the maintenance and repair of any such Lift, and agrees to maintain the Lift in good condition and consistent with any CDD-approved specifications, as amended from time to time.

4. **Existing Rights.** Nothing herein is intended to limit or diminish in any way the CDD's existing rights in the Easements. The permission granted herein is given to Owner as an accommodation and is revocable at any time. Owner acknowledges the legal interest of the CDD in the Easements described above and agrees never to deny such interest or to interfere in any way with CDD's use. Owner will exercise the privilege granted herein at Owner's own risk, and agrees that Owner will never claim any damages against CDD for any injuries or damages suffered on account of the exercise of such privilege, regardless of the fault or negligence of the CDD. Owner further acknowledges that, without notice, and without

recourse against the CDD, the CDD may revoke this Agreement and remove the Lift at Owner's expense, and that the CDD is not obligated to re-install the Lift as a result of the removal.

5. **Indemnification.** Owner agrees to indemnify, defend, and hold harmless the CDD, the Association, Hillsborough County, the Southwest Florida Water Management District, and any property management companies of the CDD and Association, as well as any officers, supervisors, staff, engineers, attorneys, agents and representatives of the foregoing (each an "Indemnitee"), against all liability for damages and expenses resulting from, arising out of, or in any way connected with, this Agreement or the exercise of the privileges granted hereunder. Provided however, nothing in this Agreement requires Owner to indemnify an Indemnitee for an Indemnitee's percentage of fault if the Indemnitee is adjudged to be more than 50% at fault for any claims against the Indemnitee and Owner as jointly liable parties; however, Owner shall indemnify an Indemnitee for any and all percentage of fault attributable to Owner for claims against an Indemnitee, regardless whether the Indemnitee is adjudged to be more or less than 50% at fault.

6. **Covenants Run with the Land.** This Agreement, and all rights and obligations contained herein, shall run with the land and shall be binding upon and inure to the benefit of the parties hereto and their respective heirs, successors and assigns, including, but without limitation, all subsequent owners of any portions of the property described herein and all persons claiming under them. Whenever the word "Owner" is used herein, it shall be deemed to mean the current owner of the Property and its successors and assigns. Upon the sale of the Property, Owner shall advise the subsequent owner of the terms and conditions of this Agreement. The CDD may at its option record this Agreement in the public records of Hillsborough County.

7. **Sovereign Immunity.** Nothing in this Agreement shall be deemed as a waiver of immunity or limits of liability of the CDD beyond any statutory limited waiver of immunity or limits of liability which may have been adopted by the Florida Legislature in Section 768.28, *Florida Statutes*, or other law, and nothing in this Agreement shall inure to the benefit of any third party for the purpose of allowing any claim which would otherwise be barred under the doctrine of sovereign immunity or by operation of law.

8. **Attorney's Fees & Costs.** The substantially prevailing party in any litigation to enforce the terms of this Agreement shall be entitled to reasonable attorney's fees, paralegal fees, expert witness fees, and costs.

9. **Counterparts.** This Agreement may be executed in counterparts. Any party hereto may join into this Agreement by executing any one counterpart. All counterparts when taken together shall constitute one agreement.

[SIGNATURES ON FOLLOWING PAGES]

IN WITNESS WHEREOF, the parties hereto have caused this License Agreement (Personal Watercraft Lift) to be executed the day and date first above written.

Witnesses:

Owner

By: Naomi J King
Naomi J King
Print Name

By: Naomi J King

5221 Wishing Arch Apollo Beach
Witness Address 1
FL, 33572
Witness Address 2

By: _____

Print Name _____

Witness Address 1 _____

Witness Address 2 _____

STATE OF ~~FLORIDA~~ TEXAS)
COUNTY OF COLLIN)

The foregoing instrument was acknowledged before me this 11 day of MARCH, 2026, by Naomi King + Jack King (He/She/It) is personally known to me or [] produced _____ as identification.

[Signature]
NOTARY PUBLIC

RAQUEL ADAMS
(Print, Type or Stamp Commissioned Name of Notary Public)



[Signatures continue on following page]

[SIGNATURE PAGE TO LICENSE AGREEMENT (PERSONAL WATERCRAFT LIFT)]

Witnesses:

By: JEFF KING

JEFF KING

Print Name

5221 WISHING ARCH

Witness Address 1

ARROW BEH, FL 33572

Witness Address 2

By: _____

Print Name

Witness Address 1

Witness Address 2

STATE OF ~~FLORIDA~~ TEXAS)

COUNTY OF COLLIN)

The foregoing instrument was acknowledged before me this 11 day of MARCH, 2026 by JEFF KING. He/she is personally known to me or produced _____ as identification.

[Signature]

NOTARY PUBLIC

RAQUEL ADAMS
(Print, Type or Stamp Commissioned Name of Notary Public)

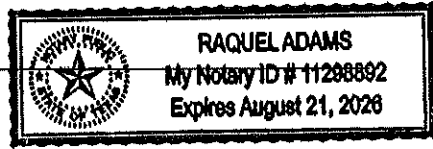

[Signatures continue on following page]

[SIGNATURE PAGE TO LICENSE AGREEMENT (PERSONAL WATERCRAFT LIFT)]

Witnesses:

**Harbor Bay
Community Development District**

By: _____

By: _____

Print Name

As Chairman / Vice Chairman of the Board of
Supervisors

Witness Address 1

Witness Address 2

By: _____

Print Name

Witness Address 1

Witness Address 2

STATE OF FLORIDA)

COUNTY OF _____)

The foregoing instrument was acknowledged before me this ____ day of _____, 20__, by _____, as Secretary of the Board of Supervisors of the Harbor Bay Community Development District, on behalf of said District. He/she [] is personally known to me or [] produced _____ as identification.

NOTARY PUBLIC

(Print, Type or Stamp Commissioned Name of Notary Public)

[End of signature pages]

EXHIBIT E:
Utilities Connection Application

HARBOR BAY COMMUNITY DEVELOPMENT DISTRICT

4648 Eagle Falls Place, Tampa, Florida 33619

ATTN: District Manager

UTILITIES CONNECTION APPLICATION

The undersigned ("Owner") represent that they are the owners of record for the property described below ("Property"). The Owner desires to install (which shall include, without limitation, any reconnection work) and maintain power and water lines through the canal retaining wall (a/k/a seawall) adjacent to the Property owned and maintained by the Harbor Bay Community Development District ("CDD"), and are submitting this application for that approval.

Owner(s) Name(s) Jeffery and Naomi King

Lot Street Address 5221 Wishing Arch Dr.

City, State and Zip Code Apollo Beach Fl. 33572

Phone Number 806-236-9082

Lot Tax Folio Number 054191-2270

<p>For power and water lines being installed (which shall include, without limitation, the reconnection of existing lines) please identify:</p> <p>Contractor Name and License Number <u>James March SC131152103</u></p> <hr/> <p>Contractor Phone Number <u>813-800-3625</u></p> <p>(Attach Certificate of Insurance from Contractor)</p> <p>Expected Start Date: <u>Asap</u> Expected Completion Date: _____</p>
--

This Utilities Connection Application, as well as the attached *License Agreement (Utilities Connection)*, is to be signed by all parties named as grantee or transferee in the most recent deed or other conveyance instrument recorded in the Official Records of Hillsborough County for this property. **Owner agrees to abide by the terms of the License Agreement (Utilities Connection).**

Owner Signature: *Jeffery King* Date: 03-09-2026

Co-Owner Signature: *Naomi King* Date: 3-10-2026

Date: _____

Received by: _____

Harbor Bay Community Development District

<p>For Office Use Only</p> <p>APPROVED ___ DISAPPROVED ___</p> <p>Explanation for Disapproval (if applicable): _____</p> <p>_____</p> <p>_____</p>

PRIVACY NOTICE: Under Florida's Public Records Law, Chapter 119, Florida Statutes, the information you submit on this form may become part of a public record. This means that, if a citizen makes a public records request, we may be required to disclose the information you submit to us. Under certain circumstances, we may only be required to disclose part of the information submitted to us. If you believe that your records may qualify for an exemption under Chapter 119, Florida Statutes, please provide the affidavit required by Florida statute to the District Manager.

ATTACHMENTS: LICENSE AGREEMENT & CDD SPECIFICATIONS (IF APPLICABLE)

This instrument was prepared by and upon recording should be returned to:

(This space reserved for Clerk)

District Counsel, Harbor Bay CDD
APPLETON REISS, PLLC
215 N. Howard Ave. Ste. 200
Tampa, FL 33606

Parcel ID for Property: U-29-31-19-COL-000000-00005.0

**LICENSE AGREEMENT
(UTILITIES CONNECTION)**

This License Agreement (Utilities Connection) (“**Agreement**”) is entered into as of this ____ day of _____, 2026, by and among:

The Harbor Bay Community Development District (“CDD”), a local unit of special purpose government created pursuant to Chapter 190, *Florida Statutes*; and

Jeffery King and Naomi King
(together, “**Owner**”), the fee simple owners of the “**Property**” identified as:

Lot 5, Block __, as per the plat (“**Plat**”) identified as MiraBay Parcel 8 and recorded in Plat Book 137, Pages 176-184 et seq., of the Public Records of Hillsborough County, Florida.

WITNESSETH:

WHEREAS, CDD is a special purpose unit of local government that provides community infrastructure for the MiraBay community, including the community’s master storm water system and, as part of that, a canal retaining wall, which is also referred to as a seawall (“**Canal Wall**”); and

WHEREAS, Owner owns the Property within MiraBay; and

WHEREAS, as part of the Plat, among other things, CDD holds certain drainage and other easements (“**Easements**”) on the Property that allow CDD to install and maintain the Canal Wall and its related components; and

WHEREAS, Owner has requested authorization to install (which shall include, without limitation, any reconnection work) and maintain power and water utility lines (“**Utility Lines**”) through the Canal Wall and to Owner’s dock; and

WHEREAS, in order to accommodate such requests, CDD has installed conduits in the Canal Wall for certain lots, and/or established a specification for the placement of Utility Lines through the Canal Wall for other lots (together, “**Utility Pass-Throughs**”); and

WHEREAS, subject to the terms of this Agreement, CDD desires to grant Owner a license to install and maintain the Utility Lines using the Utility Pass-Throughs;

NOW, THEREFORE, in exchange for the mutual promises set forth herein, the receipt and sufficiency of which are hereby acknowledged, it is understood and agreed as follows:

10. **Recitals.** The recitals set forth above are acknowledged as true and correct and are incorporated herein by reference.

11. **License for Installation & Maintenance of Utility Lines; Limitation.** Subject to the terms of this Agreement, CDD hereby grants Owner a non-exclusive, revocable license to use the CDD-authorized Utility Pass-Throughs for the sole purpose of installing and maintaining the Utility Lines through the Canal Wall and to the dock at the Property. Owner acknowledges that this Agreement authorizes only the connection and maintenance of power and water utilities through the Canal Wall, and does not authorize any other impact or other alteration to the Canal Wall.

12. **Owner Responsibilities.** Owner has the following responsibilities:

- a. Owner shall be fully responsible for the installation and maintenance of the Utility Lines, including all costs, and shall conduct such work in accordance with any CDD-approved specifications, as amended from time to time.
- b. Owner shall ensure that any connection of Utility Lines through the Canal Wall is done using the CDD-authorized Utility Pass-Throughs.
- c. Owner shall use a licensed and insured contractor to perform any installation and maintenance work pursuant to the Agreement.
- d. Owner shall ensure that the installation and maintenance of the Utility Lines does not interfere with the CDD's rights in the Easements, and does not damage any property of CDD or any third party's property. Among other things, Owner shall be responsible for restoring any impact to the grass swale behind the Canal Wall, and shall further ensure that any installation and/or maintenance does not damage the Canal Wall or other related improvements, including, but not limited to, tie-back anchors, cap, and sheeting. In the event of any such damage, Owner shall immediately notify CDD, in which case CDD, at CDD's option, shall either direct Owner to repair the damage at Owner's expense, or shall conduct such repairs at Owner's expense.
- e. Owner shall be responsible for ensuring that the installation and maintenance of the Utility Lines are conducted in compliance with all applicable laws, rules, and regulations, including, but not limited to, building codes and set back requirements.
- f. Owner shall keep CDD's Easements free from any materialmen's or mechanic's liens and claims or notices in respect to such liens and claims, which arise by reason of the Owner's exercise of rights under this Agreement, and Owner shall immediately discharge any such claim or lien.
- g. CDD, by entering into this Agreement, does not represent that CDD has authority to provide all necessary approvals for connection of the Utility Lines. Instead, the Owner shall be responsible for obtaining any and all applicable permits and approvals relating to the work, including, but not limited to, any approvals (if any) of the MiraBay Homeowners Association, Inc. ("**Association**") and any other necessary legal interests and approvals.
- h. Upon completion of the installation, the Utility Lines will be owned by the Owner. Owner shall be responsible for the maintenance and repair of any such Utility Lines, and agrees to maintain the Utility Lines in good condition and consistent with any CDD-approved specifications, as amended from time to time.

13. **Existing Rights.** Nothing herein is intended to limit or diminish in any way the CDD's existing rights in the Easements. The permission granted herein is given to Owner as an accommodation and is revocable at any time. Owner acknowledges the legal interest of the CDD in the Easements described

above and agrees never to deny such interest or to interfere in any way with CDD's use. Owner will exercise the privilege granted herein at Owner's own risk, and agrees that Owner will never claim any damages against CDD for any injuries or damages suffered on account of the exercise of such privilege, regardless of the fault or negligence of the CDD. Owner further acknowledges that, without notice, and without recourse against the CDD, the CDD may revoke this Agreement and remove the Utility Lines at Owner's expense, and that the CDD is not obligated to re-install the Utility Lines as a result of the removal.

14. **Indemnification.** Owner agrees to indemnify, defend, and hold harmless the CDD, the Association, Hillsborough County, the Southwest Florida Water Management District, and any property management companies of the CDD and Association, as well as any officers, supervisors, staff, engineers, attorneys, agents and representatives of the foregoing (each an "Indemnitee"), against all liability for damages and expenses resulting from, arising out of, or in any way connected with, this Agreement or the exercise of the privileges granted hereunder. Provided however, nothing in this Agreement requires Owner to indemnify an Indemnitee for an Indemnitee's percentage of fault if the Indemnitee is adjudged to be more than 50% at fault for any claims against the Indemnitee and Owner as jointly liable parties; however, Owner shall indemnify an Indemnitee for any and all percentage of fault attributable to Owner for claims against an Indemnitee, regardless whether the Indemnitee is adjudged to be more or less than 50% at fault.

15. **Covenants Run with the Land.** This Agreement, and all rights and obligations contained herein, shall run with the land and shall be binding upon and inure to the benefit of the parties hereto and their respective heirs, successors and assigns, including, but without limitation, all subsequent owners of any portions of the property described herein and all persons claiming under them. Whenever the word "Owner" is used herein, it shall be deemed to mean the current owner of the Property and its successors and assigns. Upon the sale of the Property, Owner shall advise the subsequent owner of the terms and conditions of this Agreement. The CDD may at its option record this Agreement in the public records of Hillsborough County.

16. **Sovereign Immunity.** Nothing in this Agreement shall be deemed as a waiver of immunity or limits of liability of the CDD beyond any statutory limited waiver of immunity or limits of liability which may have been adopted by the Florida Legislature in Section 768.28, *Florida Statutes*, or other law, and nothing in this Agreement shall inure to the benefit of any third party for the purpose of allowing any claim which would otherwise be barred under the doctrine of sovereign immunity or by operation of law.

17. **Attorney's Fees & Costs.** The substantially prevailing party in any litigation to enforce the terms of this Agreement shall be entitled to reasonable attorney's fees, paralegal fees, expert witness fees, and costs.

18. **Counterparts.** This Agreement may be executed in counterparts. Any party hereto may join into this Agreement by executing any one counterpart. All counterparts when taken together shall constitute one agreement.

[SIGNATURES ON FOLLOWING PAGES]

IN WITNESS WHEREOF, the parties hereto have caused this License Agreement (Utilities Connection) to be executed the day and date first above written.

Witnesses:

By: Naomi King
Naomi J. King

Print Name

5221 Wishing Arch

Witness Address 1

Apollo Beach, FL 33572

Witness Address 2

By: _____

Print Name

Witness Address 1

Witness Address 2

STATE OF ~~FLORIDA~~ TEXAS)

COUNTY OF COLLIN)

The foregoing instrument was acknowledged before me this 11 day of MARCH, 2026 by Naomi King. He/she is personally known to me or [] produced _____ as identification.

[Signature]
NOTARY PUBLIC

RAQUEL ADAMS
(Print, Type or Stamp Commissioned Name of _____)

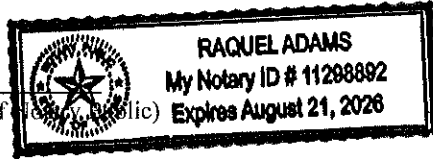

[Signatures continue on following page]

[SIGNATURE PAGE TO LICENSE AGREEMENT (UTILITIES CONNECTION)]

Witnesses:

By: Jeff King
JEFF KING

Print Name

5221 WISHING ARCH

Witness Address 1

APOLLO BECH, FL 33572

Witness Address 2

By: _____

Print Name

Witness Address 1

Witness Address 2

STATE OF ~~FLORIDA~~ TEXAS)

COUNTY OF COLLIN)

The foregoing instrument was acknowledged before me this 11 day of MARCH, 2022, by JEFF KING . she is personally known to me or produced _____ as identification.

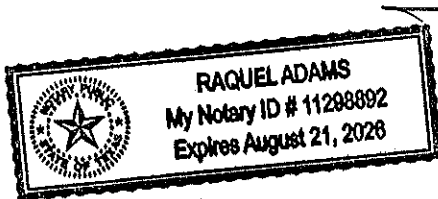

[Signature]
NOTARY PUBLIC

RAQUEL ADAMS
(Print, Type or Stamp Commissioned Name of Notary Public)

[Signatures continue on following page]

[SIGNATURE PAGE TO LICENSE AGREEMENT (UTILITIES CONNECTION)]

Witnesses:

**Harbor Bay
Community Development District**

By: _____

By: _____

Print Name

As Chairman / Vice Chairman of the Board of
Supervisors

Witness Address 1

Witness Address 2

By: _____

Print Name

Witness Address 1

Witness Address 2

STATE OF FLORIDA)

COUNTY OF _____)

The foregoing instrument was acknowledged before me this ____ day of _____, 20__, by _____, as Secretary of the Board of Supervisors of the Harbor Bay Community Development District, on behalf of said District. He/she [] is personally known to me or [] produced _____ as identification.

NOTARY PUBLIC

(Print, Type or Stamp Commissioned Name of Notary Public)

[End of signature pages]

March Marine Construction

Jeffery King & Naomi King

Physical Address:

5221 Wishing Arch Dr.

Apollo Beach, FL 33592

Mailing Address:

990 Fox Bend Way,

Prosper, TX 75078-7024

Plan View:

Scale: 1" = 16'

We Will Be:

- Installing a 4' x 28' Pier to a 10' by 12' Dock.

- Installing a 16k Davit Master Boat lift.

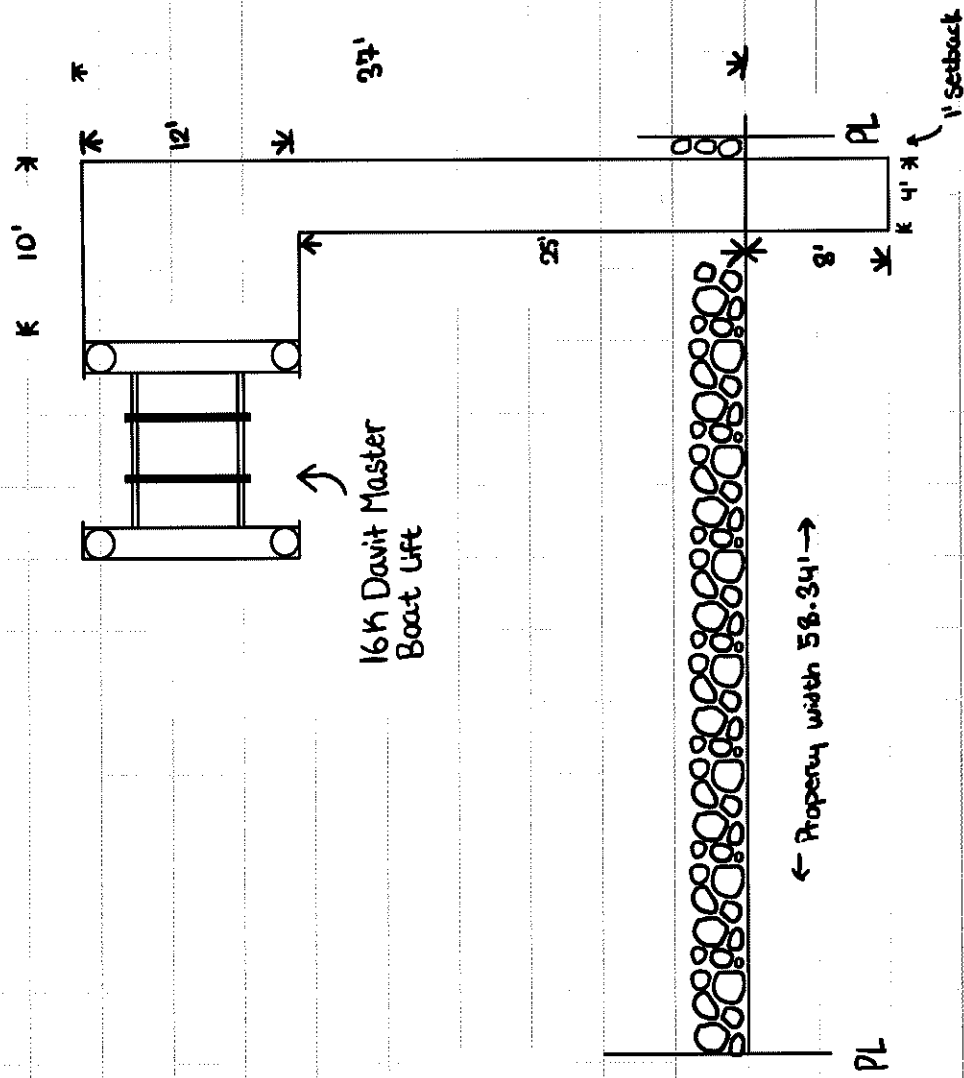

March Marine Construction

Jeffery King & Naomi King

Physical Address:

5221 Wishing Arch Dr.

Apollo Beach, FL 33542

Mailing Address:

970 Fox Bend Way

Prosper, TX 75078-7024

Profile View

Scale: 1" = 8'

We Will Be:

- Installing a 4' x 25' Pier to a 10' by 12' Dock.
- Installing a 16k Davit Master Boat lift.

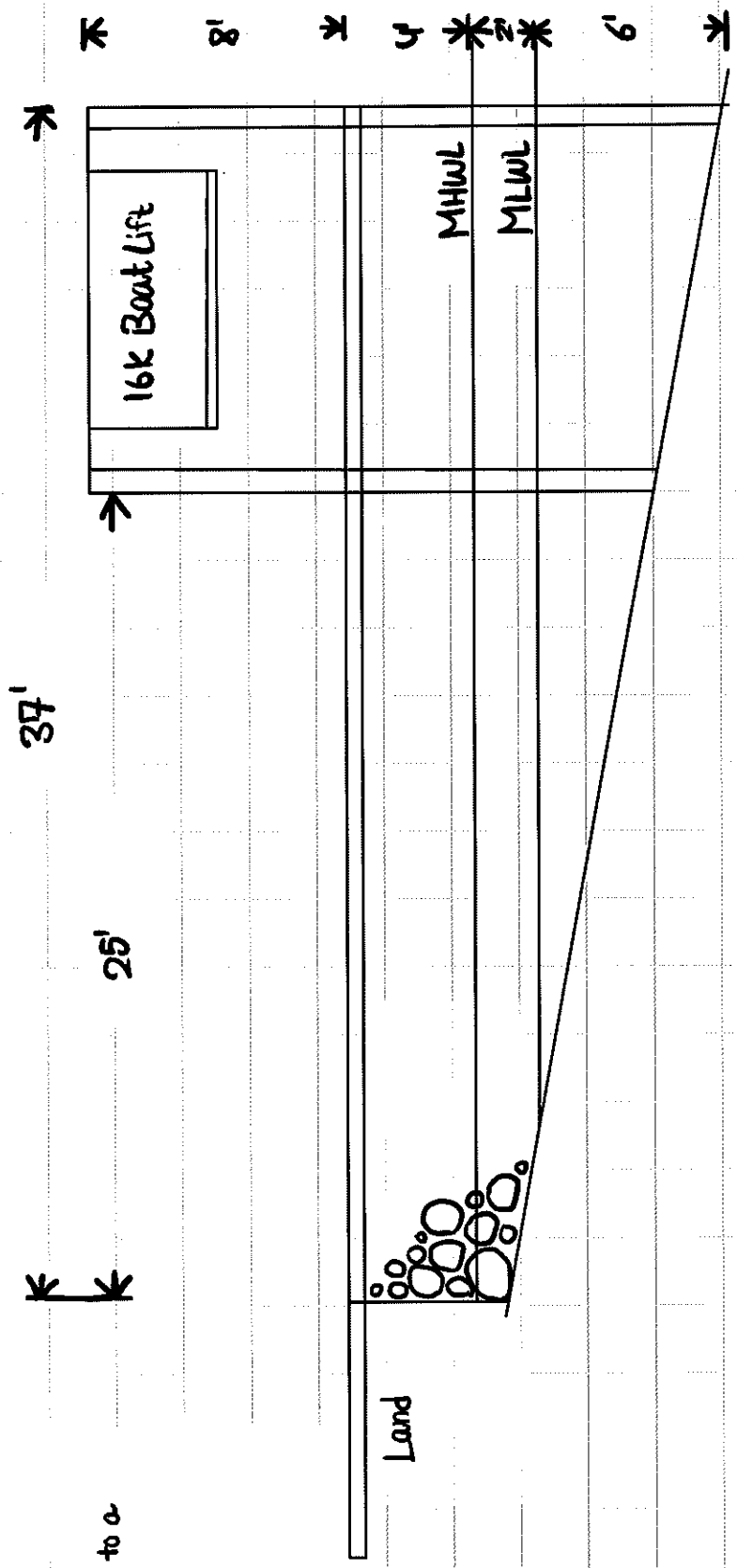

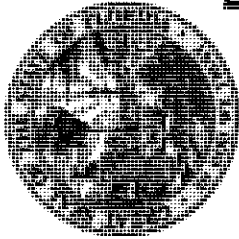

Ron DeSantis, Governor

Melanie S. Griffin, Secretary



**STATE OF FLORIDA
DEPARTMENT OF BUSINESS AND PROFESSIONAL REGULATION**

CONSTRUCTION INDUSTRY LICENSING BOARD

THE MARINE SPECIALTY CONTRACTOR HEREIN IS CERTIFIED UNDER THE
PROVISIONS OF CHAPTER 489, FLORIDA STATUTES

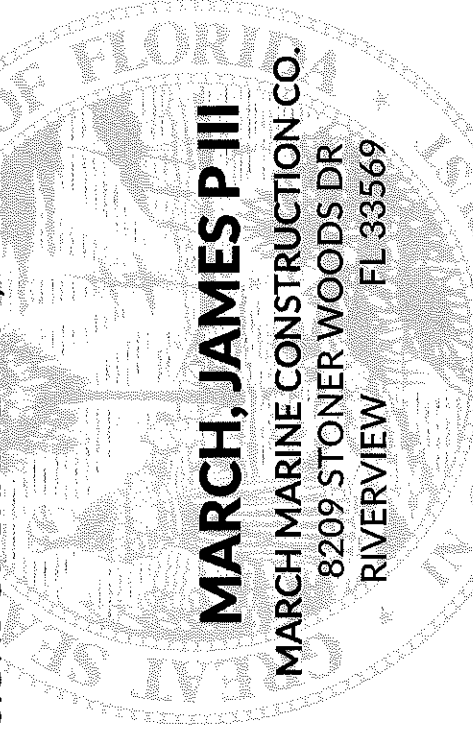

MARCH, JAMES P III
MARCH MARINE CONSTRUCTION CO.
8209 STONER WOODS DR
RIVERVIEW FL 33569

LICENSE NUMBER: SCC131152103

EXPIRATION DATE: AUGUST 31, 2026

Always verify licenses online at MyFloridaLicense.com



ISSUED: 06/26/2024

Do not alter this document in any form.

This is your license. It is unlawful for anyone other than the licensee to use this document.

Consideration: \$3,500.00
Documentary Stamps Paid: \$24.50

Prepared by and when
Recorded return to:

Shutts & Bowen LLP
Tirso M. Carreja, Jr., Esq.
4301 W. Boy Scout Boulevard
Suite 300
Tampa, Florida 33607

**DECLARATION OF DOCK EASEMENT, COVENANTS
AND RESTRICTIONS FOR
LOT 5 PARCEL 8
PER PLAT BOOK 137, PAGE 176, OF THE PUBLIC RECORDS OF
HILLSBOROUGH COUNTY, FLORIDA**

THIS DECLARATION OF DOCK EASEMENT, COVENANTS AND RESTRICTIONS (the "**Dock Easement Declaration**") is made, executed, granted, imposed and declared this 10th day of January, 2024, by **PARK SQUARE ENTERPRISES, LLC**, a Delaware limited liability company ("**Park Square**") to and in favor of the Owner (as that term is defined below) of Lot 5, MiraBay Parcel 8, according to the plat thereof (the "**Plat**") recorded in Plat Book 137, Page 176, of the Public Records of Hillsborough County, Florida ("**Benefitted Lot**").

RECITALS

A. The term "**Owner**" shall mean and refer to the fee simple record owner of the Benefitted Lot. The term "**Dock Structure**" shall refer to a dock consisting of a deck/walking surface on pilings and/or floatation devices or materials now or hereafter constructed in the Tract (hereinafter defined), and which is located adjacent to the rear boundary line of the Benefitted Lot, and may include boat lift pilings as described in Article I below, all subject to approval as provided in Article III below.

B. Park Square is the fee simple record owner of **Tract "C-8"** on **Sheet 10** of that certain **Mira Bay Phase 1B-1/2A-1/3B-1**, according to the plat thereof recorded in **Plat Book 94, Page 41**, of the Public Records of Hillsborough County, FL (**the "Tract"**).

C. The Tract contains a canal (the canal sometimes being referred to herein as the "**Waterbody**"), which is adjacent to, and shares a common boundary line with, the Benefitted Lot. Park Square wishes to grant to the Owner of the Benefitted Lot certain rights to own, maintain and enjoy a Dock Structure located in the Waterbody, subject to the terms and conditions set forth herein.

ARTICLE I
EASEMENT FOR DOCK STRUCTURE

For \$10.00 and other valuable consideration, the receipt of which is hereby acknowledged, Park Square does hereby give, grant and convey to the Owner of the Benefitted Lot a perpetual non-exclusive easement (the "**Dock Easement**") to own, maintain, repair and replace, at Owner's sole cost and expense, a Dock Structure adjacent to the Benefitted Lot. The Dock Easement granted by this Article is on and over that portion of the Tract lying immediately under the Dock Structure at the location where the Dock Structure is

approved as provided in Article III below, and includes the right to own, maintain, repair and replace pilings on the bottom of the Tract at the locations where the pilings supporting the Dock Structure and/or boat lift are approved pursuant to Article III below (the "**Dock Easement Area**"). The Dock Easement includes the right, and the Owner of the Benefitted Lot is hereby granted, a perpetual non-exclusive easement to install boat lift pilings (i.e., inner and outer boat lift pilings, which are designed as the supports of a boat lift) on the bottom of the Tract, subject to approval of any such boat lift pilings as described in Article III below.

After the Dock Structure is approved pursuant to Article III below, Park Square shall have the right (but not the obligation) to record in the public records a notice (a "**Notice of Dock Easement Area**") describing (by metes and bounds description or by means of a sketch) the Dock Easement Area, in order to provide future purchasers of the Benefitted Lot record notice of the Dock Easement Area covered by this Dock Easement. No party other than Park Square shall be required to join in, or consent to, the Notice of Dock Easement Area in order to make it effective and binding on the Owner or any mortgagee of the Benefitted Lot. The Dock Easement granted by this Article I shall be confined to the Dock Easement Area.

ARTICLE II

EASEMENT FOR OTHER DOCK ENCROACHMENTS

Some portions of the Dock Structure may inadvertently encroach slightly into a "dock easement area" serving an adjoining Lot, and the "dock structure" constructed on an adjoining Lot may encroach slightly into the Dock Easement Area serving the Benefitted Lot. If such an encroachment exists as the result of the original construction of a "dock structure" or the Dock Structure as approved, as applicable, any such encroaching structure shall also automatically have and is hereby granted an easement for such encroachment so long as it exists. In the event any encroaching dock structure or the Dock Structure must be replaced in the future, the replacement dock structure or Dock Structure, as applicable, shall have an easement for an encroachment of the same degree and size as the original encroaching structure, subject to approval of any replacement structure as required by Article III below.

ARTICLE III

APPROVAL OF DOCK STRUCTURE

This Dock Easement Declaration grants only easement rights in the Tract owned by Park Square, as expressly provided herein. Nothing in this Dock Easement Declaration shall be deemed an authorization to construct, or the approval of, any Dock Structure, associated pilings, any boat, other watercraft, any water fixtures, or any other improvement, fixtures, or property associated with the Dock Structure, or otherwise, within the Waterbody, all of which are subject to the approval of Harbor Bay Community Development District (its successors or assigns, the "**CDD**") in accordance with the MiraBay Master Dock Plan, the Harbor Bay Community Development District Rule Regarding District Waterways and Boating Facilities (as amended, restated, and/or supplemented from time to time), and any other rules, restrictions, requirements or guidelines promulgated by the CDD, from time to time, related to improvements and property within the Waterbody (collectively, the "**Dock Rules**"). Owner should obtain the Dock Rules from the CDD, and Owner must obtain the CDD's approval prior to constructing any improvement or maintaining any property within the Waterbody. Park Square makes no representation or warranty that the CDD will grant any approvals to Owner.

ARTICLE IV

COVENANTS AND RESTRICTIONS

1. The Dock Rules may include, without limitation, rules regarding approval and registration of boats and other watercraft, the total number of watercraft in MiraBay, the maximum length of watercraft that may be docked in MiraBay (all of which may differ between the Benefitted Lot and any other lot in MiraBay),

and rules regarding the maintenance of dock structures, watercrafts, and other improvements and property within the Waterbody. The existence of any dock, watercraft, property or fixture, or the condition thereof, shall not be deemed a representation or warranty that any such dock, watercraft, property, fixture, or condition will be approved or permitted with respect to the Benefitted Lot.

2. The Owner of the Benefitted Lot shall repair and maintain the Dock Structure in good condition and repair, at Owner's sole cost and expense, and if necessary shall replace the Dock Structure from time to time, all subject to the Dock Rules. If Owner fails to maintain, repair or replace the Dock Structure as required by this section, then Park Square shall have the right, but not the obligation, to perform such maintenance, repair or replacement at the Owner's sole cost and expense, and Owner shall reimburse such amounts to Park Square within ten (10) days of written demand to Owner. If Owner fails to reimburse Park Square as required by this section within such 10-day period, then the amount due by Owner to Park Square shall accrue interest at the rate of ten percent (10%) per annum from the date due until actually paid, and Park Square shall have the right to record a lien in the Public Records against title to the Benefitted Lot and/or Owner's interest in the Dock Easement and Dock Easement Area, to secure any amount owed by Owner to Park Square in accordance with this section, and to foreclose on such lien in accordance with Florida law.

3. The Owner of the Benefitted Lot, by joining herein or by taking title to the Benefitted Lot, as applicable, agrees to and shall indemnify and hold harmless Park Square, the CDD, the MiraBay Homeowners Association, Inc., Park Square Enterprises, LLC d/b/a Park Square Homes, and their respective officers, directors, partners, members, shareholders, employees, agents and affiliates of every tier, and each affiliate's officers, directors, agents and employees (all of the foregoing collectively, the "Indemnified Parties"), from and against any claims, losses or liabilities arising out of or related to the easement rights granted herein or construction or use of any Dock Structure, watercraft, fixtures, or other property or improvements, by any party. The Owner's obligation to indemnify the Indemnified Parties shall include, without limitation: (a) claims arising out of accidents occurring on, or as a result of a person falling or jumping from, a Dock Structure, watercraft, fixtures, or other property or improvements; (b) claims arising out of the utilization of the Dock Structure or other improvements to tie up or hoist a watercraft; (c) claims arising out of watercraft or persons running into the Dock Structure, fixtures, or other property or improvements; (d) claims arising out of Owner's, its family, guests, contractors and subcontractors, and employees dumping of any debris in the Waterbody; and (e) Owner's, its guests' or invitees' non-compliance with the Dock Rules, or failure to obtain approval of any Dock Structure, watercraft, fixtures, or other property or improvements as required by Article III above.

ARTICLE V
MISCELLANEOUS

Article and paragraph captions are for reference only, and shall not be considered in interpreting the contents of any Article or paragraph, nor shall they be deemed to limit the scope of any Article or paragraph. In any legal or arbitration proceeding arising out of or related to this Dock Easement Declaration, the prevailing party shall be entitled to recover its attorneys' fees and costs incurred in connection with such proceeding. This Dock Easement Declaration shall constitute covenants and restrictions running with the land, both benefitting and burdening title to the Benefitted Lot and the portion of the Tract constituting the Dock Easement Area. This Dock Easement Declaration may not be amended except in writing signed by the fee simple owner of the Benefitted Lot and the fee simple owner of the Tract.

(REMAINDER OF PAGE INTENTIONALLY LEFT BLANK)

(SIGNATURES PAGE TO FOLLOW)

IN WITNESS WHEREOF, the Park Square has executed this Dock Easement Declaration.

Signed, sealed and delivered in the presence of:

PARK SQUARE ENTERPRISES, LLC, a Delaware limited liability company

Heather Espina
Print Name: Heather Espina
Address: 205 Manas Harbor Dr.
Apolla Beach FL 33572
Barbara Di Rose
Print Name: BARBARA Di Rose
Address: 205 Manas Harbor Dr.
Apolla Beach FL 33572

By: [Signature]
Name: Randy Turkovics
Title: VP of Ops
Date: 1/19/24
Address: 5200 Vineland Road, Ste. 200
Orlando, FL 32811

STATE OF FLORIDA)
COUNTY OF HILLSBOROUGH)

I, Heather Espina, a Notary Public for said County and State, do hereby certify that Randy Turkovics appeared before me this day by means of physical presence or online notarization and is either personally known to me or produced as identification and acknowledged that s/he is the VP of Ops of PARK SQUARE ENTERPRISES, LLC, a Delaware limited liability company, and that s/he, as VP of Ops, being authorized to do so, executed this Dock Easement Declaration on behalf of PARK SQUARE ENTERPRISES, LLC, a Delaware limited liability company.



[Signature]
Notary Public - State of Florida
Print Name: Heather Espina
My Commission Expires: 2/17/2024

JOINER AND CONSENT OF OWNER(S)

The undersigned Owner(s) hereby joins in and consents to the Dock Easement, Covenants and Restrictions to which this joinder and consent is attached.

WITNESSES:

OWNER:

Barbara DiRose
Print Name: BARBARA DiRose
Address: 205 Manns Harbor Dr
Apollo Beach, FL 33572

Heather Espina
Print Name: Heather Espina
Address: 205 Manns Harbor Dr
Apollo Beach, FL 33572

CLAUDINE WINGLE REVOCABLE TRUST
DATED FEBRUARY 24, 2022

Claudine Patrice Wingle Trustee
Claudine Patrice Wingle, Trustee
Date: 1/19/24
Address: 5221 Wishing Arch Drive
Apollo Beach, FL 33572

STATE OF FLORIDA
COUNTY OF Hillsborough

Heather Espina, a Notary Public for said County and State, do hereby certify that **Claudine Patrice Wingle** appeared before me this day by means of physical presence or online notarization and is either personally known to me or produced as identification and acknowledged that he/she, being authorized to do so, executed this Joinder and Consent of Owner to Dock Easement, Covenants and Restrictions individually and as Trustee of the Claudine Wingle Revocable Trust dated February 24, 2022.

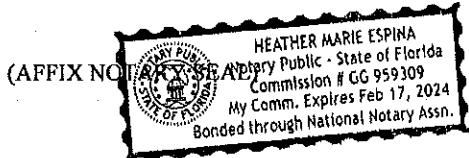

Heather Espina
Notary Public - State of Florida
Print Name: Heather Espina
My Commission Expires: 2/17/2024

Tab 8



MEMORANDUM

TO: Harbor Bay Community Development District
FROM: Bradley S. Foran, P.E.
DATE: 3/30/2026
RE: Marisol Pointe Seawall Depressions

On 3/27/2026, we performed a site visit to observe seawall depressions on Marisol Pointe. Below are our observations:

5947 Blakeney Loop:

Multiple depressions were observed along the easement of this property.



MEMORANDUM

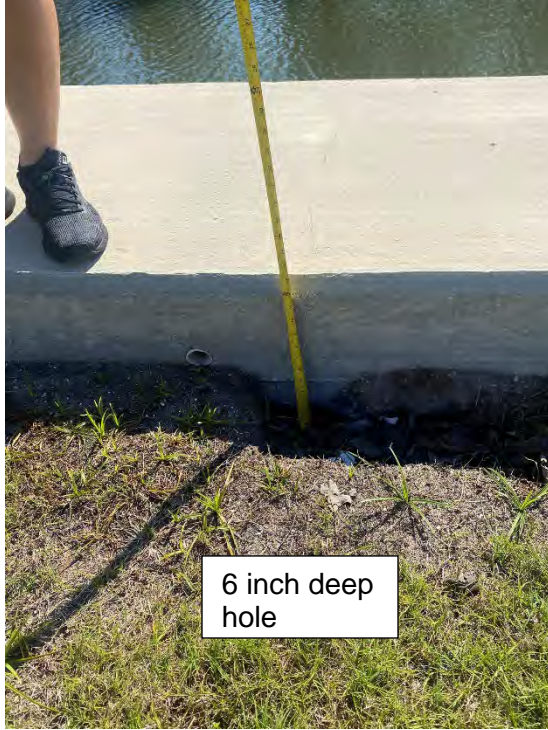

MEMORANDUM

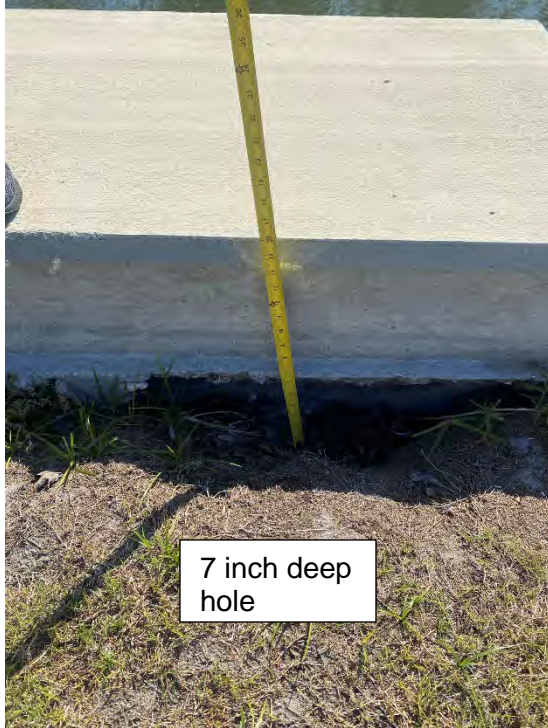

MEMORANDUM

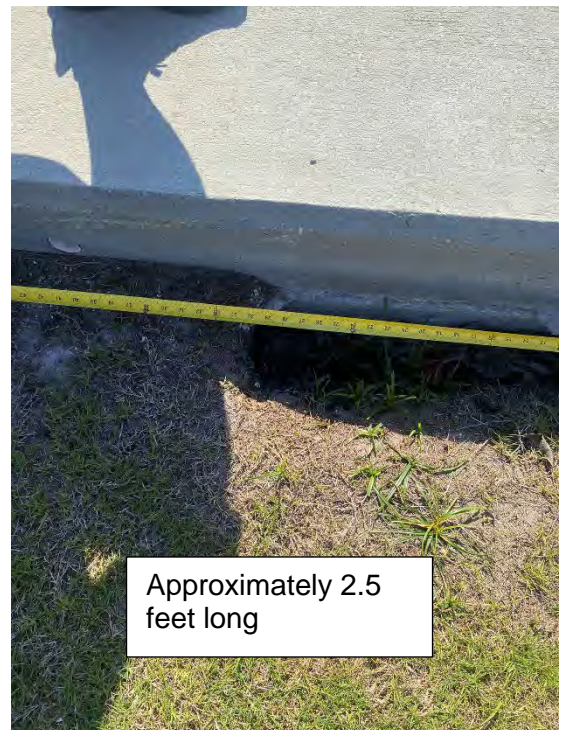

MEMORANDUM



MEMORANDUM

5943 Blakeney Loop



13 inch deep hole



Approximately 17
inches long

MEMORANDUM

958 Signet Drive



MEMORANDUM

970 Signet Drive



MEMORANDUM

1022 Signet Drive



MEMORANDUM

1046 Signet Drive



16 inch deep hole



Approximately 17 inches long



1 foot deep hole



Approximately 17 inches long



MEMORANDUM

1050 Signet Drive



MEMORANDUM

1080 Signet Drive



16 inch deep hole



Approximately 17
inches long

Tab 9

HARBOR BAY COMMUNITY DEVELOPMENT DISTRICT

District Office – Wesley Chapel, Florida (813) 994-1001
Mailing Address – 3434 Colwell Avenue Suite 200, Tampa, Florida 33614
www.harborbaycdd.org

District Coordinator Report

Date of report: April 8, 2026

Submitted by: Clay Wright

1. Landscape & Grounds Management

- Bi-weekly landscape inspections with Lee Te Kim Landscaping.
- Oversight of approved landscaping proposals. Current major projects include Mirabay entrance re-landscaping and beginning work on clubhouse pool re-landscaping.

2. Infrastructure & Capital Projects

- Coordinated the start of the roof replacement at the clubhouse and Dockers. Establishing schedule, timeline, closures, and coordinating communication between contractors and management.
- Executed final form agreement for pool slide stairs repair and verified permitting requirements. Project start TBD based on lead time for fiberglass treads.
- Collected 3 proposals and surveys for sidewalk grinding throughout the district.
- Conducted walkthrough with Air Prime Solutions to get a snapshot of our HVAC infrastructure and condition. Proposal requested for a full audit and condition report with recommended replacement/maintenance timelines.
- Conducted seawall inspection at Marisol Pointe with district engineer.

3. Amenities & Aquatics Oversight

- Monthly aquatics walkthroughs with Blue Water Aquatics.
- Coordinated mobilization and completion of site 33 remediation and adjacent conservation area invasive species removal. Added herbicide treatment to cleared areas to prevent regrowth and clearing of stormwater structures in wetland conservation area E free of charge.
- Collected additional fountain proposal.

4. Contract & Vendor Management

- Continually reviewing existing CDD vendor contracts to ensure performance and cooperation.
- Monitoring tennis court maintenance performance.
- Coordinated execution of release agreement for Bad Boar Trapping and Outfitters.
- Ensuring vendors meet district insurance requirements and collecting associated documentation.

5. Strategic Planning & District Administration

- Continued collaboration with amenities management and field operations regarding CDD related responsibilities.
- Updating and monitoring the Project-Reserve Tracker spreadsheet.
- Budget workshop meeting on April 2nd.
- Coordinating the updated Reserve Study.
- Collecting proposals/pricing for remediation items prior to PSH parcel conveyance.

Tab 10

HBCDD Task Management Tracker

Item	Project	Budget	Status/Notes	Entry Date	Estimated Completion Date	Completion
1	FY 26/25/24/23 Capital Reserve Account projects; NOT completed			4/8/2026		
	a. Phase 1 & Phase 2 (last repaint 2018)	\$144,517	Clubhouse, Outfitters, Youth center, Courts, Gates, Admiral point	4/8/2026		
	b. Irrigation system and pumps	\$150,000	Identify areas needing replacements and repairs	4/8/2026		
	c. Asphalt repave Phase 1, 2, & 3	\$995,601	Lighthouse drafting Road Priorities, Pedestrian, Speed Table improvements	4/8/2026		
	d. Sidewalk repairs	\$75,600	1 proposal received, 2 more pending.	4/8/2026		
	e. North/South Retention Ponds	\$200,000	MiraBay Working with State & County to assist with monies	4/8/2026		
	f. Landscape Enhancements & Improvements	\$353,018	Front Entrance, Clubhouse, Courts, approved (Hurricane & Frost)	4/8/2026		
	g. Pond Fountains	\$55,435	Collecting replacement proposals	4/8/2026		
	h. Club House AC Replacement	\$60,000	Proposal pending	4/8/2026		
	i. Seawall Cap sealed every 3 years to protect \$20 million investment for 50 year lifespan	\$291,038	Moved to 2028 in Reserve Study	4/8/2026		
2	Park Square Conveyance Agreement/Negotiation Plan		Compiling list of remediation items and costs	4/8/2026		
3	8.2 acres Rezoning as a future MiraBay Asset		In Concept planning	4/8/2026		
4	2027 Budget Workshop		Completed April 2, 2026	4/8/2026		
5	Townhalls Scheduled May/October		TBD	4/8/2026		
6	Community Stormwater Management Assessment Camera plan from Evergreen Fund		Contract signed, awaiting start date	4/8/2026		
7	Plan to replace trees from Hurricane Milton		District Coordinator and Field OPS developing list of priorities for consideration	4/8/2026		
8	Conduct After Action Review/Best Practices for Hurricane Milton		District Manager Task	4/8/2026		
9	Clubhouse Pool Area Landscape Refresh		Board approved	4/8/2026		
10	Best Price Roofing Demand Letter		Awaiting BPR Legal response	4/8/2026		
11	Envera Camera Equipment Status in community		DC Building List for Improvements	4/8/2026		
12	MiraBay IT Equipment/software Upgrade Proposal		IT Proposal for Backup capability, New FMX software (Maintenx)	4/8/2026		
13	Renew HCSO & HBCDD Traffic Control Jurisdiction Agreement		TBP	4/8/2026		
14	Main Gates & US 41 Paver replacement Project		Add Project to Capital Reserve Study	4/8/2026		
15	New software for Tennis & Pickleball Court reservation management		Amenity management recommendation	4/8/2026		
16	Improve No Wake Zone with Buoys and Idle Speed signage in community		Evergreen fund	4/8/2026		
17	Turnstile Installation improving security for Basketball and Tennis gates		increase security and resident access	4/8/2026		
18	Boat Lift Dredging Plan from Evergreen Fund	\$43,000	Engineer handling bathymetric study proposal	4/8/2026		
19	Gate Strikes ledger.		Statistics	4/8/2026		
20	Power wash map		Field OPS priorities and Schedule for Community	4/8/2026		

Habor Bay CDD - Project Tracker

Item	Community-Location	Project	Who is handling?	Status/Notes	Entry Date	Estimated Completio	Completion Date
		mulch installation - US41 Berm	Kims	done	1/9/2026	1/9/2026	1/15/2026
		Dead Palm Removal - 626 Manns Harbor	Kims	done	12/23/2025	1/15/2026	1/15/2026
		Dead Palm Removal - Ibisview	Kims	done	12/23/2025	1/15/2026	1/15/2026
		Removal of 50' Bismarkia Palm – Lee Te Kim Park	Kims	done	12/23/2025	1/15/2026	1/15/2026
		Removal of Dead Palm – Mirabay Blvd. next to LTK Park	Kims	done	12/23/2025	1/15/2026	1/15/2026
		Removal of 50' Medjool Palm – Clubhouse	Kims	done	12/23/2025	1/15/2026	1/15/2026
		Manns harbor bridge palms	Kims	done	1/16/2026	2/15/2026	1/29/2026
		Wolf Creek Park overgrowth	kims	done	1/16/2026	2/15/2026	1/29/2026
		admiral pointe conservation cutback	kims	done	1/16/2026	2/15/2026	1/29/2026
		Tennis Court Resurfacing	Clay	executed, circulated. Work on feb 9	1/13/2026	2/13/2026	2/17/2026
		Tennis court maintenance contract	Clay	Executed	1/16/2026	2/16/2026	2/17/2026
Mirabay Blvd		Radar Speed Sign	Field/DC	installed	2/6/2026	3/1/2026	3/2/2026
Playgrounds		Playground Mulch - 3 playbays	DC	Completed	2/2/2026	3/19/2026	3/9/2026
Marisol Pointe		Remediation Proposals	DC	Received Landscaping/Aquatics proposals	3/10/2026	3/10/2026	3/10/2026
Caffrey Pl		Caffrey Pl seawall weed treatment	DC	Completed - imazapyr can take weeks to kil	3/2/2026	3/18/2026	3/20/2026
Pond 2		north fountain warranty repairs	DC/field	Fountain back up and running	1/16/2026	TBD	3/16/2026
Various locations		Reserve Study Update	DC/Chairman	Updated reserve study received	3/1/2026	4/2/2026	3/23/2026

Vendor / Contractor	Service Category	Scope of Service	Contract Start Date	Contract End / Renewal Date	Auto Renew (Y/N)	Monthly Cost	Annual Cost	Payment Frequency	Invoice Due Date	Assigned District Contact	Vendor Contact Name	Vendor Phone/Email	Status (Active/Pending/Expired)	Notes / Action Items
Rizetta District Manager	District Management	District Management Services						Monthly					Active	
Legal Services	Legal	District Legal Counsel						Monthly/As Needed					Active	
Lighthouse Engineering	Engineering	Engineering Services						Monthly/As Needed					Active	
Accounting Services	Finance	District Accounting Services						Monthly					Active	
Premier Technologies	IT	IT Support / Technology						Monthly					Active	
Envera Security Operations	Security	Gate/Access Control Monitoring						Monthly					Active	
TECO Utility lease	Utilities	Utility Lease Agreement						Monthly					Active	
Bluewater Aquatics	Aquatics	Pool Maintenance / Chemical Service						Weekly/Monthly					Active	
Turf Management	Grounds	Turf / Irrigation / Grounds Maintenance						Monthly					Active	
Landscaping	Grounds	Landscaping Contract						Monthly					Active	
Water metering	Utilities	Water Meter Reading / Monitoring						Monthly					Active	
Tennis court maintenance	Amenities	Tennis Court Cleaning / Repair						Monthly/Quarterly					Active	
Bad boar trapping	Wildlife	Hog Trapping / Wildlife Control						Monthly/As Needed					Active	
Core empire power washing	Maintenance	Pressure Washing						Monthly/Quarterly					Active	
USA services of FL street swee	Roads	Street Sweeping						Monthly					Active	
Cheney brothers	Food & Beverage	Food Vendor Supply						Weekly					Active	
Paychex	Payroll	Payroll / HR Processing						Biweekly/Monthly					Active	
Clover	POS System	POS Processing / Equipment Fees						Monthly					Active	
Elevator maintenance & perm	Safety/Facilities	Elevator Maintenance & Permit Renewal						Annual					Active	Track permit expiration
Pest control	Facilities	Pest Prevention Services						Monthly					Active	
Phenomenal Fitness Equipme	Fitness	Fitness Equipment Maintenance						Monthly/Quarterly					Active	
Harbor Patrol HCSO	Security	Harbor Patrol / Sheriff Support						Monthly/As Needed					Active	

Tab 11



UPCOMING DATES TO REMEMBER

- **Next Regular/ FY 26/27 Proposed Budget Meeting:** May 21, 2026 @ 6:00 PM
- **Next Election:** The term expires for Michael Rodriguez Seat 1, Daniel Leventry Seat 2, Dean Walters Seat 3 and are scheduled for the General Election on November 3, 2026. The qualifying period for Board candidates will be from Noon June 8, 2026 to Noon June 12, 2026. Newly elected Board members for each seat will have a 4-year term and assume office on the second Tuesday following the General Election on November 3, 2026.

District
Manager's
Report

April 16

2026

H
A
R
B
O
R

B
A
Y

C
D
D

<u>FINANCIAL SUMMARY</u>	<u>2/28/2026</u>
General Fund Cash & Investment Balance:	\$2,981,839
Reserve Fund Cash & Investment Balance:	\$2,923,961
Debt Service Fund Investment Balance:	\$2,781,046
Mirabay Fund Cash:	\$110,593
Evergreen Fund Cash & Investment Balance:	\$219,564
Total Cash and Investment Balances:	\$9,017,003
General Fund Expense Variance: \$172,681	Under Budget
Reserve Fund Expense Variance: \$324,656	Under Budget
Mirabay Fund Expense Variance: \$125,443	Under Budget
Evergreen Fund Expense Variance: \$30,949	Under Budget

Tab 12



Harbor Bay CDD / MiraBay Community
Chastity Kelly, General Manager
March 2026 Report

Operations Update – Board of Supervisors Summary

Operations are fully underway as we continue to elevate the resident experience with enhanced poolside service. We have successfully implemented a mobile outdoor bar on Saturdays and Sundays, which has increased engagement and added a resort-style element to weekend programming.

The Food & Beverage program is showing measurable improvement in both execution and offerings. Over the next several months, we will be expanding service to include weekend breakfast and the introduction of a structured dinner menu, further aligning our operations with a true hospitality-driven model.

In addition, we have started our comprehensive hurricane preparedness checklist to ensure operational readiness, safety, and continuity of services during the upcoming season.

I have also expanded my involvement into the Field Operations department, where efforts are currently focused on assessing current workflows, implementing structure, and establishing clear operational standards to improve efficiency and accountability across the department.

Facility & Service Updates

- Paint & Sip has been a huge hit with the community
 - Still working with Mabel for water Aerobics program
 - Staff will be conducting pontoon and kayak patrols of the lagoon to verify vessel registration stickers. This process will be completed by April 15.
 - Our Spring Break program went amazing, and we are gearing up for our summer program.
 - Mobil pool bar on Saturdays and Sundays for the Summer
 - Working with Mr. Kim and District coordinator assessing the community and where the problem areas are
 - Management has been working on the Amenities Rules and having our community adhere to them
-

Staff Development & Training

- We have been training our staff on Craft Cocktails and adding more drinks to our menu for the upcoming summer season.
 - GM & DOO will be attending CPO classes
 - Training our staff in our Hurricane preparedness
-

Operational Activity

With the arrival of warmer weather, resident activity and weekend pool attendance are increasing, and operations are adjusting staffing and services accordingly to accommodate the higher usage.

April Events

- Paint & Sip

- Easter Egg Hunt & Easter Brunch
- Build-A-Burger Night
- Kevin McCarthy Live Music

Club Programming

Friday evenings now feature themed buffet-style dinners with live music, including rotating themes such as:

- Tex-Mex Night
- Pasta Night
- Around the World
- Steak Night

These events continue to drive strong resident engagement.

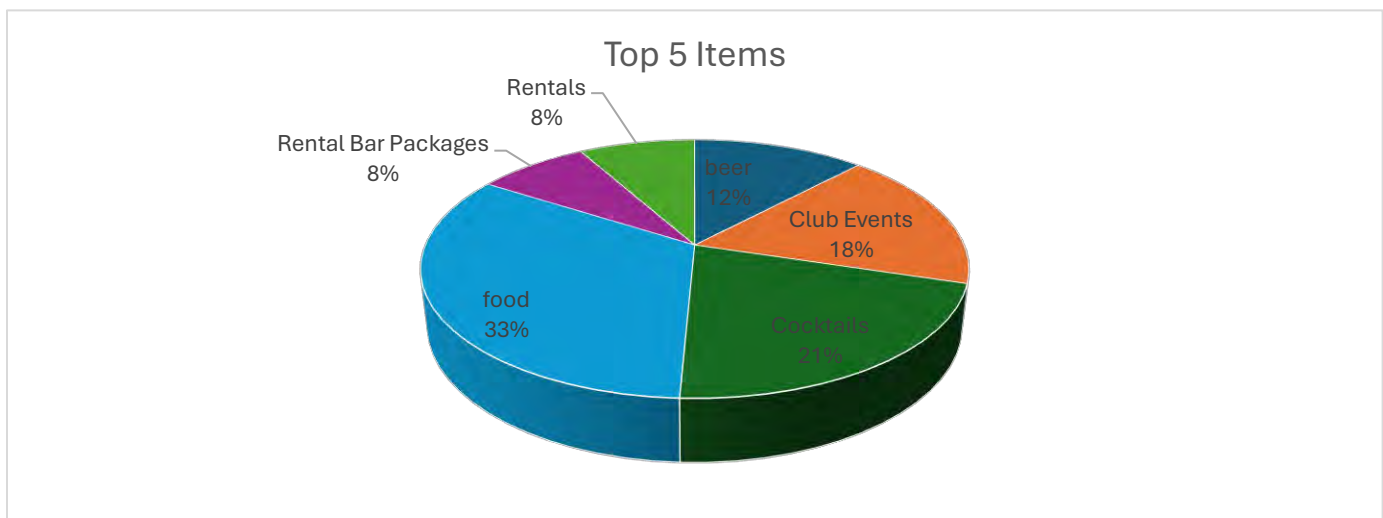
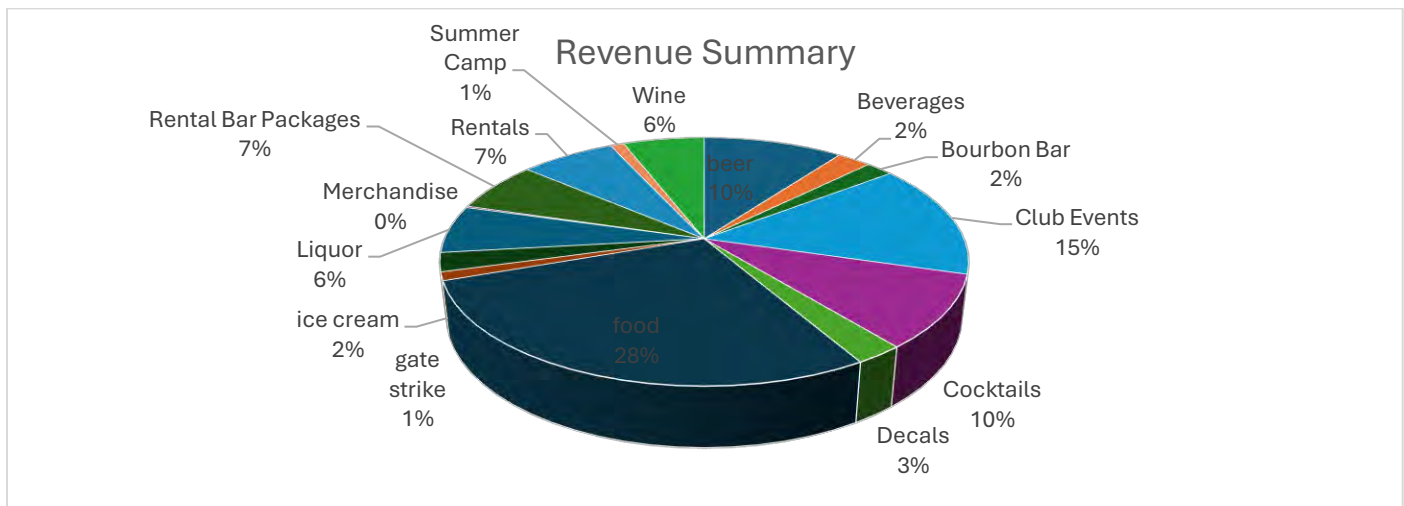

TAB 13

HARBOR BAY COMMUNITY DEVELOPMENT DISTRICT

TENNIS VENDOR AGREEMENT

This Vendor Agreement (“Agreement”) is entered into on this **17th day of March 2026**, by and between:

Harbor Bay Community Development District

A Florida Community Development District pursuant to Chapter 190, Florida Statutes (“CDD”)

and

Vendor Name: **Pirate Bay Athletics LLC**

Business Name (if applicable):

Address: **1950 Brickell Ave, Unit 103, Miami, FL 33129**

Phone: **305-890-9204** Email: **pedro.franco@piratebayathletics.com**

(“Vendor”)

1. PURPOSE

The purpose of this Agreement is to define the terms under which Vendor shall provide tennis-related services at the Harbor Bay CDD tennis facilities.

Vendor shall operate as an independent contractor and not as an employee, partner, or agent of the CDD.

2. SCOPE OF SERVICES

Vendor agrees to provide the following services:

- Private tennis lessons
- Group clinics
- Youth development programs
- Camps (seasonal and summer)
- Tournaments and special events
- Court instruction and programming support

All services must be pre-approved by the CDD or its designated representative.

Vendor shall submit a written program outline and schedule for approval prior to advertising or launching any program.

3. FACILITY USE

Vendor is granted non-exclusive use of the Harbor Bay CDD tennis courts and related amenities for approved programming.

Vendor agrees to:

- Adhere to court scheduling policies
- Yield courts to CDD-approved events as directed
- Maintain cleanliness of courts and surrounding areas
- Report maintenance concerns immediately

The CDD reserves the right to adjust court access due to maintenance, weather, or district events.

The CDD will not provide any equipment. The Vendor is responsible for providing their own equipment, including, but not limited to, tennis balls and tennis racquet. The CDD is not responsible for any stolen or lost items while using facilities by Vendor.

4. COMPENSATION & FEES

Compensation structure (check one or attach addendum):

Revenue Share: Vendor shall remit 10% of gross revenue collected from programs monthly.

Flat Monthly Fee: \$_____ per month.

Per-Clinic / Per-Program Fee Structure (see attached Schedule A).

Payment shall be due on or before the ___ day of each month for the previous month's services.

Vendor shall provide a monthly revenue report detailing:

- Program name
- Participant count

- Gross revenue
 - Net revenue (if applicable)
-

5. INSURANCE REQUIREMENTS

Vendor must maintain:

- General Liability Insurance (minimum \$1,000,000 per occurrence)
- Professional Liability Insurance
- Workers' Compensation (if applicable)

Harbor Bay Community Development District must be listed as an **Additional Insured** on a primary and non-contributory basis.

A Certificate of Insurance must be submitted prior to the start date and maintained throughout the Agreement term.

6. INDEPENDENT CONTRACTOR STATUS

Vendor is an independent contractor and is solely responsible for:

- Payroll taxes
- Employment taxes
- Background checks for staff
- Licensing requirements
- Compensation of assistants or subcontractors

No benefits, insurance, or employment protections shall be provided by the CDD.

7. BACKGROUND SCREENING

All Vendor staff, instructors, and assistants working on-site must:

- Pass a Level 2 background screening
- Comply with child safety policies
- Follow all CDD code of conduct standards

Proof of screening must be submitted upon request.

8. SAFETY & RISK MANAGEMENT

Vendor agrees to:

- Enforce proper tennis safety protocols
- Monitor weather conditions
- Supervise minors at all times
- Maintain first aid accessibility

The CDD shall not be responsible for injuries resulting from Vendor-led programming.

9. MARKETING & BRANDING

Vendor may promote programs, but:

- All marketing materials must be approved by CDD management prior to distribution
- CDD logo may not be altered or misused
- Vendor may not represent itself as the owner/operator of the tennis facility

All communication to residents must align with CDD branding standards.

10. TERM & TERMINATION

This Agreement shall begin on the **1st day of April 2026** and remain in effect for:

- One (1) Year
- Seasonal Term (Specify) _____
- Month-to-Month

Either party may terminate this Agreement with thirty (30) days written notice.

The CDD reserves the right to terminate immediately for:

- Breach of agreement
- Safety violations

- Failure to maintain insurance
 - Conduct detrimental to the community
-

11. INDEMNIFICATION

Vendor agrees to indemnify, defend, and hold harmless Harbor Bay CDD, its Board, agents, and employees from any claims, damages, liabilities, expense or legal actions (including attorney's fees) arising from Vendor operations.

12. VENDOR REPRESENTATION; COMPLIANCE WITH LAWS

Vendor represents and warrants that it has the experience and expertise to provide the scope of services.

Vendor shall comply with all:

- Federal laws
 - State of Florida laws
 - County regulations
 - Local safety ordinances
 - CDD rules, regulations and procedures
-

13. NON-EXCLUSIVITY

This Agreement does not grant Vendor exclusive rights to operate tennis programming unless specifically stated in writing.

14. DISPUTE RESOLUTION

Any disputes arising from this Agreement shall be governed by the laws of the State of Florida and venue shall be in Hillsborough County.

15. ENTIRE AGREEMENT

This Agreement constitutes the entire agreement between the parties and supersedes any prior verbal or written agreements.

16. MISCELLANEOUS

As a public entity, the CDD is subject to Florida public records law pursuant to Chapter 119, Florida Statutes.

The CDD is a public entity that is subject to the E-Verify requirements as set forth in Section 448.095, Florida Statutes, and that the provisions of Section 448.095, F.S., apply to this vendor agreement.

Vendor may not assign this Agreement without the prior written approval of the District. Any assignments attempted to be made by Vendor without the prior written approval of the District are void.

SIGNATURES

Harbor Bay Community Development District

By: _____

Name: _____

Title: _____

Date: _____

Vendor
Signature: 

Printed Name: **Pedro Franco**

Date: **03/17/2026**

TAB 14



Harbor Bay CDD / MiraBay Community
Field Operations Report | Chastity Kelly General Manager
March 2026 Report

Operations Update – Board of Supervisors Summary

Field Operations Summary – March

Field Operations made meaningful progress in March, with a strong focus on supporting capital improvements, strengthening operational discipline, and advancing team standards.

- **Roof Construction Support:** Construction on the clubhouse roof has officially begun. The Field Operations team is actively supporting the project by coordinating access, assisting vendors as needed, and ensuring minimal disruption to daily operations and the resident experience.
- **Daily Operations & Pool Readiness:** Morning priorities have been restructured to ensure both pools are fully prepared and operational for the start of each day. This includes cleanliness, safety checks, equipment functionality, and overall presentation to meet resort-style expectations.
- **Operational Efficiency:** A continued focus has been placed on improving the timeliness and consistency of daily task execution. The team is strengthening accountability around daily checklists, work orders, and preventative maintenance to create a more disciplined and efficient workflow.
- **Team Development & Compliance:** We are in the process of getting all Field Operations technicians **CPO (Certified Pool Operator)** certified. This initiative will enhance pool safety, ensure compliance, and elevate aquatics operations across the community.
- **Hurricane Preparedness:** In collaboration with the General Manager, the team is finalizing a comprehensive Hurricane Preparedness Checklist to ensure readiness for the upcoming season, including pre-storm protocols and post-storm recovery planning.
- **Waterway Compliance & Oversight:** Field Operations has initiated on-water inspections to verify boat registrations and ensure adherence to community guidelines, reinforcing safety and proper use of waterways.
- **Seasonal Demand Adjustments:** With the arrival of warmer weather, resident activity and weekend pool attendance have increased. Operations are proactively adjusting staffing levels and service support to accommodate higher usage while maintaining service standards.

Overall, March reflects continued progress toward structured, standards-driven operations with a strong emphasis on readiness, safety, and elevated resident experience.

Facility & Service Updates

- Dog station 2/week service - Fitness room AC repaired - Monument bases on Ibisview repaired and painted - Pickleball courts washed twice before tournament - Pickleball court edging installed for excess clay control - New washing machine installed - Handicap swing provided and installed at Wolf Creek Park - Leaf clean up around clubhouse - Speed limit post hit, reinstalled and concreted in Seacrest - Speed radars adjusted and provided larger limit signs - 3 wall mounted fans for Café installed - New pool shower handle busted and repaired - No parking overnight signs installed in Seacrest - Pathway light damaged and repaired - Admiral point AC coils cleaned - New pool signs provided for Admiral Point - Wind screen damage repaired - Promenade bulletin board repaired - Pond signs concreted and straightened - Men's urinal repaired - New cylinder locks for café storage and kegerator - Pool tiles cleaned - Bathroom door handle broken and repaired - Playground post broken and repaired - H.O.A dropbox installed at Admiral Point - Zero entry sprinklers cleaned and repaired - Exterior clubhouse lightbulbs replaced - Back gate to boat latch broke and repaired - Lagoon room door adjusted - Basketball court nets installed and bases repaired - Basketball front gate and fence repaired - Clubhouse signs broken and repaired - Broken clubhouse door handle replaced

FMX REPORTS:

We have had no FMX reports from the community for the month of March

TAB 15

MINUTES OF MEETING

Each person who decides to appeal any decision made by the Board with respect to any matter considered at the meeting is advised that the person may need to ensure that a verbatim record of the proceedings is made, including the testimony and evidence upon which such appeal is to be based.

HARBOR BAY COMMUNITY DEVELOPMENT DISTRICT

The Regular Meeting of the Board of Supervisors of Harbor Bay Community Development District was held on Thursday, March 19, 2026, 6:00 p.m. at the MiraBay Clubhouse Lagoon Room located at 107 Manns Harbor Drive, Apollo Beach, FL 33572.

Present and constituting a quorum:

- Steven Finley Board Supervisor, Chair
Dean Walters Board of Supervisors, Vice Chair
Daniel Leventry Board Supervisor, Assistant Secretary
Michael Rodriguez Board Supervisor, Assistant Secretary (via conference call)
Tim Nargi Board Supervisor, Assistant Secretary (via conference call)

Also present were:

- Lynn Hayes District Manager, Rizzetta & Company
Andrew Cohen District Counsel, Persson, Cohen, Mooney
Amy Palmer District Engineer, Lighthouse Engineering, Inc. (via conference call)
Chastity Kelly Director of Operations, Mirabay Clubhouse
Clay Wright CDD District Coordinator
Chris Thompson Representative, Blue Water Aquatics
Audience Present

FIRST ORDER OF BUSINESS

Call to Order

Mr. Hayes called the meeting to order, conducted rollcall, and verified that a quorum was present. The meeting commenced at 6:00 p.m.

SECOND ORDER OF BUSINESS

Pledge of Allegiance

50
51 The Pledge of Allegiance was recited.

52
53 Mr. Finley requested a motion for Board Supervisor Michael Rodriguez to appear
54 virtually and have voting privileges. No second was made, and the motion failed.
55

56 On a Motion by Mr. Leventry, seconded by Mr. Walters, with all in favor, the Board of
57 Supervisors approved the request for Board Supervisor Tim Nargi to appear virtually and
58 have voting privileges for the Harbor Bay Community Development District Community
59 Development District.

60
61 **THIRD ORDER OF BUSINESS**

Audience Comments

62
63 The Board of Supervisors fielded questions and comments during audience
64 comments. Audience comments were regarding dedicated amenities for Marisol Point
65 including a gate and the speeding of construction vehicles within Marisol Point. An audience
66 member raised concerns about the Park Square conveyance not on the agenda and the
67 lack of progress. An audience member requested an update on reclaiming Signet Drive
68 from Hillsborough County. An audience member provided detailed critique of the vendor
69 invoice and payment process.

70
71 **FOURTH ORDER OF BUSINESS**

**Consideration of Seacrest Stormwater
Lid Proposals (under separate cover)**

72
73
74 This item was reclassified as a maintenance task within General Manager's spending
75 authority and is proceeding.

76
77 **FIFTH ORDER OF BUSINESS**

**Consideration of Sidewalk Grinding &
Replacement**

78
79
80 Mr. Wright has requested proposals from three vendors, only one proposal received
81 to date. The Board of Supervisors will wait to review all three proposals.

82
83 **SIXTH ORDER OF BUSINESS**

**Discussion on Hurricane
Preparedness and After Review**

84
85
86 Mr. Leventry wants to dedicate 30 minutes at the April 16, 2026, CDD meeting and
87 asked all Board Supervisors to bring 3 suggestions. The Board of Supervisors review with
88 District Staff BOS/CDD procedures/disaster plan for Hurricane Preparedness and After-
89 Action Plans.

90
91
92
93
94
95 **SEVENTH ORDER OF BUSINESS**

Consideration of Pet Waste Proposals

96

97 On a Motion by Mr. Walters, seconded by Mr. Leventry, with two in favor, and one Mr.
98 Finley opposed, the Board of Supervisors the motion to proceed with Pet Maintenance
99 proposal from Stan Stark and authorized the Chair to execute agreement subject to staff
100 approval with 30-day termination with convenience, for the Harbor Bay Community
101 Development District.

102
103 **EIGHTH ORDER OF BUSINESS**

**Discussion of RFP for District
Management**

104
105
106 Mr. Finley presented information from previous meeting minutes and Board of
107 Supervisors regarding this topic. A discussion ensued and Mr. Finley and Mr. Nargi said no
108 to RFP for District Management. Mr. Leventry and Mr. Walters said yest to RFP for District
109 Management. Mr. Cohen explained that there is no statutory requirement to issue an RFP
110 for District Management services, but it may be pursued as best practice. Mr. Walters asked
111 if Rizzetta would terminate their contract if the district does an RFP for District Management
112 services. Mr. Hayes said he would speak with Senior Management and would circulate the
113 answer to the Board of Supervisors. This item was tabled and will be added to the April 16,
114 2026 CDD meeting agenda.

115
116 **NINTH ORDER OF BUSINESS**

Staff Reports

117
118 **A. Aquatic Report**

119
120 **i. Blue Water Fountain Report**

121 Mr. Thompson presented the fountain report.

122
123 On a Motion by Mr. Leventry, seconded by Mr. Nargi, with two in favor, and two opposed
124 (Mr. Finley and Mr. Walters opposed, the Board of Supervisors approved Blue Water
125 proposal for \$29,870.72 for 2 Air Max fountain systems for north and south ponds, for the
126 Harbor Bay Community Development District. Motion failed.

127
128 On a Motion by Mr. Nargi, seconded by Mr. Leventry, with all in favor, the Board of
129 Supervisors approved Blue Water proposal for \$29,870.72 for 2 Air Max fountain systems
130 for north and south ponds, for the Harbor Bay Community Development District.

131
132 On a Motion by Mr. Leventry, seconded by Mr. Walters, with all in favor, the Board of
133 Supervisors rescinded previous motion to approved Blue Water proposal for \$29,870.72
134 for 2 Air Max fountain systems for north and south ponds, for the Harbor Bay Community
135 Development District.

136
137
138
139
140
141 **ii. Blue Water Aquatic Report**

142 Mr. Thompson presented the aquatic report.

144 iii. Consideration of Pond 33 Debris Removal Proposal
145

146 On a Motion by Mr. Finley, seconded by Mr. Leventry, with all in favor, the Board of
147 Supervisors approved Steadfast Alliance proposal in the amount of \$5,780.00, subject to
148 District Counsel prepare final form agreement and authorizes the Chair to execute the
149 agreement, for the Harbor Bay Community Development District.

150
151 iv. Consideration of CSDI Shell Cove Wetland Removal of Brazillan Pepper
152 Trees Proposal
153

154 On a Motion by Mr. Finley, seconded by Mr. Leventry, with all in favor, the Board of
155 Supervisors approved Steadfast Alliance proposal in the amount of \$14,910.00, subject
156 to District Counsel prepare final form agreement and authorizes the Chair to execute the
157 agreement, for the Harbor Bay Community Development District.

158
159 **B. Presentation of LT Kim Landscape Reports**
160

161 Mr. Walters told the Board Supervisors that they approved to replace palm from
162 his house to donate to the CDD, but this did not happen and he decided to keep
163 it.
164

165 **8.2 Acre Parcel Entitlement Update**
166

167 Mr. Finley stated that a land use attorney cancelled their meeting. This item
168 was tabled to the April 16, 2026 CDD meeting.
169

170 **C. District Counsel**
171

172 Mr. Cohen stated the roofing contract is fully executed and a pre-construction
173 meeting is scheduled for the week of March 23, 2026. Mr. Cohen stated that
174 the Best Price roofing litigation counsel has until March 24, 2026 to respond
175 and noted their claims are without basis as the district always had a 30-day
176 termination for convenience clause. The Mor Sports settlement is completed
177 and they have fixed the pickleball courts maintenance issues. Mr. Cohen
178 provided an update on Park Square negotiations, and the district is assembling
179 costs to respond to Park Square. Mr. Cohen provided a legislative update
180 highlighting three bills affecting CDD's (advertising, Sovereign immunity limits,
181 supervisor recall) that are with the Governor. Mr. Cohen recommended
182 aligning Kim Landscape two separate contracts to terminate on September 30.
183 He advised that due to contract value the district will be required to go through
184 a formal RFP process for renewal, likely in June. A Board Supervisor stressed
185 communicating this to the vendor as a legal requirement to avoid them being
186 offended. Mr. Cohen reminded the Board Supervisors against using social
187 media for CDD business to avoid Sunshine Law issues.
188

189 **D. District Engineer**
190

191 Ms. Palmer stated the stormwater cameras project will start May 2026.

192
193
194
195
196
197
198
199
200
201
202
203
204
205
206
207
208
209
210
211
212
213
214
215
216
217
218
219
220
221
222
223
224
225
226
227
228
229
230
231
232
233
234
235
236
237
238
239

i. Consideration of Dock & Lift Applications

On a Motion by Mr. Finley, seconded by Mr. Walters, with all in favor, the Board of Supervisors approved 1074 Signet Drive Dock & Lift application subject to TPA approval and construction monitoring, for the Harbor Bay Community Development District.

A homeowner at 5718 Tybee installed a jet ski lift in addition to a boat lift, again district policy. District Counsel was directed to prepare a demand letter to them for removal.

On a Motion by Mr. Leventry, seconded by Mr. Walters, with all in favor, the Board of Supervisors approved 5718 Tybee standard Dock & Lift application, for the Harbor Bay Community Development District.

ii. Discussion of 1090 Signet Drive Jet Ski Lift Application

District Counsel was directed to provide demand letter to homeowners at 1090 Signet Drive to remove jet ski lift.

iii. Consideration of Roadway RFP Scope

A draft shell and timeline were presented substantive scope will be provided by District Engineer by April with a June release.

iv. Discussion of Marisol Pointe Seawall

Spraying and treatment to remove weeds on wall will be completed on March 20, 2026, by Blue Water.

v. Discussion of Bathymetric Study Proposal

A discussion ensued, the district will use Evergreen funds to pay for this expense. District Engineer will get revised proposal and 2 more with scope to include dredge volume and provide to District Manager for the April 16, 2026, CDD meeting agenda. Board of Supervisors would like Park Square to pay half of this cost.

E. District Coordinator

Mr. Wright stated the playground mulch is installed, and the final invoice was \$5,550 under initial quote. The pool slide stairs replacement contract form is near completion, insurance language is being finalized. The fiberglass treads lead time is 8 weeks, contract allows 52 business days from execution, the slide remains closed for safety.

240 i. Presentation of Project/Reserve Contract/Tracker
241
242 Mr. Wright reviewed the Project/Reserve Contract/Tracker with the Board
243 of Supervisors and invited them to add items.
244

245 **F. District Manager**
246

247 i. Presentation of District Manager Report
248
249 The District Manager confirmed April 2, 2026, at 6:00 p.m. to conduct a FY
250 26/27 budget workshop and April 16, 2026, at 6:00 p.m. will be the next
251 CDD meeting.
252

253 Mr. Hayes stated the General Election qualifying period will be June 8,
254 2026, Noon to June 12, 2026, Noon, terms are for four (4) years, any
255 questions should be directed to Hillsborough County Supervisor of
256 Elections.
257

258 ii. Discussion of Vendor Invoice Process & Payment Instructions Summary
259
260 Mr. Finley presented an overview of this process.
261

262 **G. Onsite Manager Reports**
263

264 i. Director of Operations Report
265
266 Ms. Kelly presented her report. Ms. Kelly is temporarily overseeing Field
267 Operations and is recruiting for a Field Operations Manager. The Pool Heater
268 repair is covered under warranty. Wildlife trapping is deferred to next month,
269 and invoicing/settlement issues are currently being resolved.
270

271
272
273
274
275
276
277

278 ii. Field Operations Manager Report
279
280 Ms. Kelly presented the Field Operations report. The Board of Supervisors
281 requested mapping/prioritization for sidewalks/curbing and pressure
282 washing. Field Operations to coordinate mapping with District Engineer and
283 District Counsel support and bring a prioritized plan for the Board of
284 Supervisors to review.
285

288
289
290
291
292

Mr. Hayes presented the Meeting Minutes of Board of Supervisors Regular Meeting held on February 19, 2026, the Operations & Maintenance Expenditures for January 2026, and the January 2026 Financial Statement.

On a Motion by Mr. Finley, seconded by Mr. Leventry, with all in favor, the Board of Supervisors approved the Regular Meeting Minutes of Board of Supervisors held on February 19, 2026, as amended, the January 2026 Financial Statements and ratified the January 2026 Operation & Maintenance Expenditures, Harbor Bay \$290,947.84, Evergreen \$618.30 and Mira Bay \$18,258.66, for the Harbor Bay Community Development District.

293
294
295
296
297
298
299
300

ELEVENTH ORDER OF BUSINESS

Audience Comments On Non-Agenda Items

The Board of Supervisors fielded questions and comments during audience comments on non-related agenda items about the following. Signet Drive ingress/egress and gate, questions regarding how invoices are processed and raised questions about specific landscaping invoices and monthly trimming compliance.

301
302
303

TWELFTH ORDER OF BUSINESS

Supervisor Requests

Mr. Finley stated that ice cream trucks are permitted due to road being public and requested patience from the community regarding the roofing contractor and the pool stairs.

306
307
308
309

Mr. Walters reminded the Board Supervisors that Ethics training is to be completed and reported on Form 1 that is due July 1.

310
311
312
313
314
315
316
317

Mr. Leventry inquired about a late fee on a Frontier Invoice and requested that a credit be applied. He also inquired about the status of payment reimbursement from Board Supervisor Michael Rodriguez and would like a copy of the revised paper from Steven Finley regarding Master Historical Record regarding Hurricane Milton.

318
319

THIRTEENTH ORDER OF BUSINESS

Adjournment

320
321
322

On a Motion by Mr. Leventry, seconded by Mr. Finley, with all in favor, the Board of Supervisors adjourned the Harbor Bay Community Development District Meeting at 9:11 p.m.

323
324
325
326
327
328

Tab 16

HARBOR BAY COMMUNITY DEVELOPMENT DISTRICT

DISTRICT OFFICE · WESLEY CHAPEL, FLORIDA (239) 936-0913
MAILING ADDRESS · 3434 COLWELL AVENUE, SUITE 200 · TAMPA, FLORIDA 33614

Operation and Maintenance Expenditures February 2026 For Board Approval

Attached please find the check register listing the Operation and Maintenance expenditures paid from February 1, 2026 through February 28, 2026. This does not include expenditures previously approved by the Board.

The total items being presented: **\$228,987.52**

Approval of Expenditures:

_____ Chairperson

_____ Vice Chairperson

_____ Assistant Secretary

Harbor Bay Community Development District

Paid Operation & Maintenance Expenditures

February 1, 2026 Through February 28, 2026

<u>Vendor Name</u>	<u>Check Number</u>	<u>Invoice Number</u>	<u>Invoice Description</u>	<u>Invoice Amount</u>
All Traffic Solutions Inc	300259	1818957	Speed Display and Battery 02/26	\$ 5,314.92
Aquacal Autopilot Inc.	300261	INV-WO0070778	Repairs 09/25	\$ 502.50
Blue Water Aquatics, Inc.	300262	34958	Aquatic Maintenance 01/26	\$ 3,640.00
Charter Communications	20260224-1	2380453020526-020526	5248 Admiral Pointe Dr 02/26	\$ 215.88
Core Empire, LLC	300246	333	Pressure wash 01/26	\$ 2,200.00
Culligan Water Conditioning	300254	5140655	Ice Delivery 01/26	\$ 69.00
Custom Reserves LLC	300270	R82.26	Reserve Study - 50% Deposit 02/26	\$ 2,350.00
Daniel Leventry	300249	DL011526	Board of Supervisor Meeting 01/15	\$ 200.00
Daniel Leventry	300271	DL021926	Board of Supervisor Meeting 02/19	\$ 200.00
Dean Walters	300250	DW011526	Board of Supervisor Meeting 01/15	\$ 200.00
Dean Walters	300272	DW021926	Board of Supervisor Meeting 02/19	\$ 200.00
DEX Imaging, LLC	300247	AR14555323	Billing Period 01/01/26-03/31/26	\$ 329.74
DirecTV	20260226-1	057414714X260211	107 Manns Harbor 02/26	\$ 334.29

Harbor Bay Community Development District

Paid Operation & Maintenance Expenditures

February 1, 2026 Through February 28, 2026

<u>Vendor Name</u>	<u>Check Number</u>	<u>Invoice Number</u>	<u>Invoice Description</u>	<u>Invoice Amount</u>
Envera Systems	300255	765034	Video Monitoring 03/26	\$ 18,175.81
Envera Systems	300263	765741	Video Monitoring 03/26	\$ 37.08
Frontier Communications of FL	300258	23910000510317205-012526	Phone/Internet/Cable 02/26	\$ 2,736.34
Gas South	20260220-1	1507180292-013026	Utility Services 01/26	\$ 563.37
GoTo Communications, Inc.	300233	IN7104936766	Monthly Service 02/01/28-02/28/26	\$ 236.91
Hanley Pools, LLC	300264	1307	Replace Sand Filters 02/26	\$ 1,250.00
Hecker Construction Company	300256	7882	Seawall Repair 02/26	\$ 2,500.00
Hillsborough County BOCC	20260203-1	1779718759-012126	5248 Admiral Pointe 12/25	\$ 445.39
Hillsborough County BOCC	20260203-1	4432900000-012126	751 Manns Harbor Dr 12/25	\$ 134.87
Hillsborough County BOCC	20260203-1	5432900000-012126	5325 Fishersound Ln 12/25	\$ 235.28
Hillsborough County BOCC	20260203-1	6542900000-012126	5231 Point Harbor Ln 12/25	\$ 85.52
Hillsborough County BOCC	20260203-1	7788800000-012126	736 Manns Harbor Dr 12/25	\$ 459.00
Hillsborough County BOCC	20260203-1	9406800000-012126	107 Manns Harbor Dr 12/25	\$ 3,358.64

Harbor Bay Community Development District

Paid Operation & Maintenance Expenditures

February 1, 2026 Through February 28, 2026

<u>Vendor Name</u>	<u>Check Number</u>	<u>Invoice Number</u>	<u>Invoice Description</u>	<u>Invoice Amount</u>
Lee Te Kim Lawn Care & Nursery	300234	FEB 06853	Palm Tree Treatment 02/26	\$ 6,174.00
Lee Te Kim Lawn Care & Nursery	300234	JAN 06846	Irrigation Repairs 01/26	\$ 7,695.03
Lee Te Kim Lawn Care & Nursery	300231	JAN 06847	Landscape Maintenance 01/26	\$ 41,166.66
Lee Te Kim Lawn Care & Nursery	300231	JAN 06848	Water Use Permit 01/26	\$ 500.00
Lee Te Kim Lawn Care & Nursery	300231	JAN 06849	Turfgrass Maintenance 01/26	\$ 23,601.67
Lee Te Kim Lawn Care & Nursery	300231	JAN 06850	Irrigation Maintenance 01/26	\$ 5,166.67
Lee Te Kim Lawn Care & Nursery	300231	JAN 06851	Maintenance - Park Square 01/26	\$ 15,000.00
Lighthouse Engineering Inc.	300235	33	Engineering Services 01/26	\$ 5,725.00
Main Gate Enterprises, Inc.	300236	37055	Service Call 01/26	\$ 225.00
Meredith Shreve	300265	021726 Shreve	Reimbursement Decorations 02/26	\$ 110.11
Miguel Rodriguez	300251	013126 Rodriguez	Ethics Course 12/25	\$ 79.00
Miguel Rodriguez	300251	MR011526	Board of Supervisor Meeting 01/15	\$ 200.00
Miguel Rodriguez	300273	MR021926	Board of Supervisor Meeting 02/19	\$ 200.00

Harbor Bay Community Development District

Paid Operation & Maintenance Expenditures

February 1, 2026 Through February 28, 2026

<u>Vendor Name</u>	<u>Check Number</u>	<u>Invoice Number</u>	<u>Invoice Description</u>	<u>Invoice Amount</u>
Oski Enterprises Inc	300242	INVp-9817-a	MB Signage - Balance 01/26	\$ 1,703.95
Persson, Cohen & Mooney, P.A.	300266	6694	Legal Services 01/26	\$ 20,055.00
Phenomenal Exercise Equipment	300237	246908	Maintenance 01/26	\$ 145.00
Phenomenal Exercise Equipment	300243	246937	Maintenance 02/26	\$ 150.00
Phenomenal Exercise Equipment	300267	246976	Maintenance 02/26	\$ 145.00
Republic Services	20280206-1	0696-001325545	Pickup Services 02/26	\$ 1,448.20
Rizzetta & Company, Inc.	300232	INV0000106713	Accounting Services 02/26	\$ 15,713.60
S & W Refrigeration, LLC	300257	84393	Service Call/Replacement 06/25	\$ 536.83
S & W Refrigeration, LLC	300257	86499	Installation of Water Filter 12/24	\$ 5,987.30
Schindler Elevator Corporation	300238	4607373273	Maintenance 02/26	\$ 263.01
Spectrum	20260217-1	2.38945E+12	107 Manns Harbor Dr 02/26	\$ 318.00
Steve Finley	300252	SF011526	Board of Supervisor Meeting 01/15	\$ 200.00
Steve Finley	300274	SF021926	Board of Supervisor Meeting 02/19	\$ 200.00

Harbor Bay Community Development District

Paid Operation & Maintenance Expenditures

February 1, 2026 Through February 28, 2026

<u>Vendor Name</u>	<u>Check Number</u>	<u>Invoice Number</u>	<u>Invoice Description</u>	<u>Invoice Amount</u>
TECO	20260220-2	211009424139-012926	Admiral Pointe - Utility Service 01/26	\$ 88.07
TECO	20260220-2	211009424568-012926	Admiral Pointe - Utility Service 01/26	\$ 1,129.12
TECO	20260220-2	211009425011-012926	Utility Services 01/26	\$ 54.82
TECO	20260220-2	211009425268-012926	Utility Services 01/26	\$ 352.75
TECO	20260220-2	221006323390-012926	Utility Services 01/26	\$ 152.85
TECO	20260220-2	221008458756-012926	Street Lights 01/26	\$ 11,529.74
TECO	20260224-2	311000030115-020526	Utility Services 01/26	\$ 10,546.34
Terminix	300248	467454721	Pest Control 12/25	\$ 781.49
Terminix	300248	468447476	Pest Control 01/26	\$ 781.49
Timothy Nargi	300253	013126 Nargi	Ethics Course 12/25	\$ 79.00
Timothy Nargi	300253	TN011526	Board of Supervisor Meeting 01/15	\$ 200.00
Timothy Nargi	300275	TN021926	Board of Supervisor Meeting 02/19	\$ 200.00
Triangle Pool Service	300268	011544-82	Chlorine 02/26	\$ 452.50

Harbor Bay Community Development District

Paid Operation & Maintenance Expenditures

February 1, 2026 Through February 28, 2026

<u>Vendor Name</u>	<u>Check Number</u>	<u>Invoice Number</u>	<u>Invoice Description</u>	<u>Invoice Amount</u>
Triangle Pool Service	300268	011544-84	Chlorine & Sulfuric Acid 02/26	\$ 355.00
Triangle Pool Service	300239	321834	Chlorine & Sulfuric Acid 01/26	\$ 360.22
Triangle Pool Service	300268	357655	Chlorine 02/26	\$ 270.00
Triangle Pool Service	300268	8529868157	Chlorine 02/26	\$ 737.50
USA Services of Florida, LLC	300240	FL12284080	Broom Sweeping - Mira Bay 01/26	\$ 1,100.48
USA Services of Florida, LLC	300269	FL12284461	Sweeping - Mira Bay 02/26	\$ 1,078.66
Wells Fargo Vendor Financial	300241	5037509498	Contract 450-0078530-000 02/26	\$ <u>53.92</u>
Report Total				\$ <u>228,987.52</u>



A TAPCO BRAND

5100 West Brown Deer Rd
Brown Deer, WI 53223
United States of America
Phone No.:800-236-0112
E-Mail: customerservice@tapconet.com

For ACH Delivery
Account Name: Traffic and Parking Control Co., LLC
Account Number: 706908665
Bank Routing No.: 075000019
Remittance Address:
PO Box 736881, Chicago, IL 60673-6881

SALES INVOICE

DATE

2/16/2026

INVOICE NO.

1818957

CUSTOMER NO.

C119726

Page: 1

[Click Here to Pay Online](#)

BILL TO

Harbor Bay CDD (FL)
C/O Rizzetta & Company
Tampa, FL 33614
United States of America

SHIP TO

Harbor Bay CDD (FL)
Daniel Leventry
107 Manns Harbor Drive
Apollo Beach, FL 33572
United States of America

P.O. NO.	SHIP VIA	Order Number	SALESPERSON	DUE DATE	TERMS
NONE	QUOTE COMP ABF, STANDARD	SO-048338	Conner Howell	3/18/2026	Net 30 DAYS

Item/Description	U/M	Order Qty	Quantity	Unit Price	Total Price
3200-0000 Freight Sales		1	1	230.00	230.00
4000863 Shield 12B Speed Display; base unit w/ mounting bracket, Can be Upgraded to TrafficCloud 048338 Serial Nos. : 12860125010130, 12860125010230	Each	2	2	2,449.02	4,898.04
4001299 3 Year Warranty 048338	Each	2	2		
4001816 Integrated Solar pole mount battery kit (Sh12) 11.5Ah batt, LFP charger & solar controller 048338	Each	2	2	596.70	1,193.40
4000659 Solar panel, 50W; includes bracket for pole and harness	Each	2	2	496.74	993.48
4001190 Discount - New Purchase	Each	1	1	-2,000.00	-2,000.00

Subtotal: 5,314.92
Invoice Discount: 0.00
Total Sales Tax: 0.00

Total USD: 5,314.92
Payment Applied: 0.00
Remaining Amount: 5,314.92

All prices are listed in US Dollar (USD)
For terms and conditions, please visit <https://www.tapconet.com/terms-conditions>



Safe travels.

5100 West Brown Deer Road, Brown Deer, WI 53223
Phone 800.236.0112 / 262.649.5125 · Fax 262.649.5142
Email: tapco@tapconet.com · www.tapconet.com

Certificate of Conformance

The TAPCO product(s) listed on this invoice was produced or procured in accordance with TAPCO's standard manufacturing and/or procurement processes which were in effect at the time of the processing. TAPCO hereby certifies that the material(s) described were inspected under the general supervision of authorized departmental individuals prior to being placed in stock or released for shipment and was found to comply TAPCO's required specifications and procedures. This includes those specifications and procedures accompanying the original purchase order; amendments related thereto, and additional specifications & procedures mutually agreed upon in writing.

Signed:

Paul Schmidbauer

Compliance Manager
Office: 262-649-5256

paul.schmidbauer@tapconet.com

[Visit us at TAPCO.net](http://www.tapconet.com)



Safe travels.

TOP WORK PLACES 2023, JOURNAL SENTINEL

Limitation of Liability: Except where prohibited by law, TAPCO, Inc. will not be liable for any loss of damage arising from the TAPCO product, whether direct, indirect, incidental or consequential, regardless of legal theory asserted, including warranty, contract, negligence or strict liability.

This certificate or any information contained in it does not amend or change any applicable TAPCO terms and conditions of sale.



INVOICE

AquaCal AquaCal

2737 24th Street North, St. Petersburg, FL 33713,
UNITED STATES

Website: <https://www.aquacal.com/>

Invoice No#: INV-WO0070778

Invoice Date: Sep 10, 2025

Reference: INV-WO0070778



\$502.50 USD

AMOUNT DUE

BILL TO

Harbor Bay Community Development District
C/O Rizzetta & Company
3434 Colwell Avenue, Suite 200
Tampa, FL 33614
fieldops@mirabayclub.com

SHIP TO

Mira Bay Club
107 Manns Harbor Drive, Apollo Beach, FLORIDA
33572, UNITED STATES

#	ITEMS & DESCRIPTION	QTY/HRS	PRICE	AMOUNT(\$)
1	SENSOR,TSTAT,10K RT ANGLE, BLUE	1	\$0.00	\$0.00
2	SENSOR,TSTAT,10K RT ANGLE, GREEN	1	\$0.00	\$0.00
3	Service Charge	1	\$125.00	\$125.00
4	Service Charge	1	\$235.00	\$235.00
5	Sensor (water/temp) replacement - non-taxable	1	\$142.50	\$142.50
			Subtotal	\$502.50
			Sales Tax	\$0.00
			TOTAL	\$502.50 USD

NOTES TO CUSTOMER

Asset #1 needs fan motor replacement. Motor disconnected for now due to noise. Will quote...Asset #2 needed new water sensors due to OTA fault. Replaced both.

Date- 07-05-26

GL Code- 572004833

Approved by- [Signature]

Blue Water Aquatics, Inc.
 5119 State Road 54
 New Port Richey, FL 34652
 (727) 842-2100
 office@bluewateraquaticsinc.com
 www.bluewateraquaticsinc.com



BILL TO
 Harbor Bay CDD
 c/o Rizzetta & Company, Inc.
 3434 Colwell Ave, Suite 200
 Tampa, FL 33614 United States

INVOICE 34958

DATE 01/31/2026 TERMS Net 45

DUE DATE 03/17/2026

SERVICE DATE	SERVICE	DESCRIPTION	QTY	RATE	AMOUNT
01/08/2026	Pond / Waterway Treatment	Aquatic Services - Visit #1 (Included) Treatment Report Emailed to PM	1	0.00	0.00
01/08/2026	Fountain Inspection & PM Cleaning	Fountain Inspection & Preventative Maintenance Cleaning Services Visit #1 (Included) Service Report Emailed to PM	1	0.00	0.00
01/21/2026	Pond / Waterway Treatment	Aquatic Services - Visit #2 Treatment Report Emailed to PM	1	3,640.00	3,640.00
01/21/2026	Fountain Inspection & PM Cleaning	Fountain Inspection & Preventative Maintenance Cleaning Services Visit #2 (Included) Service Report Emailed to PM	1	0.00	0.00
01/31/2026	Monthly Management Report	Monthly Management Report (No Charge) Emailed to PM	1	0.00	0.00

Pay invoice

SUBTOTAL 3,640.00
 TAX 0.00
 TOTAL 3,640.00

TOTAL DUE \$3,640.00

THANK YOU for choosing Blue Water Aquatics, Inc.!



FEB 13 2026

Exclusive savings for Spectrum Business Internet customers

Spectrum Mobile Business Unlimited
4 lines for
\$80 /mo total
 Business Internet is required.
 Corporate Liability plans available.

Add up to 20 lines at the same low price per line

- **Unlimited talk, text and data** (reduced speeds after 30 GB)
- **No fees** for mobile hotspot data
- **Nationwide 5G** included

J.D. POWER AWARD

#1 in Customer Satisfaction
 for Small Business Internet Service



Call 1-833-740-0764 or Visit spectrum.com/business/mobile

Limited-time offer; subject to change. Qualified Spectrum Business customers only. Must not have subscribed to applicable services w/ in the last 30 days & have no outstanding obligation to Charter. Standard rates apply after promo period or if qualifying services not maintained. **BUSINESS UNLIMITED MOBILE:** Per line activation fee, Spectrum Business Internet and Auto Pay required. Devices excluded from offer. Smartwatch does not qualify as a line. Reduced speeds after 30 GB of usage per line, 10 GB for Mobile Hotspots. **J.D. POWER AWARD:** For J.D. Power 2025 award information, visit jdpower.com/awards. Services subject to all applicable service terms & conditions, which are subject to change. Services & promo. offers not avail. in all areas. Pricing subject to change. Installation & other equipment charges, taxes & fees may apply. Restrictions apply. Call for details. ©2025 Charter Communications, all rights reserved.

BAP-2509-NMOB

SA1QF00F



4145 S. FALKENBURG RD RIVERVIEW FL 33578-8652
8633 2390 DY RP 05 02062028 NNNNNNNN 01 001067 0004

HARBOR BAY CDD
GMS TAMPA LLC
3434 COLWELL AVE STE 200
TAMPA FL 33614-8390

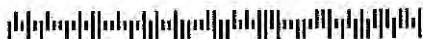

833712028238045300215889

February 5, 2026

Invoice Number:
Account Number:
Security Code:

Harbor Bay Cdd
2380453020526
8337 12 028 2380453



Contact Us

Visit us at SpectrumBusiness.net
Or, call us at **855-252-0675**

8693 2380 DY RP 05 02062026 NNNNNNNN 01 001087 0004



February 5, 2026
Invoice Number: 2380453020526
Account Number: 8337 12 028 2380453
Security Code:
Service At: 5248 ADMIRAL POINTE DR
APOLLO BEACH FL 33572-3429

Auto Pay Notice

NEWS AND INFORMATION

You've been selected for exclusive multi-line mobile savings. Call 1-833-574-1237 now.

Contact Us

Visit us at SpectrumBusiness.net
Or, call us at 855-252-0675

Summary *Service from 02/05/26 through 03/04/26
details on following pages*

Previous Balance	204.90
Payments Received -Thank You!	-204.90
Remaining Balance	\$0.00
Spectrum Business™ TV	45.00
Spectrum Business™ Internet	160.00
Other Charges	5.00
Taxes, Fees and Charges	5.88
Current Charges	\$215.88
YOUR AUTO PAY WILL BE PROCESSED 02/22/26	
Total Due by Auto Pay	\$215.88

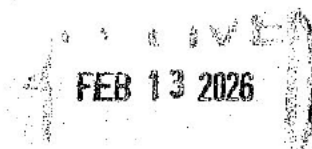

Thank you for choosing Spectrum Business.
We appreciate your prompt payment and value you as a customer.

Auto Pay - Thank you for signing up for Auto Pay. Please note your payment may be drafted and posted to your Spectrum Business account the day after your transaction is scheduled to be processed by your bank.



4145 S. FALKENBURG RD RIVERVIEW FL 33578-8652
8633 2390 DY RP 05 02062026 NNNNNNNN 01 001087 0004

HARBOR BAY CDD
GMS TAMPA LLC
3434 COLWELL AVE STE 200
TAMPA FL 33614-8390

February 5, 2026

HARBOR BAY CDD

Invoice Number: 2380453020526
Account Number: 8337 12 028 2380453
Service At: 5248 ADMIRAL POINTE DR
APOLLO BEACH FL 33572-3429

Total Due by Auto Pay \$215.88

CHARTER COMMUNICATIONS
PO BOX 7186
PASADENA CA 91109-7186





Invoice Number: HARBOR BAY CDD
 Account Number: 2380453020526
 Security Code: 8337 12 028 2380453

Contact Us
 Visit us at SpectrumBusiness.net
 Or, call us at **855-252-0675**

8833 2890 DY RP 05 02082026 NNNNNNNN 01 001067 0004

Charge Details

Previous Balance		204.90
EFT Payment	01/22	-204.90
Remaining Balance		\$0.00

Payments received after 02/05/26 will appear on your next bill.
 Service from 02/05/26 through 03/04/26

Spectrum Business™ TV

Business TV Stream	45.00
Spectrum Business™ TV Total	\$45.00

Spectrum Business™ Internet

Spectrum Business Internet	130.00
Business WIFI	10.00
Security Suite	0.00
Domain Name	0.00
Vanity Email	0.00
Static IP 1	20.00
Spectrum Business™ Internet Total	\$160.00

Other Charges

Payment Processing	10.00
Auto Pay Discount	-10.00
Paper Bill Stmt Charge	5.00
Other Charges Total	\$5.00

Taxes, Fees and Charges

State and Local Sales Tax	0.38
Communications Services Tax	5.50
Taxes, Fees and Charges Total	\$5.88

Taxes, Fees and Charges Continued

Current Charges	\$215.88
Total Due by Auto Pay	\$215.88

Billing Information

Tax and Fees - This statement reflects the current taxes and fees for your area (including sales, excise, user taxes, etc.). These taxes and fees may change without notice. Visit spectrum.net/taxesandfees for more information.

Spectrum Terms and Conditions of Service - In accordance with the Spectrum Business Services Agreement, Spectrum services are billed on a monthly basis. Spectrum does not provide credits for monthly subscription services that are canceled prior to the end of the current billing month.

Terms & Conditions - Spectrum's detailed standard terms and conditions for service are located at spectrum.com/policies.

Notice - Nonpayment of any portion of your cable television, high-speed data, and/or Digital Phone service could result in disconnection of any of your Spectrum provided services.

Insufficient Funds Payment Policy - Charter may charge an insufficient funds processing fee for all returned checks and bankcard charge-backs. If your check, bankcard (debit or credit) charge, or other instrument or electronic transfer transaction used to pay us is dishonored, refused or returned for any reason, we may electronically debit your account for the payment, plus an insufficient funds processing fee as set forth in your terms of service or on your Video Services rate card (up to the amount allowable by law and any applicable sales tax). Your bank account may be debited as early as the same day payment is dishonored, refused or returned. If your bank account is not debited, the returned check amount (plus fee) must be replaced by cash, cashier's check or money order.

Continued on the next page...

Local Spectrum Store: 12970 S US Hwy 301, Suite 105, Riverview FL 33579 Store Hours: Mon thru Sat - 10:00am to 8:00pm; Sun - 12:00pm to 7:00pm

Local Spectrum Store: 872 Brandon Town Center Mall, Brandon FL 33511 Store Hours: Mon thru Sat - 10:00am to 8:00pm and Sun - 12:00pm to 5:00pm

For questions or concerns, please call 1-866-519-1263.



February 5, 2026



Invoice Number: HARBOR BAY CDD
2380453020526
Account Number: 8337 12 028 2380453
Security Code:

Contact Us

Visit us at SpectrumBusiness.net
Or, call us at **855-252-0675**

6633 2390 DY RP 05 02062026 NNNNNNNN 01 001067 0004

Billing Practices - Spectrum Business mails monthly, itemized invoices for all monthly services in advance. A full payment is required on or before the due date indicated on this invoice. Payments made after the indicated due date may result in a late payment processing charge. Failure to pay could result in the disconnection of all your Spectrum Business service(s). Disconnection of Business Voice service may also result in the loss of your phone number.

Changing Business Locations - Please contact Spectrum Business before moving your Business Voice modem to a new address. To establish service at your new location or return equipment, please contact Spectrum Business at least twenty-one (21) business days prior to your move.

Past Due Fee / Late Fee Reminder - A late fee will be assessed for past due charges for service.

Complaint Procedures: If you disagree with your charges, you need to register a complaint no later than 60 days after the due date on your bill statement.

Video Closed Captioning Inquiries - Spectrum provided set-top boxes for video consumption support the ability for the user to enable or disable Closed Captions for customers with hearing impairment.

For immediate closed captioning concerns, call **855-70-SPECTRUM** or email closedcaptioningsupport@charter.com.

To report a complaint on an ongoing closed captioning issue, please send your concerns via US Mail to W. Wesselman, Sr. Director, 2 Digital Place, Simpsonville, SC 29681, send a fax to **1-704-697-4935**, call **1-877-276-7432** or email closedcaptioningissues@charter.com.



February 5, 2026



Invoice Number:
Account Number:
Security Code:

HARBOR BAY CDD
2380453020526
8337 12 028 2380453

Contact Us

Visit us at SpectrumBusiness.net
Or, call us at **855-252-0675**

8633 2390 DY RP 05 02062026 NNNNNNNN 01 001067 0004



INVOICE



Service Address

107 Manns Harbor Dr
Apollo Beach, FL
33572

Bill To

Harbor Bay
Community
Development District
3434 Colwell Avenue,
Suite 200, c/o Rizzetta
& Company (attn:
Lynn Hayes)
Tampa, FL 33614
(813) 649-1500
(813) 994-1001

Date- 02-05-26

GL Code- 539004829

Approved by- JN

Payment terms 30 Days
Invoice # 333
Date 01/31/2026
Business / Tax # 86-3121827

CORE Pressure & Sealing

5233 Admiral Pointe Dr
Apollo Beach, FL 33572
Phone: (813) 586-4636
Email: corepressureclean@gmail.com
Web: www.corepressuresealing.com

Description

Rate

Pressure wash project yearly contract	\$2,200.00
- areas conveyed by CDD (Community Development District)	
- Manns Harbor Sidewalks X Playground Area	
- Manns Harbor Entrance Sidewalks from the gate to the homes (both sides)	
- Main Clubhouse x Entrance Sidewalks to the right	
- Docks	
- AP Clubhouse x Sidewalk	
- AP Sidewalk Right section from the Gate out	



Subtotal \$2,200.00

Total **\$2,200.00**

Scan to Pay Online



better water. pure and simple.®

2703 AIRPORT ROAD
PLANT CITY, FL 33563
813-759-6060

Invoice #	5140655
Date:	01/31/2026
Customer:	1230317
Purchase Order	

Delivery Address

Harbor Bay Comm Dev Dist.
Rizzetta & Company
3434 Colwell Avenue Suite 200
TAMPA, FL 33614

MIRABAY CLUB
107 MANN'S HARBOR DRIVE
APOLLO BEACH, FL 33572

JOEL NEWTON-FIELD OPERATIONS MGR
813-649-3020

Terms N30

Code	Item	Qty	Price	Total
2834	Culligan WS 12000 ICE	1.000	69.00	69.00

2/1/2026 To 2/28/2026

SubTotal Sales:	69.00
Sales Tax:	0.00
Invoice Total:	69.00

Thank you for your business
Pay your bill online using our secure payment page at www.tampaculligan.com

Date- 02-03-26

GL Code- 572004103

Approved by- [Signature]



INVOICE

Please Make Check out to Custom Reserves

Custom Reserves
contact@customreserves.com
5470 E Busch Blvd, Unit 171
Tampa, Florida 33617
United States

Fax: (813) 200-8448
Toll free: (888) 927-7865
www.customreserves.com

BILL TO
Harbor Bay Community Development District
C/o Rizzetta & Company
3434 Colwell Avenue, Suite 200
Tampa, Florida 33614
United States

813.994.100
LHayes@rizzetta.com

Invoice Number: R82.26

Invoice Date: February 25, 2026

Payment Due: February 25, 2026

Amount Due (USD): \$2,350.00

 [Pay Securely Online](#)

Product/Service	Quantity	Price	Amount
Update with Site Visit Retainer Payment - Site visits are prioritized based on receipt date.	0.5	\$4,700.00	\$2,350.00

Total: \$2,350.00

Amount Due (USD): \$2,350.00

[Pay Securely Online](#)

VISA



DISCOVER

Bank Payment

link.waveapps.com/vc3chk-gjefbz

Notes / Terms

Please add the 2% service fee for credit card payments only.

Thank you for allowing Custom Reserves to be a continued resource for your community!

Powered by  wave

Harbor Bay CDD BOS Meeting

Meeting Date: January 15, 2026

SUPERVISOR PAY REQUEST

Name of Board Supervisor	Check if Paid
Daniel Leventry	<input checked="" type="checkbox"/>
Michael Rodriguez	<input checked="" type="checkbox"/>
Dean Walters	<input checked="" type="checkbox"/>
Tim Nargi	<input checked="" type="checkbox"/>
Steve Finley	<input checked="" type="checkbox"/>

(*) Does not get paid

NOTE: Supervisors are only paid if checked present.

EXTENDED MEETING TIMECARD

Meeting Start Time:	6:00 pm
Meeting End Time:	8:24 pm
Total Meeting Time:	

Time Over (3) Hours:	0
------------------------	---

Total at \$200 per Hour:	\$0.00
--------------------------	--------

ADDITIONAL OR CONTINUED MEETING TIMECARD

Meeting Date:	0
Additional or Continued Meeting?	0
Total Meeting Time:	0
Total at \$200 per Hour:	\$0.00

Business Mileage Round Trip	0
IRS Rate per Mile	\$0.700
Mileage to Charge	\$0.00

DM Signature: _____



Harbor Bay CDD BOS Meeting
 Meeting Date: February 19, 2026

SUPERVISOR PAY REQUEST

Name of Board Supervisor	Check if Paid
Daniel Leventry	✓
Michael Rodriguez	✓
Dean Walters	✓
Tim Nargi	✓
Steve Finley	✓

(*) Does not get paid

NOTE: Supervisors are only paid if checked present.

EXTENDED MEETING TIMECARD

Meeting Start Time:	6:00 pm
Meeting End Time:	10:04 pm
Total Meeting Time:	4 hours & 4 minutes
Time Over (3) Hours:	1 hour & 4 minutes (1.25 overtime)
Total at \$200 per Hour:	\$250.00 \$0.00

ADDITIONAL OR CONTINUED MEETING TIMECARD

Meeting Date:	0
Additional or Continued Meeting?	0
Total Meeting Time:	0
Total at \$200 per Hour:	\$0.00
Business Mileage Round Trip	0
IRS Rate per Mile	\$0.700
Mileage to Charge	\$0.00

DM Signature: 



CONTRACT INVOICE

Post Office Box 17299 Clearwater, FL 33762-0299
P: (800) 995-4468 F: (813) 288-0223
EIN:

Invoice Number: AR14555323
Invoice Date: 1/2/2026

Bill To: Harbour Bay Community Development District
Harbour Bay Community Development District
C/o Rizzetta & Company
3434 Colwell Ave. Suite 200
Tampa, FL 33614
US

Customer: Harbour Bay Community Development District
C/o Rizzetta & Company
3434 Colwell Ave. Suite 200
Tampa, FL 33614

Account No	Payment Terms	Due Date	Invoice Total	Balance Due
HB87	30 Days	2/1/2026	\$329.74	\$329.74
Invoice Remarks				

Contract Number	Contact	Contract Amount	P.O. Number	Start Date	Exp. Date
DX64326-01		\$329.74		7/1/2022	
Contract Remarks					

Summary:

Contract base rate charge for the 01/01/2026 to 03/31/2026 billing period	\$35.12 *
Contract overage charge for the 10/01/2025 to 12/31/2025 overage period	\$289.62 **
Tariff Offset	\$5.00
	\$329.74

*Sum of equipment base charges **See overage details below

Detail:

Equipment included under this contract

107 Manns Harbor Dr
Clubhouse Office

Kyocera/Kyocera ECOSYS M6635cidn

Number	Serial Number	Base Charge	Location
209581	RC42320107	\$35.12	Harbour Bay Community Development District 107 Manns Harbor Dr Apollo Beach, FL 33572 Clubhouse Office

Meter Type	Meter Group	Begin Meter	End Meter	Total	Covered	Billable	Rate	Overage
FVirtual	Shipping	89,472	96,731	7,259	0	7,259	\$0.000850	\$6.17
Color	Color	37,942	40,514	2,572	0	2,572	\$0.098300	\$252.83
B\W	B\W	51,530	56,217	4,687	2,500	2,187	\$0.014000	\$30.62
								\$289.62

Did you know you can place your supply order online?
Try <https://www.deximaging.com> and click on "Get Supplies"

Please note that due to rising processing costs, credit card charges will be subjected to a 3% processing surcharge. If this invoice is paid with a credit card, you will be charged \$339.63 If you do not pay with a credit card, the total amount on this invoice is due. If you wish to update your payment method, please call DEX Imaging Accounts Receivables at (813) 288-8080. We appreciate your business and thank you for your understanding.

Invoice SubTotal	\$329.74
Tax:	\$0.00
Invoice Total	\$329.74
Balance Due:	\$329.74



DIRECTV
FOR BUSINESS

ACCOUNT NUMBER
057414714

DATE DUE
02/25/26

AMOUNT DUE
\$334.29

INVOICE NUMBER
057414714X260211

To contact us call 1-888-388-4249

Summary

Statement Date: 02/11/26

Page 1 of 1 for:

HARBOR BAY CDD

For Service at:

KYLE DARIN

107 MANNS HARBOR DR

APOLLO BEACH, FL 33572-3340

Previous Balance	334.29
Payments	-334.29
Current Charges & Fees	314.98
Adjustments & Credits	-15.00
Taxes	34.31
Amount Due	\$334.29



Call to order
1.855.325.1061

Activity

Start	End	Description	Amount
		Previous Balance	334.29
01/25		EFT Payment - Thank You	-334.29
Current Charges for Service Period 02/10/26 - 03/09/26			
02/10	03/09	Music Choice Premium Monthly	49.99
02/10	03/09	Xtra Pack 2of3 Monthly	26.00
02/10	03/09	Xtra Pack 1of3 Monthly	115.99
02/10	03/09	Xtra Pack TV Access Fee 4	60.00
02/10	03/09	Xtra Pack 3of3 Monthly	43.00
12/16	01/15	NFL SUNDAY TICKET 2025 5-Pay	0.00
Fees			
02/11		Regional Sports Fee	20.00
Adjustments & Credits			
02/10	03/09	Music Choice Premium Save \$15 Off TV Access Fee	-15.00 Credit
		Communications Service Tax	34.31
		AMOUNT DUE	\$334.29

RECEIVED
FEB 19 2026

BY:

006083 1/1

1,6

PLEASE FOLD ALONG PERFORATION, DETACH AND RETURN THIS PORTION WITH YOUR PAYMENT

DIRECTV
FOR BUSINESS

INVOICE NUMBER
057414714X260211

DATE DUE
02/25/26

ACCOUNT NUMBER
057414714

AMOUNT DUE
\$334.29

PAYMENT ENCLOSED

DO NOT WRITE OTHER COMMENTS ON THIS FORM

CONFIRMATION of Auto Bill Pay Enrollment by ELECTRONIC FUNDS TRANSFER. Payment will occur on or about 02/25/26.

MB 01 006083 26901 H 20 C
HARBOR BAY CDD
C/O RIZZETTA & COMPANY
3434 COLWELL AVE STE 200
TAMPA FL 33614-8390



500600000000000000057414714 9 0028 00033429 00033429 0

Envera

8281 Blaikie Court
 Sarasota, FL 34240
 (941) 556-7066

Invoice	
Invoice Number 765034	Date 02/01/2026
Customer Number 300233	Due Date 03/01/2026

Page: 1

Customer Name	Customer Number	PO Number	Invoice Date	Due Date
Harbor Bay CDD	300233		02/01/2026	03/01/2026

Quantity	Description	Months	Rate	Amount
<i>3053 - Gate Access - Harbor Bay CDD - Mirabay, Admiral Pointe, Bay Breeze, Apollo Beach, FL</i>				
1.00	ISP Pass Thru 03/01/2026 - 03/31/2026	1.00	\$104.28	\$104.28
1.00	Envera Kiosk System 03/01/2026 - 03/31/2026	1.00	\$1,699.50	\$1,699.50
1.00	Data Management 03/01/2026 - 03/31/2026	1.00	\$257.50	\$257.50
1.00	Bluetooth License 03/01/2026 - 03/31/2026	1.00	\$99.84	\$99.84
1.00	Passive License Plate Cam 03/01/2026 - 03/31/2026	1.00	\$103.00	\$103.00
1.00	Passive Standard Camera 03/01/2026 - 03/31/2026	1.00	\$128.75	\$128.75
1.00	Burglar Alarm Monitoring 03/01/2026 - 03/31/2026	1.00	\$20.60	\$20.60
1.00	Active Video Monitoring 03/01/2026 - 03/31/2026	1.00	\$927.00	\$927.00
1.00	Active Video Monitoring 03/01/2026 - 03/31/2026	1.00	\$144.20	\$144.20

Date	Invoice #	Description	Amount	Balance Due
2/1/2026	765034	Monitoring Services	\$18268.51	\$18175.81

Envera

8281 Blaikie Court
 Sarasota, FL 34240
 (941) 556-7066

Invoice	
Invoice Number 765034	Date 02/01/2026
Customer Number 300233	Due Date 03/01/2026

Net Due: \$18,175.81

Amount Enclosed: _____

Harbor Bay CDD
 C/O Rizzetta & Company
 3434 Colwell Avenue Suite 200
 Tampa, FL 33614

REMIT TO:

Envera
 PO Box 2086
 Hicksville, NY 11802

Envera

8281 Blaikie Court
 Sarasota, FL 34240
 (941) 556-7066

Invoice	
Invoice Number 765034	Date 02/01/2026
Customer Number 300233	Due Date 03/01/2026

Page: 2

Customer Name	Customer Number	PO Number	Invoice Date	Due Date
Harbor Bay CDD	300233		02/01/2026	03/01/2026

Quantity	Description	Months	Rate	Amount
1.00	Service & Maintenance 03/01/2026 - 03/31/2026	1.00	\$1,708.22	\$1,708.22
1.00	Service & Maintenance 03/01/2026 - 03/31/2026	1.00	\$51.27	\$51.27
1.00	Virtual Gate Guard Monitoring 03/01/2026 - 03/31/2026	1.00	\$13,024.35	\$13,024.35
			Subtotal:	\$18268.51
Tax				\$0.00
Payments/Credits Applied				\$92.70
			Invoice Balance Due:	\$18175.81

Date	Invoice #	Description	Amount	Balance Due
2/1/2026	765034	Monitoring Services	\$18268.51	\$18175.81

Envera

8281 Blaikie Court
 Sarasota, FL 34240
 (941) 556-7066

Invoice	
Invoice Number 765034	Date 02/01/2026
Customer Number 300233	Due Date 03/01/2026

Net Due: \$18,175.81

Amount Enclosed: _____

Harbor Bay CDD
 C/O Rizzetta & Company
 3434 Colwell Avenue Suite 200
 Tampa, FL 33614

REMIT TO:

Envera
 PO Box 2086
 Hicksville, NY 11802

Envera

8281 Blaikie Court
 Sarasota, FL 34240
 (941) 556-7066

Invoice	
Invoice Number 765741	Date 02/10/2026
Customer Number 300233	Due Date 04/01/2026

Page: 1

Customer Name	Customer Number	PO Number	Invoice Date	Due Date
Harbor Bay CDD	300233		02/10/2026	04/01/2026

Quantity	Description	Months	Rate	Amount
1.00	Harbor Bay CDD - Mirabay, Admiral Pointe, Bay Breeze, Apollo Beach, FL Add Res as of 1/31/26 02/01/2026 - 03/31/2026	2.00	\$18.54	\$37.08
			Subtotal:	\$37.08
			Tax	\$0.00
			Payments/Credits Applied	\$0.00
			Invoice Balance Due:	\$37.08

MyEnvera Count as of 1/31/26. 2 additional homes @ \$9.27 each

Date	Invoice #	Description	Amount	Balance Due
2/10/2026	765741	Monitoring Services	\$37.08	\$37.08

Envera

8281 Blaikie Court
 Sarasota, FL 34240
 (941) 556-7066

Invoice	
Invoice Number 765741	Date 02/10/2026
Customer Number 300233	Due Date 04/01/2026

Net Due: \$37.08

Amount Enclosed: _____

Harbor Bay CDD
 C/O Rizzetta & Company
 3434 Colwell Avenue Suite 200
 Tampa, FL 33614

REMIT TO: Envera
 PO Box 2086
 Hicksville, NY 11802



HARBOR BAY COMMUNITY DEVELOP Account Number: 239-100-0051-031720-5

Billing Date: Jan 25, 2026

PIN:

Billing Period: Jan 25 - Feb 24, 2026

Hi HARBOR BAY COMMUNITY DEVELOP,

Thank-you for choosing Frontier, a Verizon Company. Have questions about your bill? Visit us at frontier.com/billing to learn more.



Bill history

Previous balance	\$5,143.87
Payment not received by Jan 25	\$0.00
Prior bill period balance	\$5,143.87
Please pay past due immediately	\$5,143.87

Service summary

	Previous month	Current month
Bundle	\$2,490.50	↑\$2,590.50
One-Time Charges	\$52.19	↑\$91.16
Taxes and Fees	\$55.34	↓\$54.68
Total services	\$2,598.03	\$2,736.34
Total balance		\$7,880.21

\$2,736.34 due Feb 18

Manage your account, payments, and services anytime, anywhere with the MyFrontier app. Download your free app today. To learn more visit frontier.com/myfrontierapp

Earn more. Get started with a business referral and earn up to \$325 per referral. Learn more: https://www.businessreferralrewards.com



P.O. Box 211579 Eagan, MN 55121-2879

6790 0107 DY RP 25 01272026 NNNNNNNY 01 000001 0036

HARBOR BAY COMMUNITY DEVELOP PO BOX 32414 CHARLOTTE NC 28232-2414

Total balance \$7,880.21

Account number 239-100-0051-031720-5

Due by Feb 18

Amount enclosed \$

Mail payment to: FRONTIER PO BOX 740407 CINCINNATI, OH 45274-0407



814014239100005103172000000052190007880215



HARBOR BAY COMMUNITY Account Number:
DEVELOP 239-100-0051-031720-5

Billing Date:
Jan 25, 2026

PIN:

Billing Period:
Jan 25 - Feb 24, 2026



WAYS TO PAY YOUR BILL



Easy, simple, secure payments with
Auto Pay at frontier.com/autopay



Download the
MyFrontier[®] app



For help: Customer Service at frontier.com/helpcenter, chat at frontier.com/chat, or call us at 800-921-8102.
Visually impaired/TTY customers, call 711.

PAYING YOUR BILL

You are responsible for all legitimate, undisputed charges on your bill. Paying by check authorizes Frontier to make a one-time electronic funds transfer from your account, as early as the day your check is received. When making an online payment, please allow time for the transfer of funds. If funds are received after the due date, you may be charged a fee, your service may be interrupted, and you may incur a reconnection charge to restore service. A fee may be charged for a bank returned check. Continued nonpayment of undisputed charges (incl. 900 and long distance charges) may result in collection action and a referral to credit reporting agencies, which may affect your credit rating.

IMPORTANT MESSAGES

You must pay all basic local service charges to avoid basic service disconnection. Failure to pay other charges will not cause disconnection of your basic service but this may cause other services to be terminated. Frontier Bundles may include charges for both basic and other services. Frontier periodically audits its bills to ensure accuracy which may result in a retroactive or future billing adjustment. Internet speed, if noted, is the maximum wired connection speed for selected tier; Wi-Fi speeds may vary; actual and average speed may be slower and depends on multiple factors. Performance details are at frontier.com/internetdisclosures.

SERVICE TERMS

Visit frontier.com/terms, frontier.com/tariffs or call Customer Service for information on tariffs, price lists and other important Terms, Conditions and Policies ("Terms") related to your voice, internet and/or video services including limitations of liability, early termination fees, the effective date of and billing for the termination of service(s) and other important information about your rights and obligations, and ours. Frontier's Terms include a binding arbitration provision to resolve customer disputes (frontier.com/terms/arbitration). **Video and Internet services are subscription-based and are billed one full month in advance. Video and/or Internet service subscription cancellations and any early termination fees are effective on the last day of your Frontier billing cycle. No partial month credits or refunds will be provided for previously billed service subscriptions.** By using or paying for Frontier services, you are agreeing to these Terms and that disputes will be resolved by individual arbitration. By providing personal information to Frontier you are also agreeing to Frontier's Privacy Policy posted at frontier.com/privacy.



HARBOR BAY COMMUNITY Account Number:
DEVELOP 239-100-0051-031720-5

Billing Date:
Jan 25, 2026

PIN:

Billing Period:
Jan 25 - Feb 24, 2026

Don't let an unexpected outage stop your business. Get Frontier Internet Backup to keep your critical systems running. Visit: business.frontier.com/internet-backup

Master Summary Activity

Summary of charges by Account

Phone Number	Amount
239-017-3244 0	\$439.08
239-100-0051 0	\$91.16
239-113-4095 0	\$508.57
239-157-7717 0	\$160.98
239-167-4348 0	\$160.98
239-179-7790 0	\$160.98
305-157-2694 0	\$160.98
813-641-0919 0	\$125.98
813-645-0799 0	\$135.98
813-645-3359 0	\$125.98
813-649-1333 0	\$665.67

Total current month charges

\$2,736.34

**LET FRONTIER
 BE YOUR
 TECH SUPPORT**

Tech issues won't wait until you have an IT team to fix them. Get the tech support you need without the overhead. Frontier Premium Tech Pro.

business.frontier.com





HARBOR BAY CDD Account Number:
 107 MANN'S HARBOR DR 239-017-3244-092203-5
 OFC OFC
 APOLLO BEACH FL 335723340

Billing Date:
 Jan 25, 2026
 Billing Period:
 Jan 25 - Feb 24, 2026

Bundle

Monthly Charges

01.25-02.24	FiberOptic Internet for Business 75/75 2YR	\$160.98
	5 IP Addresses	\$30.00
	FiberOptic TV Extreme HD Private	\$189.99
	Sports/Broadcast TV Fee	\$29.99
	Digital Adapter Rental	\$5.99
(2)	TV Standard Set-Top Box	\$22.00
Bundle Total		\$438.95

Taxes and Fees

	FCC Regulatory Recovery Fee	\$0.13
	Video	\$0.13
Taxes and Fees Total		\$0.13

Total current month charges

		\$439.08
Amount Transferred to 239-100-0051		\$439.08

Frontier Bundled Video Service

Total Video Programming Charges

FiberOptic TV Extreme HD Private	\$189.99
Sports/Broadcast TV Fee	\$29.99

Total	\$219.98
--------------	-----------------

239-017-3244

88/KQXA/413598/ /VZFL



HARBOR BAY COMMUNITY DEVELOP
 760 WINTERSIDE DR
 APOLLO BEACH FL 335720000

Account Number:
239-100-0051-031720-5

Billing Date:
Jan 25, 2026
 Billing Period:
Jan 25 - Feb 24, 2026

One-Time Charges

	Late Payment Fee	\$91.16
One-Time Charges Total		\$91.16

Total current month charges **\$91.16**



Account Activity

2391000051

Qty	Description	Order number	Effective date	Charge
1	Late Payment Fee		2026-01-25	\$91.16
Total				\$91.16



HARBOR BAY CDD Account Number:
 5248 ADMIRAL POINTE DR 239-113-4095-021516-5
 APOLLO BEACH FL 33572

Billing Date:
 Jan 25, 2026
 Billing Period:
 Jan 25 - Feb 24, 2026

Bundle

Monthly Charges

01.25-02.24	FiberOptic Extreme HD Pub	\$209.99
	Sports/Broadcast TV Fee	\$29.99
	HD Set Top Box	\$17.49
	FiberOptic Internet for Business 150/150 2YR	\$250.97
Bundle Total		\$508.44

Taxes and Fees

FCC Regulatory Recovery Fee	\$0.13
Video	\$0.13

Taxes and Fees Total

\$0.13

Total current month charges

\$508.57

Amount Transferred to 239-100-0051

\$508.57

Frontier Bundled Video Service

Total Video Programming Charges

FiberOptic Extreme HD Pub	\$209.99
Sports/Broadcast TV Fee	\$29.99

Total

\$239.98

239-113-4095

88/KQXA/948869/ /NZFL



HARBOR BAY CDD Account Number:
426 MIRABAY BLVD 239-157-7717-030314-5
APOLLO BEACH FL 33572

Billing Date:
Jan 25, 2026
Billing Period:
Jan 25 - Feb 24, 2026

Bundle

Monthly Charges

01.25-02.24 FiberOptic Internet for Business 75/75 2YR \$160.98

Bundle Total \$160.98

Total current month charges \$160.98

Amount Transferred to 239-100-0051 \$160.98



239-157-7717

88/KQXAJ480617/ NZFL



HARBOR BAY CDD Account Number:
103 MIRABAY BLVD 239-167-4348-030314-5
TAMPA FL 33572

Billing Date:
Jan 25, 2026
Billing Period:
Jan 25 - Feb 24, 2026

Bundle

Monthly Charges

01.25-02.24 FiberOptic Internet for Business.75/75 2YR \$160.98

Bundle Total \$160.98

Total current month charges \$160.98

Amount Transferred to 239-100-0051 \$160.98

239-167-4348

88/KQXA/480599/ /VZFL





HARBOR BAY CDD Account Number:
632 BALIBAY RD 239-179-7790-030314-5
APOLLO BEACH FL 33572

Billing Date:
Jan 25, 2026
Billing Period:
Jan 25 - Feb 24, 2026

Bundle

Monthly Charges

01.25-02.24 FiberOptic Internet for Business 75/75 2YR \$160.98

Bundle Total \$160.98

Total current month charges \$160.98

Amount Transferred to 239-100-0051 \$160.98



239-179-7790

88/KQXA/480628/ /VZFL



HARBOR BAY CDD Account Number:
200 MIRABAY BLV 305-157-2694-022714-5
APOLLO BEACH FL 33572

Billing Date:
Jan 25, 2026
Billing Period:
Jan 25 - Feb 24, 2026

Bundle

Monthly Charges

01.25-02.24

FiberOptic Internet for Business 75/75 2YR

\$160.98

Bundle Total

\$160.98

Total current month charges

\$160.98

Amount Transferred to 239-100-0051

\$160.98

305-157-2694

88/KGXA/478766/ NVZFL





HARBOR BAY COMMUNITY Account Number:
 DEVELOPME **813-641-0919-072716-5**
 APOLLO BEACH FL 33572

Billing Date:
Jan 25, 2026
 Billing Period:
Jan 25 - Feb 24, 2026

Bundle

Monthly Charges

01.25-02.24	FiberOptic Internet 25/25 Static	\$125.98
-------------	----------------------------------	----------

Bundle Total		\$125.98
---------------------	--	-----------------

Total current month charges	\$125.98
------------------------------------	-----------------

Amount Transferred to 239-100-0051	\$125.98
------------------------------------	----------





ES - HARBOR BAY CDD Account Number:
564 MANN'S HARBOR DR 813-645-0799-081518-5
APOLLO BEACH FL 33572

Billing Date:
Jan 25, 2026
Billing Period:
Jan 25 - Feb 24, 2026

Bundle

Monthly Charges

01.25-02.24 FiberOptic Internet 25/25 Static \$135.98

Bundle Total \$135.98

Total current month charges \$135.98

Amount Transferred to 239-100-0051 \$135.98





HARBOR BAY CDD Account Number:
301 MANNS HARBOR DR **813-645-3359-032520-5**
APOLLO BEACH FL 33572

Billing Date:
Jan 25, 2026
Billing Period:
Jan 25 - Feb 24, 2026

Bundle

Monthly Charges

01.25-02.24 FiberOptic Internet 75 Static IP \$125.98

Bundle Total \$125.98

Total current month charges \$125.98

Amount Transferred to 239-100-0051 \$125.98





HARBOR BAY COMMUNITY DEVELOP
 107 MANNS HARBOR DR
 OFC OFC
 APOLLO BEACH FL 335723340

Account Number:
813-649-1333-101813-5

Billing Date:
Jan 25, 2026
 Billing Period:
Jan 25 - Feb 24, 2026

Bundle

Monthly Charges

01.25-02.24	(3)	Frontier Additional Line - Basic 2 Year Solutions Bundle 2 Yr	\$315.00
	(4)	Federal Primary Carrier Centrex Line	\$157.00
	(4)	Federal Subscriber Line Charge - Centrex	\$71.96
	(4)	Federal Subscriber Line Charge - Centrex	\$36.80
		Carrier Cost Recovery Surcharge	\$13.99
	(4)	Access Recovery Charge Multi Line - Centrex	\$12.00
		Frontier Roadwork Recovery Surcharge	\$4.50
Bundle Total			\$611.25

Taxes and Fees

FCA Long Distance - Federal USF Surcharge	\$36.06
Federal USF Recovery Charge	\$18.36
Federal Taxes	\$54.42

Taxes and Fees Total **\$54.42**

Total current month charges **\$665.67**

Amount Transferred to 239-100-0051 **\$665.67**

Caller Summary Report

Phone #	Calls	Minutes	Amount
813-649-1333	5	12	\$0.00
Total	5	12	\$0.00

Caller Summary Report

Phone #	Calls	Minutes	Amount
Intra-Local	5	12	\$0.00
Total	5	12	\$0.00



HARBOR BAY COMMUNITY Account Number:
DEVELOP 239-100-0051-031720-5

Billing Date:
Jan 25, 2026

Page 15/16

DIAL

Billing Period:
Jan 25 - Feb 24, 2026

If you have a question or concern about Closed Captioning on any program, please call the Frontier Center for Customers with Disabilities at 1-877-462-6606 or email Video.Closed.Captioning@ftr.com Written correspondence can be faxed to 1-805-262-0728, or mailed to Frontier Communications, 2560 Teller Road, Thousand Oaks, CA 91320, Attn: Kate Card. DO NOT mail payment to this address.

For up-to-date channel information please visit: <http://frontier.com/channelupdates>

If your unresolved complaint involves FiberOptic TV, you may contact the Florida Department of Agriculture and Consumer Services, Florida Capital, Tallahassee, FL 32399-0800 or 1-800-435-7352. Your FCC Community ID is: FL1304

If your bill reflects that you owe a Balance Forward, you must make a payment immediately in order to avoid collection activities. You must pay a minimum of \$143.35 by your due date to avoid disconnection of your local service. All other charges should be paid by your due date to keep your account current.

Beginning with this bill, your CustoSak Line (standalone or in a bundle) has increased to the tariff rate of \$123.15 per month, per line. We may have alternative Voice services available in your area. Please call 1-800-921-8102 to learn more.

Beginning with this bill, your CustoSak Line has increased \$25.00 per month, per line. We may have alternative Voice services available in your area. Please call 1-800-921-8102 to learn more.





HARBOR BAY COMMUNITY DEVELOP Account Number: **239-100-0051-031720-5**

PIN:

Billing Date:
Jan 25, 2026

Billing Period:
Jan 25 - Feb 24, 2026





The Difference is Good.

Message Center

Invoice Number: 150069810147

Your auto-pay will draft on the due date and be charged to your bank account.

HARBOR BAY CDD GASLIGHTS
0 MIRABAY BLVD
APOLLO BEACH FL 33572-0000

FEB - 9 2026

Bill Date: 01/30/26
Plan: Florida Index Zone 3

Pay Online: GasSouth.com/pay

Local Distributor: Peoples Gas System Emergencies or Leaks: 877.832.6747 Gas South Customer Care: 866.426.2491 | BizRelations@GasSouth.com

Gas South Account Number	Balance Forward	New Charges	New Charges Due Date	Total Amount Due
1507180292	\$0.00	\$563.37	Feb 19, 2026	\$563.37

Explanation of Charges

Previous Balance	\$534.55
Payment	\$534.55 CR
Balance Forward	\$0.00
Gas Charges	\$438.92
Transportation (@ \$0.0852)	\$62.32
Fuel Charge (@ 2.45%)	\$10.75
Pipeline Charge (@ \$0.00831 Per Therm)	\$6.08
Customer Service Fee	\$5.00
Pool Fee	\$1.00
FL State Tax	\$31.44
Sales Taxes	\$7.86
Municipal Public Service Tax	\$0.00
Total New Charges	\$563.37
Total Amount Due	\$563.37

Consumption History

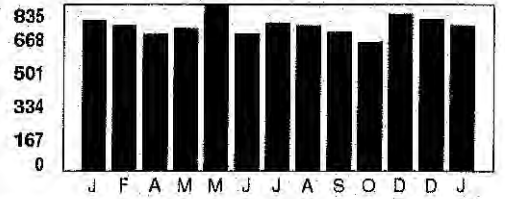

Copyright © 2026 Gas South



Please return this portion with a check or money order made payable to Gas South. Please do not send cash.

If address has changed, please check here and complete the information on the back of the remittance slip.

Account Number: 1507180292

Total Amount Due \$563.37

Amount Enclosed

\$563.37 will be automatically deducted from your bank account.

GAS SOUTH
PO BOX 530552
ATLANTA GA 30353-0552

MB 01 001577 91970 H 6 B



HARBOR BAY CDD GASLIGHTS
3434 COLWELL AVE STE 200
TAMPA FL 33614-8390

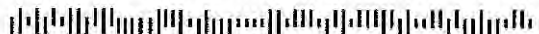

0 20260219 3 15071802928 0 00000000000000 0 0000000056337 1 5



Paying Your Bill

AutoPay

Visit GasSouth.com/pay to set up automatic payment so you can pay your bill every month on the due date with NO transaction fees!

Payments Accepted: Checking Account

Pay By Mail

Gas South
PO Box 530552
Atlanta, GA 30353

Payments Accepted: Check/Money Order

Please include remittance slip and allow 5-7 business days for payment to process.

Pay By ACH

Gas South's bank routing number is 021052053 and bank account number is 81751527. If you have questions regarding ACH, please contact AFT@GasSouth.com.

Pay Online

Visit GasSouth.com/pay to make a one-time payment.

Payments Accepted: Checking Account, Credit/Debit/ATM Card

Pay By Phone

Call 877-596-5072 to pay your bill by phone.

Payments Accepted: Checking Account, Credit/Debit/ATM Card

Understanding Your Bill

Gas Charges: Cost of gas used during the billing period that is calculated by multiplying your therms used by your rate per therm.

Therms Used: Measurement of gas you used.

Rate Per Therm: Price you pay for each therm used.

Thermal Factor: Used to obtain a measurement of energy in therms.

CCFs Used: Measurement of gas used in hundreds of cubic feet.

Customer Service Fee: Fee for maintaining your account that includes the cost of generating and mailing your bill, customer service and other account maintenance functions.

Rate Plan: Indicates whether you are on a fixed, nymex or index contract.

Transport Fuel Charges: Transportation-related fuel charge.

Transportation: Charge to cover the cost of capacity needed to transport your gas.

Municipal Tax: Tax required by the local municipal in your area.

Additional Information

Delinquent Bills and Late Fees: Balances paid after the due date incur a late penalty of \$10 or 15%, whichever is greater. Customers may face further action, such as disconnection of their gas service and negative impact to their credit, if insufficient payment is made.

Fixed Rate Plan: Fixed rate customers changing or canceling their contract prior to the contract end date will be charged an early contract cancellation fee. Customers who do not renew their contract at the end of their term will default to a monthly commercial variable rate.

Questions? Concerns? Contact Gas South at 866-426-2491, BizRelations@GasSouth.com, or PO Box 723728, Atlanta GA 31139-99419.

Copyright © 2024 Gas South

Mailing Address Change

This is a scannable document. To help us make the correct changes to your account, please print clearly and stay within the boxes.

MR. MS.

Name:

Address:

City: State: ZIP:

Primary Phone: --

Phone Type: Mobile Landline
(choose one)

Email:



The Difference is Good.

HARBOR BAY CDD GASLIGHTS
0 MIRABAY BLVD
APOLLO BEACH FL 33572-0000

Bill Date: 01/30/26
Plan: Florida Index Zone 3

Pay Online: GasSouth.com/pay

Message Center (cont.)

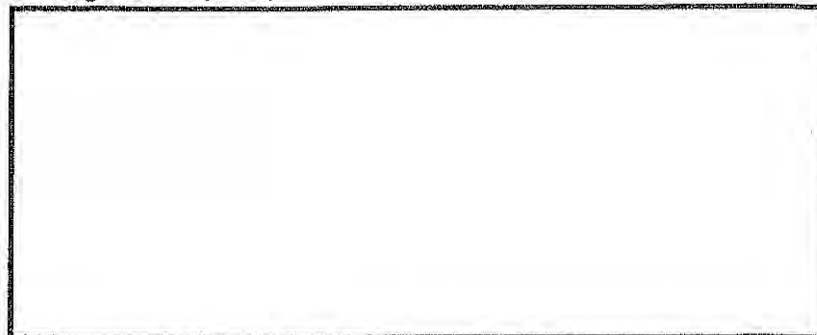

Local Distributor: Peoples Gas System Emergencies or Leaks: 877.832.6747 Gas South Customer Care: 866.426.2491 | BizRelations@GasSouth.com

How We Calculated Your Gas Charges (LDC Number:211009425268)

Meter Start	Meter End	Days of Service	Therms Used		Rate per Therm		Gas Charges
12/27/2025	12/31/2025	5	117.98	X	0.5690	=	67.13
01/01/2026	01/26/2026	26	613.52	X	0.6060	=	371.79
12/27/2025	01/26/2026	31	731.50		Total	=	438.92

001577 2/2





GoTo Communications, Inc.

INVOICE

Invoice Date 02/01/2026
Invoice # IN7104936766
PO #
Customer ID CN-520144-2005
Terms **AutoPay Scheduled**
Due Date 02/16/2026
Currency US Dollar

Your automatic payment is scheduled to be processed around the 10th of the month

Bill To

HARBOR BAY CDD
 3434 COLWELL AVE.
 SUITE 200
 TAMPA FL 33614
 UNITED STATES

INVOICE Total:\$236.91

Amount Due:\$236.91

Billing Group	Description	Quantity	Rate	Amount
Primary	GoToConnect - Monthly Service Charge 02/01/2026 - 02/28/2026	10	17.95	\$179.50
Primary	Conference Device - Monthly Service Charge 02/01/2026 - 02/28/2026	1	17.95	\$17.95
Primary	Standard Phone Numbers (DID) 02/01/2026 - 02/28/2026	5	0.5	\$2.50
Primary	Included minutes in plan 01/01/2026 - 01/31/2026	345.5	0	\$0.00
Primary	SMS Compliance - Monthly Campaign - Low Usage 02/01/2026 - 02/28/2026	1	1.5	\$1.50
Primary	State and Local Regulatory Recovery Fee	1	16.24	\$16.24
Primary	Universal Service Fee (USF)	1	7.4542	\$7.45
Primary	Cost Recovery Fee	1	11.7707	\$11.77

Total **\$236.91**

Your automatic payment is scheduled to be processed around the 10th of the month

View and Pay your invoices online: <https://admin.goto.com/gtc-billing>
 Billing Support: <https://support.goto.com/connect/billing-user-guide>



GoTo Communications, Inc.

INVOICE

Invoice Date	02/01/2026
Invoice #	IN7104936766
PO #	
Customer ID	CN-520144-2005
Terms	AutoPay Scheduled
Due Date	02/16/2026
Currency	US Dollar

Your automatic payment is scheduled to be processed around the 10th of the month

Online Payment Options:

Please visit <https://admin.goto.com/gtc-billing> to view and download your invoices, search and download billed call details, setup or edit AutoPay as well as manage your invoice delivery recipients. *Ability to access this option may require 'view/pay invoice' permissions be granted by your super admin & may not be available to certain reseller customers.

*Certain audio Services are provided by the applicable [GoTo affiliate](#) who sets the rates, terms, and conditions for audio services. GoTo Technologies USA, Inc. presents this invoice and collects on behalf of the applicable GoTo affiliate as its agent.

*Telecom fees (incl. USF and Regulatory Recovery Fees) are only applicable to GoToConnect, and OpenVoice Services. If you'd like to know more about how GoTo currently displays fees on your invoice, please visit [here](#).

*Connect Bundle is comprised of GoToConnect and GoToMeeting Pro. GoToConnect is provided by GoTo Communications, Inc.

Hanley Pools LLC
Po Box 6004
Sun City Center, FL 33571
8139409875
info@hanleypools.com

Date- 02-20-26

GL Code- 572004833

Approved by- [Signature]



BILL TO
Mira Bay
Harbor Bay Community
Development District C/o Rizzetta
& Company
Harbor Bay CDD
107 Mann Harbor Dr.
Apollo Beach, FL 33572
United States

INVOICE 1307

DATE 02/20/2026 **TERMS** Due on receipt

DUE DATE 02/20/2026

DESCRIPTION	AMOUNT
Proposal to NO. Mirabay Replace mechanical sand filters	1,250.00

If paying by debit or credit card there is a 3.5% convenience fee charge, you can call us, pay online or call 813-839-7665 during business hours. Zelle to 813-940-9875
If paying by check:
Make checks payable to: Hanley Pools LLC Mail to Po Box 6004, Sun City Center, 33571

SUBTOTAL	1,250.00
TAX	0.00
TOTAL	1,250.00

TOTAL DUE \$1,250.00

Ways to pay

BANK

[View and pay](#)

NOTICE OF TERMS: All past due amounts are subject to a monthly late charge of 5% PLUS all cost of collections and reasonable Attorney fees

INVOICE

HECKER CONSTRUCTION CO.
INC.
PO Box 989
Ruskin, FL 33575-0989

Heckercompany@aol.com
+1 (813) 236-9306
www.heckerconstruction.com



Bill to
Harbor Bay Community Development
District
C/O Rizzetta & Company
3434 Colwell Avenue Suite #200
Tampa, FL 33614 United States

Invoice details

Sales Rep: EMS

Invoice no.: 7882
Terms: Net 10
Invoice date: 02/09/2026
Due date: 02/19/2026

#	Product or service	Description	Amount
1.	Services	1. Permitting with E.P.C. and A.C.O.E. not needed	\$0.00
2.	Services	2. Dig out existing voids along seawall. Install filter fabric and back fill voids with crushed concrete and dirt back-fill.	\$0.00
3.	Services	3. Install new cut out pieces of composite seawall sheets and screw to existing seawall and caulk with 5200 marine adhesives.	\$0.00
4.	Proposal Residential	Total cost of work above.	\$2,500.00
5.		Job Location: 1088 Signet Drive, Apollo Beach, FL 33572	
Total			\$2,500.00



Hillsborough County Florida

CUSTOMER NAME	ACCOUNT NUMBER	BILL DATE	DUE DATE
HARBOR BAY COMMUNITY DEVELOPMENT DISTRICT	1779718759	01/21/2026	02/11/2026

Service Address: 5248 ADMIRAL POINTE DR

Page 1 of 1

METER NUMBER	PREVIOUS DATE	PREVIOUS READ	PRESENT DATE	PRESENT READ	CONSUMPTION	READ TYPE	METER DESCRIPTION
60886873	12/16/2025	15180	01/20/2026	15416	23600 GAL	ACTUAL	WATER

Service Address Charges

Customer Service Charge	\$6.54
Purchase Water Pass-Thru	\$71.27
Water Base Charge	\$47.39
Water Usage Charge	\$38.54
Sewer Base Charge	\$114.80
Sewer Usage Charge	\$166.85

Summary of Account Charges

Previous Balance	\$334.65
Net Payments - Thank You	\$-334.65
Total Account Charges	\$445.39
AMOUNT DUE	\$445.39

Important Message

This account has ACH payment method

Notice

* DO NOT PAY * YOU ARE ENROLLED IN OUR AUTO PAY PROGRAM. THE TOTAL AMOUNT OF THIS BILL WILL BE DEDUCTED FROM YOUR BANK ACCOUNT 7 DAYS FROM THE BILLING DATE. IF YOU HAVE A DISPUTE, PLEASE CALL (813) 272-6680 PRIOR TO THAT DATE.

Consumption History

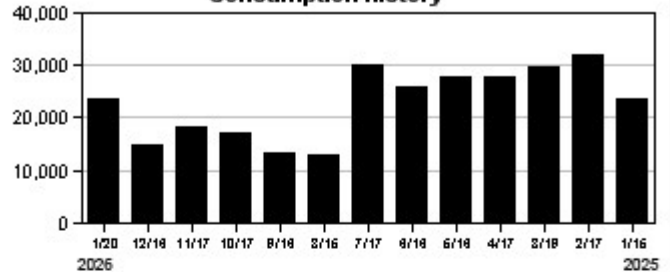

Hillsborough County Florida

Make checks payable to: **BOCC**

ACCOUNT NUMBER: 1779718759



ELECTRONIC PAYMENTS BY CHECK OR

Automated Payment Line: (813) 307-1000
Internet Payments: HCFL.gov/WaterBill
Additional Information: HCFL.gov/Water



THANK YOU!

DUE DATE	02/11/2026
Auto Pay Scheduled DO NOT PAY	

HARBOR BAY COMMUNITY DEVELOPMENT DISTRICT
4530 EAGLE FALLS PLACE
TAMPA FL 33619

3731 0

0017797187592 00000445395





Hillsborough County Florida

CUSTOMER NAME	ACCOUNT NUMBER	BILL DATE	DUE DATE
HARBOR BAY CDD	4432900000	01/21/2026	02/11/2026

Service Address: 751 MANN'S HARBOR DR I

Page 1 of 1

METER NUMBER	PREVIOUS DATE	PREVIOUS READ	PRESENT DATE	PRESENT READ	CONSUMPTION	READ TYPE	METER DESCRIPTION
703608940	12/18/2025	612288	01/19/2026	632437	20149 GAL	ACTUAL	WATER

Service Address Charges

Customer Service Charge	\$6.54
Purchase Water Pass-Thru	\$60.85
Water Base Charge	\$19.01
Water Usage Charge	\$48.47

Summary of Account Charges

Previous Balance	\$95.25
Net Payments - Thank You	\$-95.25
Total Account Charges	\$134.87
AMOUNT DUE	\$134.87

Important Message

This account has ACH payment method

Notice

* DO NOT PAY * YOU ARE ENROLLED IN OUR AUTO PAY PROGRAM. THE TOTAL AMOUNT OF THIS BILL WILL BE DEDUCTED FROM YOUR BANK ACCOUNT 7 DAYS FROM THE BILLING DATE. IF YOU HAVE A DISPUTE, PLEASE CALL (813) 272-6680 PRIOR TO THAT DATE.

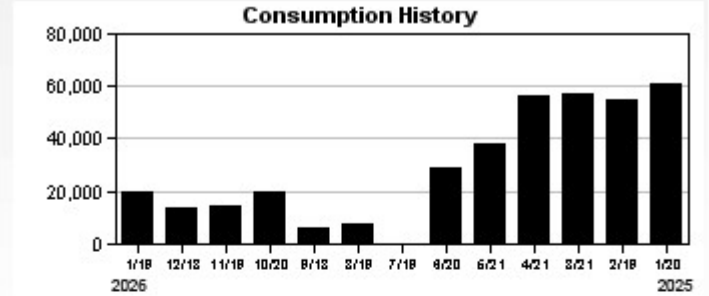

Hillsborough County Florida

Make checks payable to: **BOCC**

ACCOUNT NUMBER: 4432900000



ELECTRONIC PAYMENTS BY CHECK OR

Automated Payment Line: (813) 307-1000
 Internet Payments: HCFL.gov/WaterBill
 Additional Information: HCFL.gov/Water

THANK YOU!

HARBOR BAY CDD
4530 EAGLE FALLS PLACE
TAMPA FL 33619

9,118 0

DUE DATE	02/11/2026
Auto Pay Scheduled DO NOT PAY	



0044329000002 00000134874



Hillsborough County Florida

CUSTOMER NAME	ACCOUNT NUMBER	BILL DATE	DUE DATE
HARBOR BAY CDD	5432900000	01/21/2026	02/11/2026

Service Address: 5325 FISHERSOUND LN I

Page 1 of 1

METER NUMBER	PREVIOUS DATE	PREVIOUS READ	PRESENT DATE	PRESENT READ	CONSUMPTION	READ TYPE	METER DESCRIPTION
703605030	12/18/2025	83702	01/21/2026	114651	30949 GAL	ACTUAL	WATER

Service Address Charges

Customer Service Charge	\$6.54
Purchase Water Pass-Thru	\$93.47
Water Base Charge	\$13.58
Water Usage Charge	\$121.69

Summary of Account Charges

Previous Balance	\$50.25
Net Payments - Thank You	\$-50.25
Total Account Charges	\$235.28
AMOUNT DUE	\$235.28

Important Message

This account has ACH payment method

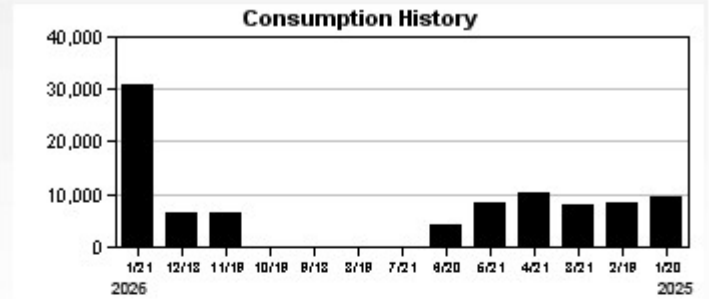

Hillsborough County Florida

Make checks payable to: **BOCC**

ACCOUNT NUMBER: 5432900000



ELECTRONIC PAYMENTS BY CHECK OR

Automated Payment Line: (813) 307-1000
 Internet Payments: HCFL.gov/WaterBill
 Additional Information: HCFL.gov/Water

THANK YOU!

"Single Piece"
HARBOR BAY CDD
4530 EAGLE FALLS PLACE
TAMPA FL 33619

11,1458

DUE DATE	02/11/2026
AMOUNT DUE	\$235.28
AMOUNT PAID	



0054329000001 00000235283



Hillsborough County Florida

CUSTOMER NAME	ACCOUNT NUMBER	BILL DATE	DUE DATE
HARBOR BAY CDD	6542900000	01/21/2026	02/11/2026

Service Address: 5231 POINT HARBOR LN I

Page 1 of 1

METER NUMBER	PREVIOUS DATE	PREVIOUS READ	PRESENT DATE	PRESENT READ	CONSUMPTION	READ TYPE	METER DESCRIPTION
702856050	12/18/2025	199386	01/21/2026	211702	12316 GAL	ACTUAL	WATER

Service Address Charges

Customer Service Charge	\$6.54
Purchase Water Pass-Thru	\$37.19
Water Base Charge	\$13.58
Water Usage Charge	\$28.21

Summary of Account Charges

Previous Balance	\$72.93
Net Payments - Thank You	\$-72.93
Total Account Charges	\$85.52
AMOUNT DUE	\$85.52

Important Message

This account has ACH payment method

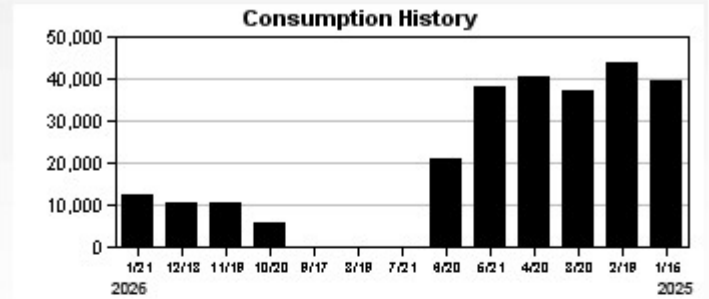

Hillsborough County Florida

Make checks payable to: **BOCC**

ACCOUNT NUMBER: 6542900000



ELECTRONIC PAYMENTS BY CHECK OR

Automated Payment Line: (813) 307-1000
 Internet Payments: HCFL.gov/WaterBill
 Additional Information: HCFL.gov/Water

THANK YOU!

HARBOR BAY CDD
4530 EAGLE FALLS PLACE
TAMPA FL 33619

13,5048

DUE DATE	02/11/2026
AMOUNT DUE	\$85.52
AMOUNT PAID	



0065429000006 00000085522



Hillsborough County Florida

CUSTOMER NAME	ACCOUNT NUMBER	BILL DATE	DUE DATE
HARBOR BAY CDD	7788800000	01/21/2026	02/11/2026

Service Address: 736 MANNS HARBOR DR I

Page 1 of 1

METER NUMBER	PREVIOUS DATE	PREVIOUS READ	PRESENT DATE	PRESENT READ	CONSUMPTION	READ TYPE	METER DESCRIPTION
703608094	12/18/2025	598883	01/21/2026	669790	70907 GAL	ACTUAL	WATER

Service Address Charges

Customer Service Charge	\$6.54
Purchase Water Pass-Thru	\$214.14
Water Base Charge	\$63.42
Water Usage Charge	\$174.90

Summary of Account Charges

Previous Balance	\$69.96
Net Payments - Thank You	\$-69.96
Total Account Charges	\$459.00
AMOUNT DUE	\$459.00

Important Message

This account has ACH payment method

Notice

* DO NOT PAY * YOU ARE ENROLLED IN OUR AUTO PAY PROGRAM. THE TOTAL AMOUNT OF THIS BILL WILL BE DEDUCTED FROM YOUR BANK ACCOUNT 7 DAYS FROM THE BILLING DATE. IF YOU HAVE A DISPUTE, PLEASE CALL (813) 272-6680 PRIOR TO THAT DATE.

Consumption History

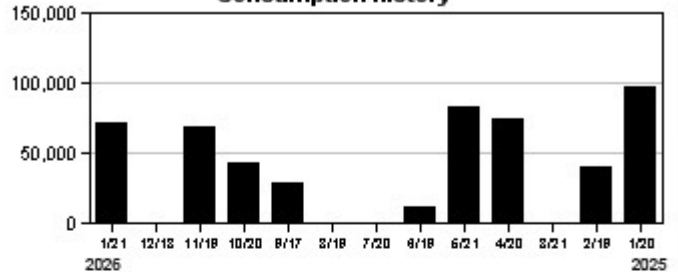

Hillsborough County Florida

Make checks payable to: **BOCC**

ACCOUNT NUMBER: 7788800000



ELECTRONIC PAYMENTS BY CHECK OR

Automated Payment Line: (813) 307-1000
Internet Payments: HCFL.gov/WaterBill
Additional Information: HCFL.gov/Water



THANK YOU!

DUE DATE	02/11/2026
Auto Pay Scheduled DO NOT PAY	

"Single Piece"
HARBOR BAY CDD
4530 EAGLE FALLS PLACE
TAMPA FL 33619

16,052 0

0077888000005 00000459008





Hillsborough County Florida

CUSTOMER NAME	ACCOUNT NUMBER	BILL DATE	DUE DATE
HARBOR BAY CDD	9406800000	01/21/2026	02/11/2026

Service Address: 107 MANNS HARBOR DR

Page 1 of 1

METER NUMBER	PREVIOUS DATE	PREVIOUS READ	PRESENT DATE	PRESENT READ	CONSUMPTION	READ TYPE	METER DESCRIPTION
705841002	12/18/2025	90471	01/21/2026	111141	206700 GAL	ACTUAL	WATER

Service Address Charges

Customer Service Charge	\$6.54
Purchase Water Pass-Thru	\$624.23
Water Base Charge	\$232.63
Water Usage Charge	\$469.97
Sewer Base Charge	\$563.90
Sewer Usage Charge	\$1,461.37

Summary of Account Charges

Previous Balance	\$2,610.15
Net Payments - Thank You	\$-2,610.15
Total Account Charges	\$3,358.64
AMOUNT DUE	\$3,358.64

Important Message

This account has ACH payment method

Notice

* DO NOT PAY * YOU ARE ENROLLED IN OUR AUTO PAY PROGRAM. THE TOTAL AMOUNT OF THIS BILL WILL BE DEDUCTED FROM YOUR BANK ACCOUNT 7 DAYS FROM THE BILLING DATE. IF YOU HAVE A DISPUTE, PLEASE CALL (813) 272-6680 PRIOR TO THAT DATE.

Consumption History

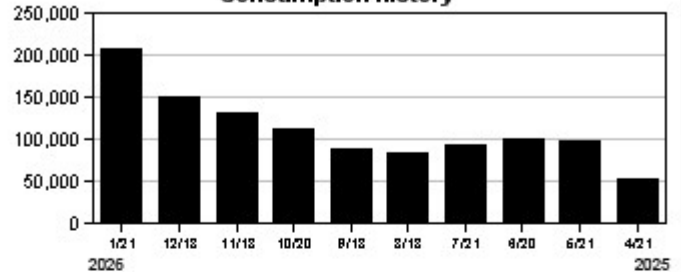

Hillsborough County Florida

Make checks payable to: **BOCC**

ACCOUNT NUMBER: 9406800000



ELECTRONIC PAYMENTS BY CHECK OR

Automated Payment Line: (813) 307-1000
Internet Payments: HCFL.gov/WaterBill
Additional Information: HCFL.gov/Water



THANK YOU!

DUE DATE 02/11/2026

**Auto Pay Scheduled
DO NOT PAY**

"Single Place"
HARBOR BAY CDD
4530 EAGLE FALLS PLACE
TAMPA FL 33619

19,540

0094068000002 00003358645



Lee Te Kim Lawn Care & Nursery

127 16th Avenue SW
Ruskin, FL 33570

Invoice

Date	Invoice #
2/3/2026	FEB 06853

Bill To
HARBOR BAY COMMUNITY DEVELOPMENT DISTRICT C/O RIZZETTA & COMPANY 3434 COLWELL AVENUE, SUITE 200 TAMPA, FL 33614

P.O. No.	Terms	Project
MIRABAY 06853	Due on receipt	

Quantity	Description	Rate	Amount
	PALM HEALTH CARE TREATMENT: / INJECTIONS: (220) DATE PALMS & RECLINATA PALMS - LARGE STEM (81) BISMARCK PALMS (1) CANARY ISLAND DATE PALM OTC ANTIBIOTIC INJECTION - QUARTERLY EMAMECTIN INSECTICIDE INJECTIONS - BIANNUALLY INSPECTION & RECOMMENDATIONS - QUARTERLY	6,174.00	6,174.00
		Total	\$6,174.00

Lee Te Kim Lawn Care & Nursery

127 16th Avenue SW
 Ruskin, FL 33570

Invoice

Date	Invoice #
1/30/2026	JAN 06846

Bill To
HARBOR BAY COMMUNITY DEVELOPMENT DISTRICT C/O RIZZETTA & COMPANY 3434 COLWELL AVENUE, SUITE 200 TAMPA, FL 33614

P.O. No.	Terms	Project
MIRABAY 06846	Due on receipt	

Quantity	Description	Rate	Amount
	FISHERSOUND ROUDABOUT / IRRIGATION REPAIRS REPLACE (1) NODE (2) BATTERIES	358.27	358.27
	CLOCK A ZONES 18,19,21 & 22 - REPAIR WIRES THAT WERE CUT & SHORTED OUT REPLACE (3) ROTORS REPLACE (7) HEADS REPLACE (3) NOZZLES	657.69	657.69
	CLOCK B ZONE 2 - REPAIR VALVE THAT WOULDN'T SHUT OFF	80.00	80.00
	MANNS HARBOR ZONE 20 - REPLACE (1) SOLENOID REPAIR SPLICES IN DRIP LINES	503.88	503.88
	PUMP A REPLACE (1) NODE (2) BATTERIES	358.27	358.27
	MANNS HARBOR ROYALS REPLACE & REWIRE DIAPHRAGM REPLACE (1) SOLENOID	583.88	583.88
	MIRABAY BLVD. REPLACE (2) SOLENOIDS	847.76	847.76
	MIRABAY BLVD. ROUNDABOUT ZONE 3, REPLACE (1) SOLENOID REPLACE (1) NODE	762.15	762.15
		Total	

Lee Te Kim Lawn Care & Nursery

127 16th Avenue SW
 Ruskin, FL 33570

Invoice

Date	Invoice #
1/30/2026	JAN 06846

Bill To
HARBOR BAY COMMUNITY DEVELOPMENT DISTRICT C/O RIZZETTA & COMPANY 3434 COLWELL AVENUE, SUITE 200 TAMPA, FL 33614

P.O. No.	Terms	Project
MIRABAY 06846	Due on receipt	

Quantity	Description	Rate	Amount
	MERRITT ISLAND REPLACE (1) NODE REPLACE (2) BATTERIES	283.00	283.00
	CLUBHOUSE REPLACE (1) NODE REPLACE (3) LATCHING SOLENOIDS	648.27	648.27
	ISLEBAY / T-7 ROUNDABOUT REPLACE (1) NODE REPLACE (2) BATTERIES	283.00	283.00
	PINCKNEY ROUNDABOUT INSTALL SHORTER EXTENSION SPRAYER HEAD REPLACE (2) HEADS REPLACE (2) BATTERIES	173.34	173.34
	SEA CREST REPLACE (1) SPRAYER	20.00	20.00
	TORTOISE / ISLEBAY REPLACE (1) SPRAYER	20.00	20.00
	TYBEE ISLAND ROUNDABOUT REPLACE (2) BATTERIES	30.00	30.00
	WOLF CREEK PARK RESET CLOCK - SOMEONE TURNED OFF REPLACE (1) BREAKER REPLACE (4) SOLENOIDS ZONES 5 & 6 - REPAIR WIRES & REPLACE CONNECTORS	2,085.52	2,085.52
		Total	\$7,695.03

Lee Te Kim Lawn Care & Nursery

127 16th Avenue SW
Ruskin, FL 33570

Invoice

Date	Invoice #
1/31/2026	JAN 06847

Bill To
HARBOR BAY COMMUNITY DEVELOPMENT DISTRICT C/O RIZZETTA & COMPANY 3434 COLWELL AVENUE, SUITE 200 TAMPA, FL 33614

P.O. No.	Terms	Project
MIRABAY 06847	Due on receipt	

Quantity	Description	Rate	Amount
	LANDSCAPE MAINTENANCE FOR JANUARY 2026	41,166.66	41,166.66
		Total	\$41,166.66

Lee Te Kim Lawn Care & Nursery

127 16th Avenue SW
Ruskin, FL 33570

Invoice

Date	Invoice #
1/31/2026	JAN 06848

Bill To
HARBOR BAY COMMUNITY DEVELOPMENT DISTRICT C/O RIZZETTA & COMPANY 3434 COLWELL AVENUE, SUITE 200 TAMPA, FL 33614

P.O. No.	Terms	Project
MIRABAY 06848	Due on receipt	

Quantity	Description	Rate	Amount
	WATER USE PERMIT REPORTING FOR JANUARY 2026	500.00	500.00
		Total	\$500.00

Lee Te Kim Lawn Care & Nursery

127 16th Avenue SW
Ruskin, FL 33570

Invoice

Date	Invoice #
1/31/2026	JAN 06849

Bill To
HARBOR BAY COMMUNITY DEVELOPMENT DISTRICT C/O RIZZETTA & COMPANY 3434 COLWELL AVENUE, SUITE 200 TAMPA, FL 33614

P.O. No.	Terms	Project
MIRABAY 06849	Due on receipt	

Quantity	Description	Rate	Amount
	TURFGRASS MANAGEMENT FOR JANUARY 2026	23,601.67	23,601.67
		Total	\$23,601.67

Lee Te Kim Lawn Care & Nursery

127 16th Avenue SW
Ruskin, FL 33570

Invoice

Date	Invoice #
1/31/2026	JAN 06850

Bill To
HARBOR BAY COMMUNITY DEVELOPMENT DISTRICT C/O RIZZETTA & COMPANY 3434 COLWELL AVENUE, SUITE 200 TAMPA, FL 33614

P.O. No.	Terms	Project
MIRABAY 06850	Due on receipt	

Quantity	Description	Rate	Amount
	IRRIGATION MANAGEMENT AND MAINTENANCE FOR JANUARY 2026	5,166.67	5,166.67
		Total	\$5,166.67

Lee Te Kim Lawn Care & Nursery

127 16th Avenue SW
Ruskin, FL 33570

Invoice

Date	Invoice #
1/31/2026	JAN 06851

Bill To
HARBOR BAY COMMUNITY DEVELOPMENT DISTRICT C/O RIZZETTA & COMPANY 3434 COLWELL AVENUE, SUITE 200 TAMPA, FL 33614

P.O. No.	Terms	Project
MIRABAY 06851	Due on receipt	

Quantity	Description	Rate	Amount
	MAINTENANCE OF THE (11) CONVEYED PARK SQUARE FOLIOS FOR JANUARY 2026	15,000.00	15,000.00
		Total	\$15,000.00



Lighthouse Engineering Inc.
701 Enterprise Road East
Suite 410
Safety Harbor, FL 34695
727-726-7856

Harbor Bay Community Development District
c/o Rizzetta & Company
3434 Colwell Avenue, Suite 200
Tampa, FL 33614

Invoice number 33
Date 02/03/2026

Project **Harbor Bay CDD**

Lighthouse Engineering, Inc.

Send invoices via email to: cddinvoice@rizzetta.com

Invoice Summary

Description	Total Billed	Prior Billed	Current Billed
DOCK AND LIFT APPLICATIONS	8,050.00	8,050.00	0.00
PICKLEBALL TROUBLESHOOTING	3,597.50	3,597.50	0.00
ROADWAY ANALYSIS	38,490.00	36,215.00	2,275.00
GENERAL ENGINEERING CONSULTING AT-REQUEST	285,177.50	281,727.50	3,450.00
Total	335,315.00	329,590.00	5,725.00

Roadway Analysis

Professional Fees

	Hours	Rate	Billed Amount
Project Manager			
Thomas Liu			
Project Chargeable Labor	13.00	175.00	2,275.00

General Engineering Consulting At-Request

Professional Fees

	Hours	Rate	Billed Amount
CADD Technician			
Amy L. Palmer			
Operations Manager	23.00	150.00	3,450.00

Invoice total	5,725.00
---------------	-----------------

Aging Summary

Invoice Number	Invoice Date	Outstanding	Current	Over 30	Over 60	Over 90	Over 120
32	01/06/2026	5,875.00	5,875.00				
33	02/03/2026	5,725.00	5,725.00				
	Total	11,600.00	11,600.00	0.00	0.00	0.00	0.00

Approved by:

Bradley S. Foran
 P.E., Principal / Owner

*Please remit to: 701 Enterprise Road, Suite 410, Safety Harbor, FL 34695
 For questions about this invoice, please call Brad Foran at 727-726-7856*

Invoice Supporting Detail

**220200105 Harbor Bay CDD
 Dock and Lift Applications**

Phase Status: Active

Billing Cutoff: 01/31/2026

WIP Status:

Date	Units	Rate	Amount
Subtotal			0.00
total			0.00

Pickleball Troubleshooting

Phase Status: Active

Billing Cutoff: 01/31/2026

WIP Status:

Date	Units	Rate	Amount
Subtotal			0.00
total			0.00

Roadway Analysis

Phase Status: Active

Billing Cutoff: 01/31/2026

Labor

WIP Status: Billable

Project Manager

Thomas Liu

Date	Units	Rate	Amount
01/05/2026	4.00	175.00	700.00
<i>Harbor Bay CDD - Roadway Plans (exist./prop. ditch profiles)</i>			
01/06/2026	5.00	175.00	875.00
<i>Harbor Bay CDD - Roadway Plans (exist./prop. ditch profiles)</i>			
01/08/2026	1.00	175.00	175.00
<i>Harbor Bay CDD (US Hwy. 41 ditch regrade) - Coordination with contractor, plans</i>			
01/09/2026	2.00	175.00	350.00
<i>Harbor Bay CDD (US Hwy. 41 ditch regrade) - Create app. to SWFWMD (Permit Exemption Request)</i>			
01/15/2026	1.00	175.00	175.00
<i>Harbor Bay CDD - Exist. pipe size identification (Manns Harbor & Isle Bay Dr.)</i>			
Subtotal		13.00	2,275.00
Labor total		13.00	2,275.00

220200105 General Engineering Consulting At-Request

Phase Status: Active

Billing Cutoff: 01/31/2026

Labor

WIP Status: Billable

CADD Technician

Amy L. Palmer

Date	Units	Rate	Amount
01/02/2026	1.00	150.00	150.00
<i>Email catch-up</i>			
01/05/2026	1.00	150.00	150.00
<i>Email grading contract camera work quotes</i>			
01/06/2026	1.00	150.00	150.00

Invoice Supporting Detail

220200105 Harbor Bay CDD

220200105 General Engineering Consulting At-Request

Phase Status: Active

Billing Cutoff: 01/31/2026

Date	Units	Rate	Amount
------	-------	------	--------

Labor

WIP Status: Billable

CADD Technician

Amy L. Palmer

Email

Grading Contract questions

Operations Manager	01/07/2026	1.00	150.00	150.00
--------------------	------------	------	--------	--------

Email

Map for camera work

SWFWMD permitting for grading work

Operations Manager	01/08/2026	1.00	150.00	150.00
--------------------	------------	------	--------	--------

Roofing Contract

Email follow up

Operations Manager	01/09/2026	1.00	150.00	150.00
--------------------	------------	------	--------	--------

Obtain quotes for pipe camera inspection and create map

Operations Manager	01/12/2026	1.00	150.00	150.00
--------------------	------------	------	--------	--------

Meeting with Blue Works about camera work - plans search

Operations Manager	01/14/2026	1.50	150.00	225.00
--------------------	------------	------	--------	--------

Meeting with Council to discuss PS conveyance

Email correspondence

Operations Manager	01/15/2026	4.50	150.00	675.00
--------------------	------------	------	--------	--------

Meeting prep

Emails

CDD Board Meeting

Operations Manager	01/16/2026	1.00	150.00	150.00
--------------------	------------	------	--------	--------

Meeting follow up items

email

Operations Manager	01/20/2026	0.50	150.00	75.00
--------------------	------------	------	--------	-------

Email

Operations Manager	01/21/2026	0.50	150.00	75.00
--------------------	------------	------	--------	-------

Email

Operations Manager	01/23/2026	2.00	150.00	300.00
--------------------	------------	------	--------	--------

Review videos of damage to Marisol Point

Email

Operations Manager	01/26/2026	0.50	150.00	75.00
--------------------	------------	------	--------	-------

email

Operations Manager	01/27/2026	0.50	150.00	75.00
--------------------	------------	------	--------	-------

Email

Operations Manager	01/28/2026	4.00	150.00	600.00
--------------------	------------	------	--------	--------

Site Visit - Marisol Point

Skimmer Dr. Erosion

Operations Manager	01/29/2026	1.00	150.00	150.00
--------------------	------------	------	--------	--------

Email

Follow up action items from site visit

Subtotal		23.00		3,450.00
----------	--	--------------	--	-----------------

Labor total		23.00		3,450.00
-------------	--	--------------	--	-----------------

Invoice Supporting Detail

Invoice Summary

	Contract	Billed	%	Remaining	%
Labor		335,315.00		-335,315.00	
Expense					
Consultant					
Total		335,315.00		-335,315.00	



MAIN GATE ENTERPRISES INC

Invoice

240 Stenstrom Rd
Wauchula, FL 33873

Date	Invoice #
1/20/2026	37055

Bill To
Harbor Bay Community Development District C/o Rizzetta & Company 3434 Colwell Avenue, Suite 200 Tampa, Florida 33614

Phone #	E-mail
863-773-3066	ACCOUNTING@MAIN-GATES.COM

Terms	Due Date
Due on receipt	1/20/2026

Description	Qty	Rate	Amount
01-26-2026 SERVICE CALL - MIRA BAY PER JOEL THEY ARE HAVING ISSUES AT THE ADMIRAL POINT GATELINE Technician arrived on site and, after testing through the operator, found that the loop detector had tripped. The technician reset the loop detector; however, it tripped again. Further testing revealed that one of the wires coming from the loop was not making proper contact. The connection was repaired, the system was tested, and everything is now operational and functioning properly again.			
TRIP CHARGE	1	100.00	100.00
HRS OF LABOR	1	125.00	125.00
Date- <u>02-03-26</u>			
GL Code- <u>529004612</u>			
Approved by- <u>JN</u>			

Accounts past due will be subject to a monthly 1.5% finance charge (18% annual) with a minimum charge of \$5.00. All invoices paid with credit or debit card will have an additional 2.9% fee added.

Subtotal	\$225.00
Sales Tax (7.0%)	\$0.00
Total	\$225.00
Payments/Credits	\$0.00
Balance Due	\$225.00

We would greatly appreciate if you call 863-773-3066 or send an e-mail to servicedept@main-gates.com for all service related issues. This is to ensure that your call is timely dispatched. We cannot guarantee that calls directly to technicians will be dispatched and completed in a timely manner. We appreciate your business and understanding.

HARBOR BAY COMMUNITY DEVELOPMENT DISTRICT

District Office – Wesley Chapel, Florida (813) 994-1001
Mailing Address – 3434 Colwell Avenue Suite 200, Tampa, Florida 33614
www.harborbaycdd.org

Check Request

Amount: \$110.11

Date: 02/17/26

Payable to: Meredith Shreve

Address: 5314 Loon NesCourt
Apollo Beach, FL 33572

Description: Reimbursement for Christmas Decorations

Requestor: Venessa Smith

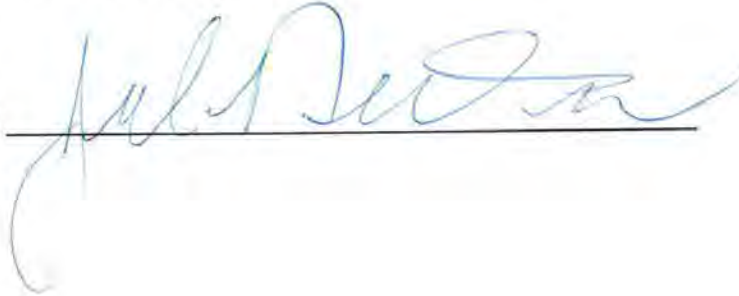
Approved: 

110.11
+ 2/27
114.38 Michael's

Everything to create anything

MICHAEL'S STORE #9568 (813)653-9300
 AGENCY SQUARE SHOPS CTR
 2564 W BRANNON BLVD
 BRANDBLUM, FL 33511-4719
 Rewards Number: 141-110682243



PRICE 1366.9568 010 10/17/25 12 95
 QTY 1 12.00/73386976 14.99
 3 @ 7.49 22.47
 YOU SAVED \$ 22.50
 SUBTOTAL 102.43
 Sales Tax 7.5% 7.68
 TOTAL 110.11

RECEIVED BY: *****110.11
 MICHAEL'S CARD
 CONTACTLESS
 CARD NUMBER: 000000041010
 EXPIRES: 0000008201

This receipt expires at 60 days on 12/15/25
 Previous Michaels Rewards Balance: \$0.27
 Click Buy to date Shop michaels.com today
 Savings & Inspiration! Text #SIGNUP to
 To Sign Up for Email & Text Messages
 *Msg & Data Rates May Apply
 You will receive 1 autodialed message
 with a link to join Michaels alerts.

THANK YOU FOR SHOPPING AT MICHAEL'S
 11/27/2025 11:02 AM
 Final sale
 Not valid for refund or exchange

Dear Valued Customer,
 Please see return and coupon policies on
 michaels.com and in store at receipt
 10/17/25 12 95

HARBOR BAY COMMUNITY DEVELOPMENT DISTRICT

District Office – Wesley Chapel, Florida (813) 994-1001
Mailing Address – 3434 Colwell Avenue Suite 200, Tampa, Florida 33614
www.harborbaycdd.org

Check Request

Amount: \$79.00

Date: 01/31/26

Payable to: Michael Rodriguez

Address: 420 Manns Harbor Drive
Apollo Beach, FL 33572

Description: Reimbursement for Ethics Course 12/25

Requestor: Venessa Smith

Receipt Number: 1489308
Customer: Rodriguez, Michael
eMarket Payments
Date: 12/19/2025

Description	Amount
4-Hour Ethics Course for Special Districts 2025 Membership status: Non-Member Fee Michael Rodriguez Harbor Bay CDD 4-Hour Ethics Course for Special Districts 2025 https://elearning.iog.fsu.edu/enroll/3196788? price_id=4082495	\$79.00
Total	\$79.00

Payments Received	Amount
FSU eMarket Credit Card MasterCard XXXXXXXXXXXX1471 Authorization # 00362P	\$79.00
Total	\$79.00



7211 US Highway 19 N
Pinellas Park, FL 33781
(727) 327-7755

Date- 01-20-26

Invoice

INVp-9817

www.signarama-pinellas.com

GL Code- 572004833

Completed Date: 1/20/2026

Payment Terms: 50/50

Approved by- JN

Payment Due Date: 1/20/2026

Created Date: 5/14/2025

DESCRIPTION: Mira Bay signage update PART 2

Bill To: Harbor Bay Community Development District, C/O Rizzetta
3434 Colwell Ave Suite 200
Tampa, FL 33614
US

Pickup At: Signarama Pinellas
7211 US Highway 19 N
Pinellas Park, FL 33781
US

Ordered By: Joel Newton
Email: Fieldops@mirabayclub.com
Tax ID: 85-8012574204C-8

Salesperson: Christopher Oliszewski
Email: Chris@signarama-pinellas.com

NO.	Product Summary	QTY	UNIT PRICE	TAXABLE	AMOUNT
1	Main Pool Entrance Sign	1	\$173.44	\$173.44	\$173.44
1.1	Composite Aluminum, 6mm -				
1.2	Vinyl Print Cal Air Release -				
2	Admiral Point Pool Rules	1	\$78.00	\$78.00	\$78.00
2.1	Composite Aluminum, 6mm -				
	Text: 30 persons Dusk to dawn				
3	Main Pool Rules Sign	3	\$243.41	\$730.23	\$730.23
3.1	Composite Aluminum, 6mm -				
3.2	Vinyl Print Cal Air Release -				
4	Kids Pool Rules	1	\$206.00	\$206.00	\$206.00
4.1	Composite Aluminum, 6mm -				
4.2	Vinyl Print Cal Air Release -				
5	Restricted Area Employees Only	1	\$96.96	\$96.96	\$96.96
5.1	Composite Aluminum, 6mm -				
5.2	Vinyl Print Cal Air Release -				
	Text: Contains Chemicals No Smoking				
6	Kid/Wading Pool Sign	1	\$128.70	\$128.70	\$128.70
6.1	Composite Aluminum, 6mm -				
7	Handicap Accessible Entrance Sign	1	\$91.64	\$91.64	\$91.64
7.1	Aluminum, 12"x18", .080, Radius Corners -				
7.2	Vinyl Print Cal Air Release -				
8	Dockers Sign	1	\$87.51	\$87.51	\$87.51

8.1	Composite Aluminum, 6mm -
8.2	Vinyl Print Cal Air Release -

Thanks for choosing us! If you have any questions or comments during this process, please don't hesitate to reach out. We'll work hard to ensure your project is completed on time and on budget.

We've been producing quality signs and graphics to help businesses grow for more than 24 years. Let us help you grow your business with signs, graphics, and wraps! If you have other projects on the horizon, we'd love to provide additional estimates.

Standard payment terms are 50% deposit for orders over \$500, with the balance due upon pickup or installation. Orders under \$500 are paid in full at time of order.

Subtotal:	\$1,592.48
Taxable Amount:	\$1,592.48
Taxes:	\$111.47
Grand Total:	\$1,703.95
Amount Paid:	\$0.00
BALANCE DUE:	\$1,703.95
<i>Credit Card Surcharge:</i>	3.00%
<i>Balance Due with Surcharge:</i>	\$1,755.07

TRANSACTIONS		
Date	Type	Amount
6/30/2025	Check 006624	\$1,794.40
7/21/2025	CustomerCredit	(\$1,794.40)

Serving all of Pinellas since 2001
Signs, Banners, Wraps, Lettering, Printing, & Graphics



PERSSON, COHEN, MOONEY, FERNANDEZ & JACKSON, P.A.
ATTORNEYS AND COUNSELORS AT LAW

INVOICE

Invoice # 6694
Date: 02/03/2026
Due On: 03/03/2026

Harbor Bay Community Development District
rizzettacddinvoices@avidbill.com
3434 Colwell Ave, Suite 100
Tampa, FL 33614

Statement of Account

Outstanding Balance	New Charges	Payments Received	Total Amount Outstanding
(\$0.00	+ \$20,055.00) - (\$0.00) = \$20,055.00

Harbor Bay Community Development District

District Attorney Representation

Type	Timekeeper	Date	Notes	Quantity	Rate	Total
Service	AHC	01/02/2026	Review and reply to multiple e-mails re: public records requests. Review e-mail from Chair re: roadway improvements. Review e-mail from Chair re: Park Square conveyance issues.	1.50	\$350.00	\$525.00
Service	KA	01/05/2026	Draf roofing contract.	0.50	\$350.00	\$175.00
Service	KA	01/05/2026	Reviewing insurance for site work vendor to ensure they meet the contract requirements.	0.40	\$350.00	\$140.00
Service	AHC	01/05/2026	Multiple tele-conv. with District Manager re: pending items. Follow-up re: roof RFP issues and review e-mail re: warranty. Exchange e-mails re: roofing investigation. Tele-conv. with Supervisor Nargi re: pending items. Review public records request issues.	1.75	\$350.00	\$612.50
Service	KA	01/06/2026	Continued review of insurance for the company doing the Villemaire shoulder project.	0.20	\$350.00	\$70.00
Service	KA	01/06/2026	Continued work on roofing contract, emailing eng. on project regarding warranty verbiage and final amounts	1.20	\$350.00	\$420.00

for contract.						
Service	AHC	01/06/2026	Review e-mails re: roofing investigation and tele-conv. with Lynn Hayes. Review and gather Best Price Roofing documents and forward to litigation counsel.	0.75	\$350.00	\$262.50
Service	AHC	01/07/2026	Exchange e-mails re: roof contract and exhibits for warranty. Initial review of agenda for 1/15 CDD meeting. Exchange e-mails with Lynn Hayes re: finalization of vendor contracts. Coordinate follow-up meeting re: Park Square conveyance. Exchange e-mails re: public records request to amenities. Exchange e-mails with Chair re: pending items.	1.50	\$350.00	\$525.00
Service	KA	01/07/2026	Addressing emails regarding roof contract.	0.30	\$350.00	\$105.00
Service	AHC	01/08/2026	Review and reply to e-mails re: dock license and calculation of costs. Exchange e-mails re: Certificate of Insurance for e-mail hosting contract. Exchange e-mails re: seawall concerns raised by resident. Review e-mails re: public records request for Paychex records and other public records issues.	1.00	\$350.00	\$350.00
Service	KA	01/08/2026	Continued review of vendor insurance issues and spoke with DM Lynn re insurance.	0.40	\$350.00	\$140.00
Service	KA	01/08/2026	Continued drafting of Roofing contract.	0.75	\$350.00	\$262.50
Service	KA	01/09/2026	Review Mor Sports file and emails.	1.00	\$350.00	\$350.00
Service	AHC	01/09/2026	Review revised insurance certificate for e-mail hosting agreement. Multiple tele-conv. with Lynn Hayes re: pending items including public records issues.	0.75	\$350.00	\$262.50
Service	AHC	01/11/2026	Review e-mail exchange with Manager and Lockom re: public records request.	0.25	\$350.00	\$87.50
Service	AHC	01/12/2026	Review e-mails re: public records issues and compile response regarding request for e-mails. Exchange e-mails with Chastity re: holiday event and response to public records request related to event.	1.25	\$350.00	\$437.50

Initial review of event SOP.						
Service	KA	01/13/2026	Continue drafting and forward Roof contract to Attorney Cohen for review.	0.60	\$350.00	\$210.00
Service	KA	01/13/2026	Review SOP for vendor's market. Draft email with suggestions and responding to emails.	1.10	\$350.00	\$385.00
Service	AHC	01/13/2026	Continued e-mail exchange re: records requests. Tele-conv. with Mike Gallo re: POS contract issues. Confer with associate counsel and with Chastity Kelly re: SOP for holiday event. Review executed tennis maintenance contract.	0.50	\$350.00	\$175.00
Service	JB	01/13/2026	Reviewed HBCDDD Lagoon Erosion Control Memo, researched applicable case law pertaining to duties of estates pertaining to easements.	2.00	\$175.00	\$350.00
Service	JB	01/14/2026	Met with atty. Cohen prior to zoom meeting and discussed meeting items. Attended meeting with HBCDD. Following the meeting, reviewed the contracts in place re: canals, Signet dr. dedication to county, and security house/gate. Summarized my findings to atty. Cohen.	2.80	\$175.00	\$490.00
Service	AHC	01/14/2026	Review Park Square conveyance issues and prepare for Teams meeting with Engineer, Sang, Chair and District Manager. Attend meeting. Follow-up on action items post meeting. Prepare for and attend Teams meeting with litigation counsel re: Best Price Roofing deposit demands. Continued review of agenda package and prepare for 1/15 CDD meeting. Tele-conv. with District Manager re: items for 1/15 CDD meeting.	5.00	\$350.00	\$1,750.00
Service	JB	01/14/2026	Drafted response to Park Square settlement offer and sent to atty. Cohen for review.	1.50	\$175.00	\$262.50
Service	DPL	01/14/2026	Follow up research on voting conflicts by reviewing ethics opinions, attorney general opinions, statutes, and the sunshine manual.	2.00	\$350.00	\$700.00
Service	KA	01/14/2026	Emails, finishing up roofing contract with latest information on warranty,	2.00	\$350.00	\$700.00

			and sending revised roofing contract to Attorney Cohen for review.			
Service	AHC	01/15/2026	Review research re: voting conflict of interest issues. Exchange e-mails re: Best Price roofing claims. Review revised roof agreement prepared by associate counsel. Further revise agreement and e-mail to engineers and management for review/comment. Tele-conv. with Supervisor Leventry re: pending items for CDD meeting. Continued review and preparation for CDD meeting. Attend meeting.	7.25	\$350.00	\$2,537.50
Service	JB	01/16/2026	Searched County Record for Signet Dr. Dedication.	1.00	\$175.00	\$175.00
Service	JB	01/16/2026	Completed required research and finished draft response to settlement demand. Sent to atty. Cohen for review. Discussed further revisions presented by atty. Cohen.	1.70	\$175.00	\$297.50
Service	AHC	01/16/2026	Follow-up on action items from 1/15 CDD meeting. Exchange e-mails re: Ethics issues. Continued review of Park Square conveyance issues and e-mail Park Square counsel.	2.00	\$350.00	\$700.00
Service	KA	01/16/2026	Reviewing employee handbook.	2.10	\$350.00	\$735.00
Service	AHC	01/19/2026	Review and reply to e-mails re: noise complaint, qualifications of engineer, and dredging issues.	0.25	\$350.00	\$87.50
Service	JB	01/20/2026	Reviewed correspondence from HBCDD via email.	0.10	\$175.00	\$17.50
Service	KA	01/20/2026	Drafting contract for tennis court maintenance.	2.00	\$350.00	\$700.00
Service	KA	01/20/2026	Continued review and commenting on the Employee handbook.	1.25	\$350.00	\$437.50
Service	AHC	01/20/2026	Review and reply to e-mail from Chair re: Park Square. Review CDD meeting summary. Exchange e-mails with Chastity re: public records request. Review e-mail re: engineer services. Confer with associate counsel re: employee manual.	1.25	\$350.00	\$437.50
Service	AHC	01/21/2026	Review comments from associate counsel re: employee manual and forward to Chastity. Exchange e-mails	0.75	\$350.00	\$262.50

			re: public records requests. Exchange e-mails re: Park Square issues.			
Service	KA	01/21/2026	Finished reviewing and commenting on the Employee handbook and sent comments to Attorney Cohen.	2.80	\$350.00	\$980.00
Service	JB	01/22/2026	Received and reviewed videos and photos sent by CDD concerning Park Square conveyance property.	0.20	\$175.00	\$35.00
Service	AHC	01/22/2026	Review Marisol Pointe and other videos sent by Chair re: Park Square conveyance.	0.25	\$350.00	\$87.50
Service	AHC	01/23/2026	Continued review of Park Square issues. Follow-up on action items.	0.50	\$350.00	\$175.00
Service	KA	01/23/2026	Finished drafting J Courts maintenance contract.	1.10	\$350.00	\$385.00
Service	AHC	01/26/2026	Review J Courts maintenance contract prepared by associate counsel. Revise contract and e-mail to management to coordinate execution. Follow-up with litigation counsel re: Best Price Roofing. Exchange e-mails re: finalization of roofing contract. Review e-mails re: investigator.	0.75	\$350.00	\$262.50
Service	AHC	01/27/2026	Tele-conv. with District Manager re: e-blast for tennis court remediation and additional pending items. Review e-mails re: public records request related to meeting audio. Exchange e-mails with Supervisor Leventry re: Park Square and additional pending items.	0.75	\$350.00	\$262.50
Service	AHC	01/28/2026	Exchange e-mails re: boar removal agreement. Review and reply to e-mails re: amenity rules. Review e-mails re: 3rd party investigator. Follow-up on pending items including roof contract.	0.50	\$350.00	\$175.00
Service	AHC	01/29/2026	Review pending items and prepare for call with Supervisor Leventry to discuss Park Square and other CDD issues. Attend call. Follow-up on action items including POS agreement, and review amenity rules re: suspension of resident privileges.	1.75	\$350.00	\$612.50
Service	AHC	01/30/2026	Review and reply to e-mail from Christina Grubbs re: roof contract.	2.50	\$350.00	\$875.00

		<ul style="list-style-type: none"> Research issues related to contract. Continued review of amenity rules. Prepare letter to Tolk re: amenity privileges and mail certified and regular mail with copy to Board and management. Tele-conv. with Chairman re: pending items. 				
Service	KA	01/30/2026	Confer with Attorney Cohen following email from engineer re: roofing contract provisions.	0.20	\$350.00	\$70.00
				Subtotal	\$20,055.00	
				Total	\$20,055.00	

Detailed Statement of Account

Current Invoice

Invoice Number	Due On	Amount Due	Payments Received	Balance Due	
6694	03/03/2026	\$20,055.00	\$0.00	\$20,055.00	
				Outstanding Balance	\$20,055.00
				Total Amount Outstanding	\$20,055.00

Please make all amounts payable to: Persson, Cohen, Mooney, Fernandez & Jackson, P.A. and remit to 6853 ENERGY COURT, LAKEWOOD RANCH, FL 34240.

For any inquiries, please contact us at 941-306-4730. Payment is due 30 days from receipt of this invoice. Thank you.

**PHENOMENAL EXERCISE EQUIPMENT REPAIR
SERVICE INC**

5332 Caesar Way South Suite A
St Petersburg, FL 33712-4277
US
7278668188
phenom@tampabay.rr.com

Invoice

BILL TO

Harbor Bay Community Development
District C/o Rizzetta & Company
3434 Colwell Avenue, Suite 200
Tampa, FL 33614

INVOICE #	DATE	TOTAL DUE	DUE DATE	TERMS	ENCLOSED
246908	01/27/2026	\$145.00	02/26/2026	Net 30	

SERVICE REP

Nick/Zach

DESCRIPTION	QTY	RATE	AMOUNT
Maintenance Fee - Cleaned, Lubed & Adjusted equipment.	1	145.00	145.00T

Please submit payment to the address above.

Thank you for your business!

SUBTOTAL	145.00
TAX	0.00
TOTAL	145.00
BALANCE DUE	\$145.00

Pay invoice

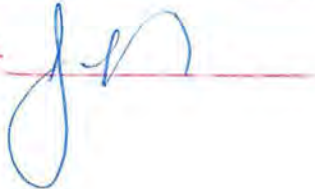
Date- 02-03-26
GL Code- 572004914
Approved by- 

**PHENOMENAL EXERCISE EQUIPMENT REPAIR
SERVICE INC**

5332 Caesar Way South Suite A
St Petersburg, FL 33712-4277
US
7278668188
phenom@tampabay.rr.com

Invoice

BILL TO

Harbor Bay Community Development
District C/o Rizzetta & Company
3434 Colwell Avenue, Suite 200
Tampa, FL 33614

INVOICE #	DATE	TOTAL DUE	DUE DATE	TERMS	ENCLOSED
246937	02/02/2026	\$150.00	03/04/2026	Net 30	

SERVICE REP

Rich

DESCRIPTION	QTY	RATE	AMOUNT
Tricep handle Rope	1	45.00	45.00T
Handles	2	15.00	30.00T
Installation	1	75.00	75.00T

Please submit payment to the address above.

Thank you for your business!

SUBTOTAL	150.00
TAX	0.00
TOTAL	150.00
BALANCE DUE	\$150.00

Pay invoice

Date- 02-03-26

GL Code- 572004914

Approved by- [Signature]

Signature:

**PHENOMENAL EXERCISE EQUIPMENT REPAIR
SERVICE INC**

5332 Caesar Way South Suite A
St Petersburg, FL 33712-4277
US
7278668188
phenom@tampabay.rr.com

Invoice

Date- 02-20-26

GL Code- 572004914

Approved by- _____

BILL TO

Harbor Bay Community Development
District C/o Rizzetta & Company
3434 Colwell Avenue, Suite 200
Tampa, FL 33614

INVOICE #	DATE	TOTAL DUE	DUE DATE	TERMS	ENCLOSED
246976	02/10/2026	\$145.00	03/12/2026	Net 30	

SERVICE REP

Nick/Zach

DESCRIPTION	QTY	RATE	AMOUNT
Maintenance Fee - Cleaned, Lubed & Adjusted equipment.	1	145.00	145.00T

Please submit payment to the address above.

Thank you for your business!

SUBTOTAL	145.00
TAX	0.00
TOTAL	145.00
BALANCE DUE	\$145.00

Pay invoice

Signature:



5210 W Linebaugh Ave
Tampa FL 33624-503434

Customer Service (813) 265-0292
RepublicServices.com/Support

Important Information

It's easy to go paperless! Sign up for Paperless Billing at RepublicServices.com and enjoy the convenience of managing your account anytime, anywhere, on any device.

Account Number 3-0696-0020461
Invoice Number 0696-001325545
Invoice Date January 17, 2026
Previous Balance \$1,293.96
Payments/Adjustments -\$1,293.96
Current Invoice Charges \$1,448.20

RECEIVED
JAN 23 2026

BY:

Autopayment \$1,448.20	Payment Due Date February 06, 2026
---	---

PAYMENTS/ADJUSTMENTS

Description	Reference	Amount
Payment - Thank You 01/06	5555555	-\$1,293.96

CURRENT INVOICE CHARGES

Description	Reference	Quantity	Unit Price	Amount
Mira Bay Clubhouse 107 Manns Harbor Dr CSA A912018655				
Apollo Beach, FL Contract: 9696002 (C1)				
1 Waste Container 6 Cu Yd, 2 Lifts Per Week				
Disposal:SOUTH CO - CLASS 1				
Waste/Recycling Overage 01/09		1.0000	\$75.00	\$75.00
Pickup Service 02/01-02/28			\$910.56	\$910.56

Admiral Pointe Clubhouse 5248 Admiral Pointe Dr CSA A912018554
Apollo Beach, FL

1 Waste Container 4 Cu Yd, 1 Lift Per Week

Disposal:SOUTH CO - CLASS 1

Waste/Recycling Overage 01/07

Pickup Service 02/01-02/28

1.0000 \$79.24 \$79.24
\$383.40 \$383.40

CURRENT INVOICE CHARGES, AutoPayment due on February 06, 2026

\$1,448.20

Simple account access at your fingertips.

Download the Republic Services app or visit RepublicServices.com today.



5210 W Linebaugh Ave
Tampa FL 33624-503434

Do not Pay
* Thank You For Your Automatic Payment *

Autopayment \$1,448.20
Payment Due Date February 06, 2026
Account Number 3-0696-0020461
Invoice Number 0696-001325545

Address Service Requested

For Billing Address Changes,
Check Box and Complete Reverse.

Make Checks Payable To:



00001126
N202
HARBOR BAY CCD
MARK ISLEY
3434 COLWELL AVE
STE 200
TAMPA FL 33614-8390



REPUBLIC SERVICES #696
PO BOX 71068
CHARLOTTE NC 28272-1068

30696002046100000013255450001448200001448200



UNDERSTANDING YOUR BILL

Visit RepublicServices.com/MyBill

UNDERSTANDING OUR RATES, CHARGES, AND FEES

Visit Republicservices.com/customer-support/fee-disclosures

Responsible Party

All waste services are managed, performed, and billed for by individual operating subsidiaries of Republic Services, Inc. Republic Services, Inc. itself does not perform any waste services, nor does it contract for such services. The operating entity providing your waste service is identified on your invoice. Accordingly, all obligations to you, including providing quality service and billing you for service, rests with the operating entity identified on your invoice.

Residential Customers

If you are a residential customer receiving service without a signed customer service agreement, your service is subject to and governed by the Service Terms for Residential Customers located at Republicservices.com/customer-support/residential-service-terms which include a **CLASS ACTION WAIVER** and **ARBITRATION CLAUSE**, and our right to charge you a container removal fee upon termination of service, among other terms. These terms are subject to change so please review them upon receipt of your invoice. If you do not have access to a computer, you may request that a copy be mailed to you by calling Customer Service at the number on the front of this invoice. Please note that some or all of the Service Terms for Residential Customers may not apply if your services are subject to terms mandated by a governmental entity in your locality.

Check Processing

When you provide a check as payment, you authorize us to use information from your check to make a one-time electronic fund transfer from your account. When we make an electronic transfer, funds may be withdrawn from your account the same day we receive your payment or check and you will not receive your check back from your financial institution.

Cancellation & Payment Policy

Unless prohibited by applicable law, regulation, or franchise or other agreement: (1) we reserve the right to require that payment for services be made only by check, credit card or money order; and (2) if service is canceled during a billing cycle, you will remain responsible for all charges, fees and taxes through the end of the billing cycle. You will not be entitled to proration of billing or a refund for the period between the notice of termination and the end of the current billing cycle.

Understanding Our Rates, Charges and Fees

If you are receiving service without a signed customer service agreement, please visit RepublicServices.com/Fees to review the financial terms and conditions relating to your service. If you are receiving service pursuant to a written contract, but have questions relating to any charges or fees, RepublicServices.com/Fees provides a detailed description of our most common charges and fees. If you do not have access to a computer, you may request that a copy be mailed to you by calling Customer Service at the number on the front of this invoice.

Please fill out the form below if your billing address has changed and return this portion of your statement to us using the envelope enclosed. Thank you!

BILLING ADDRESS CHANGE

Address		
City	State	Zip Code
Phone	Alternate Phone	

CRPBLIC1 8422 6205 127 07 20260118 PG 1 OF 1 0-1 4190396 00001128 57890721.1

RM-3159

Rizzetta & Company, Inc.
 3434 Colwell Avenue
 Suite 200
 Tampa FL 33614

Invoice

Date	Invoice #
2/2/2026	INV0000106713

Bill To:

HARBOR BAY CDD 3434 Colwell Avenue, Suite 200 Tampa FL 33614
--

Services for the month of	Terms	Client Number
February	Upon Receipt	00815

Description	Qty	Rate	Amount
Accounting Services	1.00	\$4,316.67	\$4,316.67
Annual Dissemination Services	1.00	\$416.67	\$416.67
Financial & Revenue Collections Services	1.00	\$416.67	\$416.67
Management Services	1.00	\$10,329.17	\$10,329.17
Website Compliance & Management	1.00	\$234.42	\$234.42
Subtotal			\$15,713.60
Total			\$15,713.60

INVOICE

S & W REFRIGERATION, LLC
11516 Perpetual Dr
Odessa, FL 33556 3464

accounting@theicedoctors.com
+1 (813) 948 6241



Bill to

Roxanne Benton
Mira Bay DBA Harbor Bay CDD
250 International Parkway Suite 280
Lake Mary, FL 32746

Invoice details

Invoice no.: 84393
Invoice date: 06/25/2025
Due date: 07/05/2025

#	Product or service	Description	Qty	Rate	Amount
1.	Service call	Service call	1	\$125.00	\$125.00
2.	Manitowoc Replacement Filter K00493	Manitowoc Replacement Filter Fits AR 1000 P filter system Item: K00493 MFG: K00493	1	\$186.88	\$186.88
3.	Labor	Labor	1.5	\$125.00	\$187.50

Subtotal \$499.38

Sales tax \$37.45

Total \$536.83

Note to customer

Water pressure was low coming into machine. Bypassed filter and water pressure was good. Don't have the filter in my truck needed. Will be back in the area tomorrow so will return to replace filter. Returned with filter. Replaced and watched machine fill with water like normal.

Overdue

07/05/2025

INVOICE

S & W REFRIGERATION, LLC
11516 Perpetual Dr
Odessa, FL 33556 3464

accounting@theicedoctors.com
+1 (813) 948 6241



Bill to

Roxanne Benton
Mira Bay DBA Harbor Bay CDD
250 International Parkway Suite 280
Lake Mary, FL 32746

Invoice details

Invoice no.: 86499
Invoice date: 12/30/2024
Due date: 12/30/2024

#	Product or service	Description	Qty	Rate	Amount
1.		Job# 111536			
2.		Job Description: Install KDT 500A and K570 bin. Price is \$5,443			
3.	Sales/Installation	Arctic Pure Water Filter System, with K00493 Cartridge	1	\$0.00	\$0.00
4.	Sales/Installation	Installation	1	\$0.00	\$0.00
5.	Sales/Installation	KDT0500A-161/1121143229 K570/1121107662	1	\$5,443.00	\$5,443.00
6.	Late Fee	Late Fee	1	\$544.30	\$544.30

Total **\$5,987.30**

Ways to pay



Overdue 12/30/2024

Note to customer

Completion Notes: Moved old machine to new location. Installed new machine and bin. Moved old water filter. Installed new water filter. Waited for machine to drop ice. New machine running well. Old machine wasn't turned on as customer will be installing drain for old machine.

[View and pay](#)

SCHINDLER ELEVATOR CORPORATION
1150 Assembly Drive, Suite 360
TAMPA FL 33607-4873
Tel: 813 888 5335 Fax: 813 888 7785

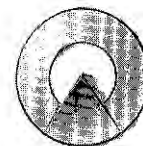

Schindler

FEB - 2 2026

Document: Maintenance Invoice

Invoice No : 4607373273

Date : 02/01/2026

HARBOR BAY COMMUNITY DEVELOPMENT
DISTRICT
C/O RIZZETTA & COMPANY
3434 COLWELL AVENUE, STE.,200
TAMPA FL 33614

Billing ID: 3102282
Federal Tax ID: 34 127 0056
DUNS Number: 09 480 9993
Sales Contact: Chanteal M.Murphy
Field Contact: Alejandro Casas
PO Number:

Contract No:	USD	Tax	USD
4100035904	excl.Tax		incl.Tax

No. of Equipment:	2		
Service type:	Preventive Maintenance		
	Schindler Basic Partial		
Address:	MIRABAY HARBOR BAY CLUBHOUSE MANNS HARBOR DR 107 33572 APOLLO BEACH		
Maintenance services:	From 02/01/2026 to 02/28/2026		
Total	263.01		263.01

Total to Pay 263.01

Payment terms: Payable within 30 days



Please return this portion with your payment

REMITTANCE

Payer :
HARBOR BAY COMMUNITY DEVELOPMENT
DISTRICT
C/O RIZZETTA & COMPANY
3434 COLWELL AVENUE, STE.,200
TAMPA FL 33614

Invoice No : 4607373273
Date : 02/01/2026
Billing ID : 3102282
Service Contract : 4100035904

INVOICE AMOUNT: 263.01 USD

Remit to :
Schindler Elevator Corporation Use this address for payments only.
P.O.Box 93050 Direct calls and correspondence to our Local Office above.
Chicago, IL 60673-3050 Please check applicable payment enclosed

* Invoices not paid within net terms are subject to a service charge of 1.5% per month, or the maximum permitted by law.

Seller represents that with respect to the production of the articles and/or the performance of the services covered by this invoice, it has fully complied with the FairLabor Standards Act of 1938, as amended.

January 27, 2026
Invoice Number: 2389447012726
Account Number: 8337 12 028 2389447
Security Code:
Service At: 107 MANNNS HARBOR DR
APOLLO BEACH FL 33572-3340

Auto Pay Notice

RECEIVED
FEB - 5 2026

NEWS AND INFORMATION

Contact Us

Visit us at SpectrumBusiness.net
Or, call us at **855-252-0675**

Summary

*Service from 01/27/26 through 02/26/26
details on following pages*

Previous Balance	318.00
Payments Received -Thank You!	-318.00
Remaining Balance	\$0.00
Spectrum Business™ TV	290.00
Other Charges	28.00
Current Charges	\$318.00
YOUR AUTO PAY WILL BE PROCESSED 02/14/26	
Total Due by Auto Pay	\$318.00

IMPORTANT BILLING UPDATE

At Spectrum Business, we value your experience and are dedicated to constantly enhancing our services to ensure you receive the very best. We understand that rising costs can be frustrating, and we want to be transparent that these increases have affected our prices.

Effective with your next statement, the following pricing will change.

- Broadcast TV Surcharge will increase by \$3 per month
- Spectrum Business Receivers will increase by \$1 each per month
- There will be a \$5 per month charge to receive paper statements. To sign up for paperless billing and avoid this charge visit SpectrumBusiness.net/Paperless today

To learn about how these changes benefit your services now and, in the future, visit Spectrum.net/Enhancements.

You're eligible for the nation's most reliable Internet. Call 1-855-726-8541.

Connect your business, your way. Call 1-855-751-9942 today.

Thank you for choosing Spectrum Business.
We appreciate your prompt payment and value you as a customer.

Auto Pay - Thank you for signing up for Auto Pay. Please note your payment may be drafted and posted to your Spectrum Business account the day after your transaction is scheduled to be processed by your bank.



4145 S. FALKENBURG RD RIVERVIEW FL 33578-8652
8633 2390 DY RP 27 01282028 NNNNNNNN 01 001017 0004

MIRA BAY CLUB
GMS TAMPA LLC
3434 COLWELL AVE STE 200
TAMPA FL 33614-8390

January 27, 2026

MIRA BAY CLUB

Invoice Number: 2389447012726
Account Number: 8337 12 028 2389447
Service At: 107 MANNNS HARBOR DR
APOLLO BEACH FL 33572-3340

Total Due by Auto Pay \$318.00



CHARTER COMMUNICATIONS
PO BOX 7186
PASADENA CA 91109-7186



833712028238944700318006



Invoice Number: MIRA BAY CLUB
 Account Number: 2389447012726
 Security Code: 8337 12 028 2389447

Contact Us
 Visit us at SpectrumBusiness.net
 Or, call us at **855-252-0675**

8833 2390 DY RP 27 01282026 NNNNNNNN 01 001017 0004

Charge Details

Previous Balance		318.00
EFT Payment	01/14	-318.00
Remaining Balance		\$0.00

Payments received after 01/27/26 will appear on your next bill.
 Service from 01/27/26 through 02/26/26

Spectrum Business™ TV

Spectrum Business Premier		80.00
Spectrum Receivers	15 Receivers at 14.00 each	210.00
		\$290.00
Spectrum Business™ TV Total		\$290.00

Other Charges

Broadcast TV Surcharge		28.00
Payment Processing		5.00
Auto Pay Discount		-5.00
Other Charges Total		\$28.00
Current Charges		\$318.00
Total Due by Auto Pay		\$318.00

Billing Information

Tax and Fees - This statement reflects the current taxes and fees for your area (including sales, excise, user taxes, etc.). These taxes and fees may change without notice. Visit spectrum.net/taxesandfees for more information.

Spectrum Terms and Conditions of Service - In accordance with the Spectrum Business Services Agreement, Spectrum services are billed on a monthly basis. Spectrum does not provide credits for monthly subscription services that are cancelled prior to the end of the current billing month.

Terms & Conditions - Spectrum's detailed standard terms and conditions for service are located at spectrum.com/policies.

Notice - Nonpayment of any portion of your cable television, high-speed data, and/or Digital Phone service could result in disconnection of any of your Spectrum provided services.

Insufficient Funds Payment Policy - Charter may charge an insufficient funds processing fee for all returned checks and bankcard charge-backs. If your check, bankcard (debit or credit) charge, or other instrument or electronic transfer transaction used to pay us is dishonored, refused or returned for any reason, we may electronically debit your account for the payment, plus an insufficient funds processing fee as set forth in your terms of service or on your Video Services rate card (up to the amount allowable by law and any applicable sales tax). Your bank account may be debited as early as the same day payment is dishonored, refused or returned. If your bank account is not debited, the returned check amount (plus fee) must be replaced by cash, cashier's check or money order.

Billing Practices - Spectrum Business mails monthly, itemized invoices for all monthly services in advance. A full payment is required on or before the due date indicated on this invoice. Payments made after the indicated due date may result in a late payment processing charge. Failure to pay could result in the disconnection of all your Spectrum Business service(s). Disconnection of Business Voice service may also result in the loss of your phone number.

Changing Business Locations - Please contact Spectrum Business before moving your Business Voice modem to a new address. To establish service at your new location or return equipment, please contact Spectrum Business at least twenty-one (21) business days prior to your move.

Past Due Fee / Late Fee Reminder - A late fee will be assessed for past due charges for service.

Complaint Procedures: If you disagree with your charges, you need to register a complaint no later than 60 days after the due date on your bill statement.

Continued on the next page...

Local Spectrum Store: 12970 S US Hwy 301, Suite 105, Riverview FL 33579 Store Hours: Mon thru Sat - 10:00am to 8:00pm; Sun - 12:00pm to 7:00pm

Local Spectrum Store: 872 Brandon Town Center Mall, Brandon FL 33511 Store Hours: Mon thru Sat - 10:00am to 8:00pm and Sun - 12:00pm to 5:00pm



For questions or concerns, please call 1-866-519-1263.



January 27, 2026



Invoice Number: MIRA BAY CLUB
2389447012726
Account Number: 8337 12 028 2389447
Security Code:

Contact Us
Visit us at SpectrumBusiness.net
Or, call us at **855-252-0675**

8633 2380 DY RP 27 01282026 NNNNNNNN 01 001017 0004

Video Closed Captioning Inquiries - Spectrum provided set-top boxes for video consumption support the ability for the user to enable or disable Closed Captions for customers with hearing impairment.

For immediate closed captioning concerns, call **855-70-SPECTRUM** or email closedcaptioningsupport@charter.com.

To report a complaint on an ongoing closed captioning issue, please send your concerns via US Mail to W. Wesselman, Sr. Director, 2 Digital Place, Simpsonville, SC 29681, send a fax to **1-704-697-4935**, call **1-877-276-7432** or email closedcaptioningissues@charter.com.



Invoice Number:
Account Number:
Security Code:

MIRA BAY CLUB
2389447012726
8337 12 028 2389447

Contact Us
Visit us at SpectrumBusiness.net
Or, call us at **855-252-0675**

8633 2390 DY RP 27 01282026 NNNNNNNN 01 001017 0004



Connect your business, your way

Choose our all-in-one communication hub or our traditional Voice product



Business Connect with RingCentral

\$20 /mo
per user for two years

2-user minimum. Spectrum Business Internet required.

- ✓ Cloud-based solution with calling, texting, meetings and file sharing on one simple platform
- ✓ Manage your business from any location using any device—mobile phone, tablet or laptop
- ✓ Features like Call Routing and Auto-Attendant give your business a polished image and let clients quickly reach the right person

Business Voice

\$20 /mo
per line

for one year with Business Internet.

- ✓ Unlimited local and long-distance calling
- ✓ 35+ advanced calling features including Smart Call Screening, Call Hold, 3-way Calling, Call Waiting, Voicemail and Forwarding

Switch now, risk-free. Call 1-855-752-1855.

Offer good through 03/01/26

Limited-time offer; subject to change. Qualified Spectrum Business customers only. Must not have subscribed to applicable services w/ in the last 30 days & have no outstanding obligation to Charter. Standard rates apply after promo period or if qualifying services not maintained. A monthly \$5 Payment Processing Charge will be applied to customer accounts not enrolled in Auto Pay. **VOICE:** Offer requires bundled purchase with Business Internet. Includes unlimited local and long-distance calling to U.S., Puerto Rico and Canada, plus 2,000 long-distance calling minutes to Mexico. **CONNECT:** Offer requires purchase of Business Connect (min of 2 users) w/ Business Internet. Not compatible with all desk phones. Phone equipment is not included with service. Services subject to all applicable service terms & conditions, which are subject to change. Services & promo. offers not avail. in all areas. Pricing subject to change. Installation & other equipment charges, taxes & fees may apply. Restrictions apply. Call for details. ©2025 Charter Communications, all rights reserved.



HARBOR BAY COMMUNITY DEVELOPMENT
5256 ADMIRAL POINTE DR
APOLLO BEACH, FL 33572-3429

Statement Date: January 29, 2026

Amount Due:	\$88.07
Due Date: February 19, 2026	
Account #: 211009424139	

DO NOT PAY. Your account will be drafted on February 19, 2026

Account Summary

Current Service Period: December 23, 2025 - January 23, 2026	
Previous Amount Due	\$85.77
Payment(s) Received Since Last Statement	-\$83.66
Miscellaneous Credits	-\$2.11
Current Month's Charges	\$88.07
Amount Due by February 19, 2026	\$88.07

Amount not paid by due date may be assessed a late payment charge and an additional deposit.

Monthly Usage (kWh)

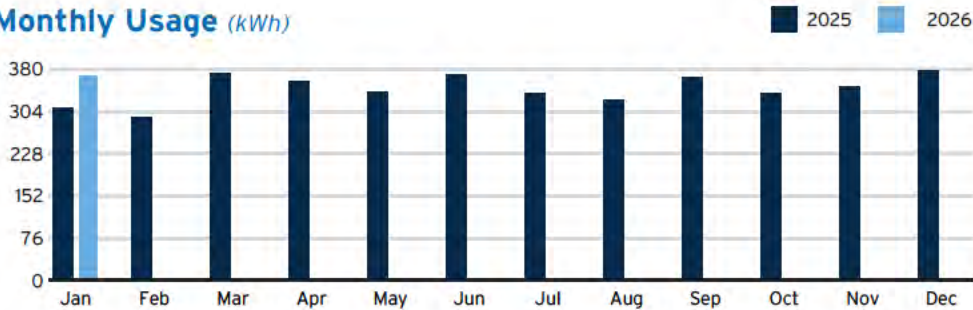

Learn about your newly redesigned bill and get deeper insights about your usage by visiting TECOaccount.com

Your Energy Insight

Your average daily kWh used was **22.22% higher** than the same period last year.

Your average daily kWh used was **8.33% lower** than it was in your previous period.

Scan here to view your account online.

2025
2026

New Year, New Ways to Simplify

Get quick text, email or automated call alerts for outages, bills, payments, appointments and more. Just log in and choose the notifications you want.

Get started today at TECOaccount.com.



To ensure prompt credit, please return stub portion of this bill with your payment.

Pay your bill online at TampaElectric.com
See reverse side of your paystub for more ways to pay.

Go Paperless, Go Green! Visit TampaElectric.com/Paperless to enroll now.

Account #: 211009424139
Due Date: February 19, 2026

Amount Due:	\$88.07
Payment Amount: \$ _____	

618051267171

Your account will be drafted on February 19, 2026

HARBOR BAY COMMUNITY DEVELOPMENT
250 INTERNATIONAL PKWY, STE 208
LAKE MARY, FL 32746-5062

Mail payment to:
TECO
P.O. BOX 31318
TAMPA, FL 33631-3318

Make check payable to: TECO
Please write your account number on the memo line of your check.



Service For:
5256 ADMIRAL POINTE DR
APOLLO BEACH, FL 33572-3429

Account #: 211009424139
Statement Date: January 29, 2026
Charges Due: February 19, 2026

Meter Read

Service Period: Dec 23, 2025 - Jan 23, 2026

Rate Schedule: General Service - Non Demand

Meter Number	Read Date	Current Reading	Previous Reading	=	Total Used	Multiplier	Billing Period
1000430767	01/23/2026	27,762	27,395		367 kWh	1	32 Days

Charge Details

Electric Charges		
Daily Basic Service Charge	32 days @ \$0.66000	\$21.12
Energy Charge	367 kWh @ \$0.09202/kWh	\$33.77
Fuel Charge	367 kWh @ \$0.03516/kWh	\$12.90
Storm Protection Charge	367 kWh @ \$0.00568/kWh	\$2.08
Clean Energy Transition Mechanism	367 kWh @ \$0.00418/kWh	\$1.53
Storm Surcharge	367 kWh @ \$0.02121/kWh	\$7.78
Florida Gross Receipt Tax		\$2.03
Electric Service Cost		\$81.21
State Tax		\$6.86
Total Electric Cost, Local Fees and Taxes		\$88.07

Avg kWh Used Per Day

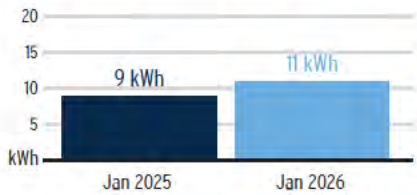

Important Messages

Annual Deposit Interest Credit. This billing statement reflects your annual credit of deposit interest. Thank you for being a valued customer. We appreciate the opportunity to serve you.

Total Current Month's Charges \$88.07

Miscellaneous Credits	
Interest for Cash Security Deposit - Electric	-\$2.11
Total Current Month's Credits	-\$2.11

For more information about your bill and understanding your charges, please visit TampaElectric.com

Ways To Pay Your Bill

- Bank Draft**
Visit TECOaccount.com for free recurring or one time payments via checking or savings account.
- In-Person**
Find list of Payment Agents at TampaElectric.com
- Mail A Check**
Payments:
TECO
P.O. Box 31318
Tampa, FL 33631-3318
Mail your payment in the enclosed envelope.
- Credit or Debit Card**
Pay by credit Card using KUBRA EZ-Pay at TECOaccount.com. Convenience fee will be charged.
- Phone**
Toll Free: **866-689-6469**
- All Other Correspondences:**
Tampa Electric
P.O. Box 111
Tampa, FL 33601-0111

Contact Us

- Online:**
TampaElectric.com
- Phone:**
Commercial Customer Care: 866-832-6249
Residential Customer Care: 813-223-0800 (Hillsborough)
863-299-0800 (Polk County)
888-223-0800 (All Other Counties)
- Hearing Impaired/TTY: 7-1-1
- Power Outage: 877-588-1010
- Energy-Saving Programs: 813-275-3909

Please Note: If you choose to pay your bill at a location not listed on our website or provided by Tampa Electric, you are paying someone who is not authorized to act as a payment agent at Tampa Electric. You bear the risk that this unauthorized party will relay the payment to Tampa Electric and do so in a timely fashion. Tampa Electric is not responsible for payments made to unauthorized agents, including their failure to deliver or timely deliver the payment to us. Such failures may result in late payment charges to your account or service disconnection.



HARBOR BAY COMMUNITY DEVELOPMENT
5248 ADMIRAL POINTE DR
APOLLO BEACH, FL 33572-3429

Statement Date: January 29, 2026

Amount Due: \$1,129.12

Due Date: February 19, 2026

Account #: 211009424568

DO NOT PAY. Your account will be drafted on February 19, 2026

Your Energy Insight

Your average daily kWh used was **32.15% lower** than the same period last year.

Your peak billing demand was **25.81% lower** than the same period last year.

Account Summary

Current Service Period: December 23, 2025 - January 23, 2026

Previous Amount Due	\$953.93
Payment(s) Received Since Last Statement	-\$935.88
Miscellaneous Credits	-\$18.05
Current Month's Charges	\$1,129.12

Amount Due by February 19, 2026 **\$1,129.12**

Amount not paid by due date may be assessed a late payment charge and an additional deposit.



Scan here to view your account online.

Monthly Usage (kWh)

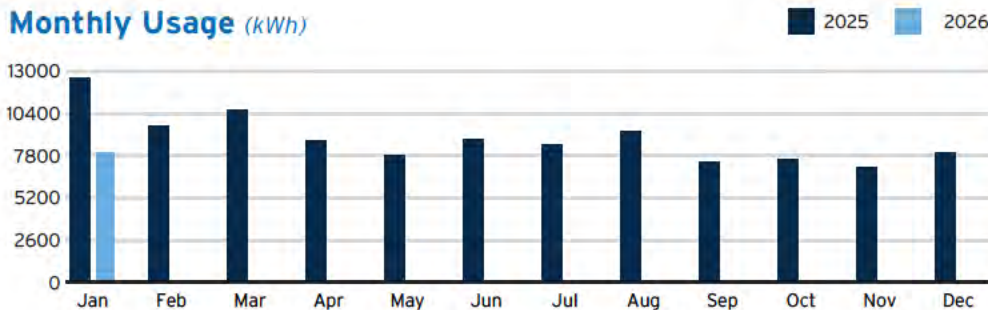

Learn about your newly redesigned bill and get deeper insights about your usage by visiting TECOaccount.com



Get quick text, email or automated call alerts for outages, bills, payments, appointments and more. Just log in and choose the notifications you want.

Get started today at TECOaccount.com.



To ensure prompt credit, please return stub portion of this bill with your payment.

Account #: 211009424568

Due Date: February 19, 2026

Pay your bill online at TampaElectric.com

See reverse side of your paystub for more ways to pay.

Go Paperless, Go Green! Visit TampaElectric.com/Paperless to enroll now.

Amount Due: \$1,129.12

Payment Amount: \$ _____

618051267172

Your account will be drafted on February 19, 2026

HARBOR BAY COMMUNITY DEVELOPMENT
250 INTERNATIONAL PKWY, STE 208
LAKE MARY, FL 32746-5062

Mail payment to:
TECO
P.O. BOX 31318
TAMPA, FL 33631-3318

Make check payable to: TECO
Please write your account number on the memo line of your check.



Service For:
5248 ADMIRAL POINTE DR
APOLLO BEACH, FL 33572-3429

Account #: 211009424568
Statement Date: January 29, 2026
Charges Due: February 19, 2026

Meter Read

Meter Location: Pool

Service Period: Dec 23, 2025 - Jan 23, 2026

Rate Schedule: General Service Demand - Standard

Meter Number	Read Date	Current Reading	Previous Reading	= Total Used	Multiplier	Billing Period
1000862129	01/23/2026	47,787	39,820	7,967 kWh	1	32 Days
1000862129	01/23/2026	22.97	0	22.97 kW	1	32 Days

Charge Details

⚡ Electric Charges		
Daily Basic Service Charge	32 days @ \$1.12000	\$35.84
Billing Demand Charge	23 kW @ \$19.06000/kW	\$438.38
Energy Charge	7,967 kWh @ \$0.00815/kWh	\$64.93
Fuel Charge	7,967 kWh @ \$0.03516/kWh	\$280.12
Capacity Charge	23 kW @ \$0.72000/kW	\$16.56
Storm Protection Charge	23 kW @ \$2.02000/kW	\$46.46
Energy Conservation Charge	23 kW @ \$0.79000/kW	\$18.17
Environmental Cost Recovery	7,967 kWh @ \$0.00072/kWh	\$5.74
Clean Energy Transition Mechanism	23 kW @ \$1.15000/kW	\$26.45
Storm Surcharge	7,967 kWh @ \$0.01035/kWh	\$82.46
Florida Gross Receipt Tax		\$26.03
Electric Service Cost		\$1,041.14
State Tax		\$87.98
Total Electric Cost, Local Fees and Taxes		\$1,129.12

Avg kWh Used Per Day

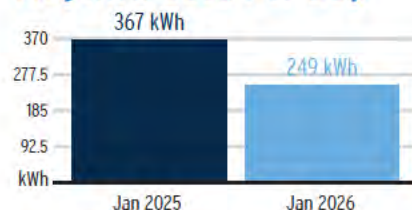

Billing Demand (kW)

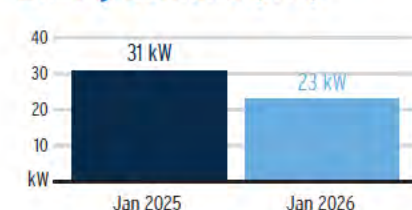

Total Current Month's Charges \$1,129.12

Billing information continues on next page →

For more information about your bill and understanding your charges, please visit TampaElectric.com

Ways To Pay Your Bill

- Bank Draft**
Visit TECOaccount.com for free recurring or one time payments via checking or savings account.
- In-Person**
Find list of Payment Agents at TampaElectric.com
- Mail A Check**
Payments:
TECO
P.O. Box 31318
Tampa, FL 33631-3318
Mail your payment in the enclosed envelope.
- Credit or Debit Card**
Pay by credit Card using KUBRA EZ-Pay at TECOaccount.com. Convenience fee will be charged.
- Phone**
Toll Free: **866-689-6469**
- All Other Correspondences:**
Tampa Electric
P.O. Box 111
Tampa, FL 33601-0111

Contact Us

- Online:**
TampaElectric.com
- Phone:**
Commercial Customer Care: 866-832-6249
Residential Customer Care: 813-223-0800 (Hillsborough)
863-299-0800 (Polk County)
888-223-0800 (All Other Counties)
- Hearing Impaired/TTY: 7-1-1
Power Outage: 877-588-1010
Energy-Saving Programs: 813-275-3909

Please Note: If you choose to pay your bill at a location not listed on our website or provided by Tampa Electric, you are paying someone who is not authorized to act as a payment agent at Tampa Electric. You bear the risk that this unauthorized party will relay the payment to Tampa Electric and do so in a timely fashion. Tampa Electric is not responsible for payments made to unauthorized agents, including their failure to deliver or timely deliver the payment to us. Such failures may result in late payment charges to your account or service disconnection.



Service For:
5248 ADMIRAL POINTE DR
APOLLO BEACH, FL 33572-3429

Account #: 211009424568
Statement Date: January 29, 2026
Charges Due: February 19, 2026

Charge Details *Continued...*

Miscellaneous Credits	
Interest for Cash Security Deposit - Electric	-\$18.05
Total Current Month's Credits	-\$18.05

Load Factor



Decreasing the proportion of your electricity utilized at peak will improve your load factor.

Important Messages

Annual Deposit Interest Credit. This billing statement reflects your annual credit of deposit interest. Thank you for being a valued customer. We appreciate the opportunity to serve you.



HARBOR BAY COMMUNITY DEVELOPMENT
760 WINTERSIDE DR
APOLLO BEACH, FL 33572-3407

Statement Date: January 29, 2026

Amount Due:	\$54.82
Due Date: February 19, 2026	
Account #: 211009425011	

DO NOT PAY. Your account will be drafted on February 19, 2026

Account Summary

Current Service Period: December 23, 2025 - January 23, 2026	
Previous Amount Due	\$52.23
Payment(s) Received Since Last Statement	-\$51.03
Miscellaneous Credits	-\$1.20
Current Month's Charges	\$54.82
Amount Due by February 19, 2026	\$54.82

Amount not paid by due date may be assessed a late payment charge and an additional deposit.

Your Energy Insight

- Your average daily kWh used was **20% higher** than the same period last year.
- Your average daily kWh used was **0% higher** than it was in your previous period.

Scan here to view your account online.

2026
New Year, New Ways to Simplify

Get quick text, email or automated call alerts for outages, bills, payments, appointments and more. Just log in and choose the notifications you want.

Get started today at TECOaccount.com.

Monthly Usage (kWh)

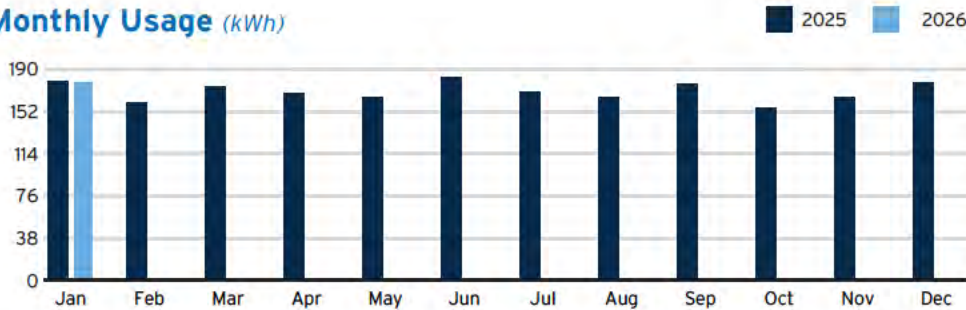

Learn about your newly redesigned bill and get deeper insights about your usage by visiting TECOaccount.com

To ensure prompt credit, please return stub portion of this bill with your payment.



Pay your bill online at TampaElectric.com
See reverse side of your paystub for more ways to pay.

Go Paperless, Go Green! Visit TampaElectric.com/Paperless to enroll now.

Account #: 211009425011
Due Date: February 19, 2026

Amount Due:	\$54.82
Payment Amount:	\$ _____

618051267173

Your account will be drafted on February 19, 2026

HARBOR BAY COMMUNITY DEVELOPMENT
250 INTERNATIONAL PKWY, STE 208
LAKE MARY, FL 32746-5062

Mail payment to:
TECO
P.O. BOX 31318
TAMPA, FL 33631-3318

Make check payable to: TECO
Please write your account number on the memo line of your check.



Service For:
760 WINTERSIDE DR
APOLLO BEACH, FL 33572-3407

Account #: 211009425011
Statement Date: January 29, 2026
Charges Due: February 19, 2026

Meter Read

Meter Location: Gate

Service Period: Dec 23, 2025 - Jan 23, 2026

Rate Schedule: General Service - Non Demand

Meter Number	Read Date	Current Reading	Previous Reading	Total Used	Multiplier	Billing Period
1000444679	01/23/2026	10,527	10,349	178 kWh	1	32 Days

Charge Details

Electric Charges		
Daily Basic Service Charge	32 days @ \$0.66000	\$21.12
Energy Charge	178 kWh @ \$0.09202/kWh	\$16.38
Fuel Charge	178 kWh @ \$0.03516/kWh	\$6.26
Storm Protection Charge	178 kWh @ \$0.00568/kWh	\$1.01
Clean Energy Transition Mechanism	178 kWh @ \$0.00418/kWh	\$0.74
Storm Surcharge	178 kWh @ \$0.02121/kWh	\$3.78
Florida Gross Receipt Tax		\$1.26
Electric Service Cost		\$50.55
State Tax		\$4.27
Total Electric Cost, Local Fees and Taxes		\$54.82

Avg kWh Used Per Day

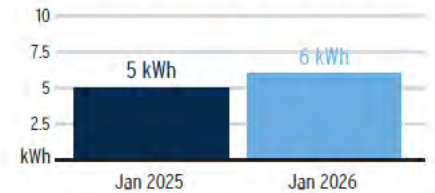

Important Messages

Annual Deposit Interest Credit. This billing statement reflects your annual credit of deposit interest. Thank you for being a valued customer. We appreciate the opportunity to serve you.

Total Current Month's Charges \$54.82

Miscellaneous Credits	
Interest for Cash Security Deposit - Electric	-\$1.20
Total Current Month's Credits	-\$1.20

For more information about your bill and understanding your charges, please visit TampaElectric.com

Ways To Pay Your Bill

- Bank Draft**
Visit TECOaccount.com for free recurring or one time payments via checking or savings account.
- In-Person**
Find list of Payment Agents at TampaElectric.com
- Mail A Check Payments:**
TECO
P.O. Box 31318
Tampa, FL 33631-3318
Mail your payment in the enclosed envelope.
- Credit or Debit Card**
Pay by credit Card using KUBRA EZ-Pay at TECOaccount.com. Convenience fee will be charged.
- Phone**
Toll Free: **866-689-6469**
- All Other Correspondences:**
Tampa Electric
P.O. Box 111
Tampa, FL 33601-0111

Contact Us

- Online:** TampaElectric.com
- Phone:**
Commercial Customer Care: 866-832-6249
Residential Customer Care: 813-223-0800 (Hillsborough)
863-299-0800 (Polk County)
888-223-0800 (All Other Counties)
- Hearing Impaired/TTY: 7-1-1
- Power Outage: 877-588-1010
- Energy-Saving Programs: 813-275-3909

Please Note: If you choose to pay your bill at a location not listed on our website or provided by Tampa Electric, you are paying someone who is not authorized to act as a payment agent at Tampa Electric. You bear the risk that this unauthorized party will relay the payment to Tampa Electric and do so in a timely fashion. Tampa Electric is not responsible for payments made to unauthorized agents, including their failure to deliver or timely deliver the payment to us. Such failures may result in late payment charges to your account or service disconnection.



HARBOR BAY COMMUNITY DEVELOPMENT
 HARBOR BAY CDD-GASLIGHTS
 MIRABAY BLVD, 12 & 3
 APOLLO BEACH, FL 33572-0000

Statement Date: January 29, 2026

Amount Due:	\$352.75
Due Date: February 19, 2026	
Account #: 211009425268	

DO NOT PAY. Your account will be drafted on February 19, 2026

Account Summary

Current Service Period: December 27, 2025 - January 26, 2026	
Previous Amount Due	\$377.89
Payment(s) Received Since Last Statement	-\$371.69
Miscellaneous Credits	-\$6.20
Current Month's Charges	\$352.75
Amount Due by February 19, 2026	\$352.75

Amount not paid by due date may be assessed a late payment charge and an additional deposit.

Your Energy Insight

- Your average daily THMS used was **0% higher** than the same period last year.
- Your average daily THMS used was **.42% lower** than it was in your previous period.



Scan here to view your account online.

Monthly Usage (Therms)

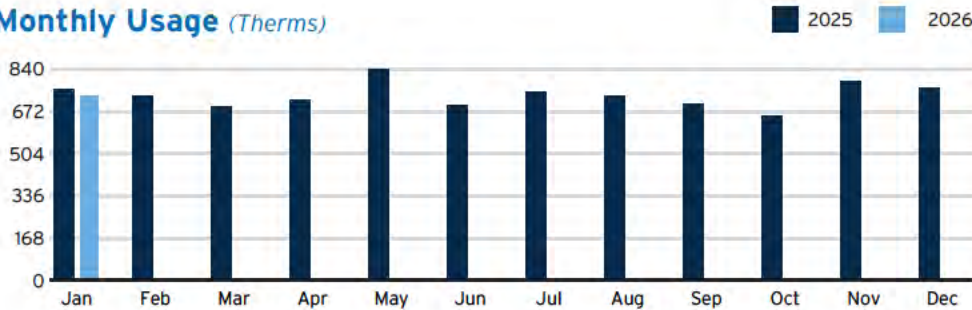

Learn about your newly redesigned bill and get deeper insights about your usage by visiting TECOaccount.com



2026
 New Year, New Ways to Simplify

Get quick text, email or automated call alerts for outages, bills, payments, appointments and more. Just log in and choose the notifications you want.

Get started today at TECOaccount.com.



To ensure prompt credit, please return stub portion of this bill with your payment.

Pay your bill online at PeoplesGas.com
 See reverse side of your paystub for more ways to pay.

Go Paperless, Go Green! Visit PeoplesGas.com/Paperless to enroll now.

Account #: 211009425268
Due Date: February 19, 2026

Amount Due:	\$352.75
Payment Amount:	\$ _____

618051267174

Your account will be drafted on February 19, 2026

HARBOR BAY COMMUNITY DEVELOPMENT
 HARBOR BAY CDD-GASLIGHTS
 250 INTERNATIONAL PKWY, STE 208
 LAKE MARY, FL 32746-5062

Mail payment to:
 TECO
 P.O. BOX 31318
 TAMPA, FL 33631-3318

Make check payable to: TECO
 Please write your account number on the memo line of your check.



Service For:
 MIRABAY BLVD
 12 & 3, APOLLO BEACH, FL 33572-0000

Account #: 211009425268
Statement Date: January 29, 2026
Charges Due: February 19, 2026

Meter Read

Service Period: Dec 27, 2025 - Jan 26, 2026

Rate Schedule: Comm Transportation Street Lighting

Meter Number	Read Date	Current Reading	- Previous Reading	= Measured Volume	x BTU	x Conversion	= Total Used	Billing Period
AHI45086	01/26/2026	8,438	8,294	144 CCF	1.042	1.0000	150.0 Therms	31 Days
AHI58347	01/26/2026	7,900	7,644	256 CCF	1.042	1.0000	266.8 Therms	31 Days
AHX31639	01/26/2026	2,979	2,677	302 CCF	1.042	1.0000	314.7 Therms	31 Days

Charge Details

Natural Gas Charges		
Number of Lights	1	
Distribution Charge	731.5 THMS @ \$0.44126	\$322.78
Swing Service Charge	731.5 THMS @ \$0.01250	\$9.14
Florida Gross Receipts Tax		\$20.83
Natural Gas Service Cost		\$352.75

Total Current Month's Charges \$352.75

Miscellaneous Credits		
Interest for Cash Security Deposit - Gas		-\$6.20
Total Current Month's Credits		-\$6.20

Avg THMS Used Per Day

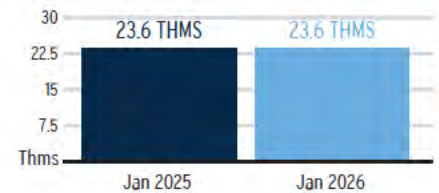

Important Messages

The billing periods of the individual meters of a multi-metered account may differ from the dates displayed. All the meters on such an account may not have been read on the same date due to their location on the property.

Annual Deposit Interest Credit. This billing statement reflects your annual credit of deposit interest. Thank you for being a valued customer. We appreciate the opportunity to serve you.

For more information about your bill and understanding your charges, please visit PeoplesGas.com

Ways To Pay Your Bill

- Bank Draft**
 Visit PeoplesGas.com for free recurring or one time payments via checking or savings account.
- In-Person**
 Find list of Payment Agents at PeoplesGas.com
- Mail A Check**
Payments:
 TECO
 P.O. Box 31318
 Tampa, FL 33631-3318
 Mail your payment in the enclosed envelope.
- Credit or Debit Card**
 Pay by credit Card using KUBRA EZ-Pay at PeoplesGas.com. Convenience fee will be charged.
- Phone**
 Toll Free: **866-689-6469**
- All Other Correspondences:**
 Peoples Gas
 P.O. Box 111
 Tampa, FL 33601-0111

Contact Us

- Residential Customer Care:**
- 813-223-0800 (Tampa)
- 863-299-0800 (Lakeland)
- 352-622-0111 (Ocala)
- 954-453-0777 (Broward)
- 305-940-0139 (Miami)
- 727-826-3333 (St. Petersburg)
- 407-425-4662 (Orlando)
- 904-739-1211 (Jacksonville)
- 877-832-6747 (All Other Counties)
- Online:**
PeoplesGas.com
- Phone:**
 Commercial Customer Care: 866-832-6249
 Hearing Impaired/TTY: 7-1-1
 Natural Gas Outage: 877-832-6747
 Natural Gas Energy Conservation Rebates: 877-832-6747

Please Note: If you choose to pay your bill at a location not listed on our website or provided by Peoples Gas, you are paying someone who is not authorized to act as a payment agent at Peoples Gas. You bear the risk that this unauthorized party will relay the payment to Peoples Gas and do so in a timely fashion. Peoples Gas is not responsible for payments made to unauthorized agents, including their failure to deliver or timely deliver the payment to us. Such failures may result in late payment charges to your account or service disconnection.



HARBOR BAY COMMUNITY DEVELOPMENT
5127 COASTAL SCENE DR
APOLLO BEACH, FL 33572-3432

Statement Date: January 29, 2026

Amount Due:	\$152.85
Due Date: February 19, 2026	
Account #: 221006323390	

DO NOT PAY. Your account will be drafted on February 19, 2026

Account Summary

Current Service Period: December 23, 2025 - January 23, 2026	
Previous Amount Due	\$139.86
Payment(s) Received Since Last Statement	-\$137.84
Miscellaneous Credits	-\$2.02
Current Month's Charges	\$152.85
Amount Due by February 19, 2026	\$152.85

Amount not paid by due date may be assessed a late payment charge and an additional deposit.

Your Energy Insight

- Your average daily kWh used was **76.92% higher** than the same period last year.
- Your average daily kWh used was **4.55% higher** than it was in your previous period.

Scan here to view your account online.

2026
New Year, New Ways to Simplify

Get quick text, email or automated call alerts for outages, bills, payments, appointments and more. Just log in and choose the notifications you want.

Get started today at TECOaccount.com.

Monthly Usage (kWh)

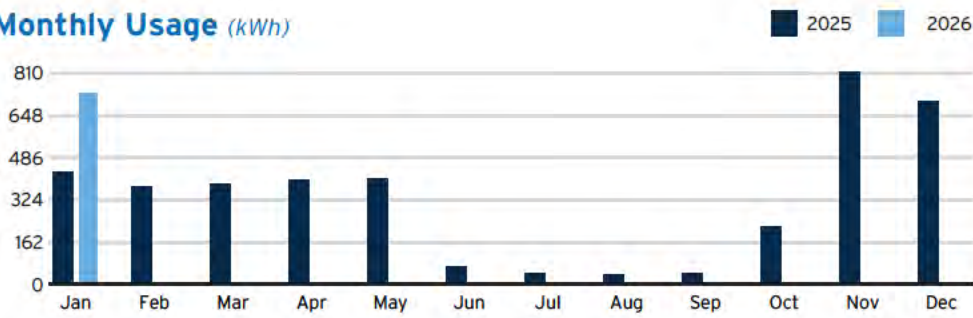

Learn about your newly redesigned bill and get deeper insights about your usage by visiting TECOaccount.com

To ensure prompt credit, please return stub portion of this bill with your payment.



Pay your bill online at TampaElectric.com
See reverse side of your paystub for more ways to pay.
Go Paperless, Go Green! Visit TampaElectric.com/Paperless to enroll now.

Account #: 221006323390
Due Date: February 19, 2026

Amount Due:	\$152.85
Payment Amount:	\$ _____

613113022114
Your account will be drafted on February 19, 2026

HARBOR BAY COMMUNITY DEVELOPMENT
250 INTERNATIONAL PKWY, STE 208
LAKE MARY, FL 32746-5062

Mail payment to:
TECO
P.O. BOX 31318
TAMPA, FL 33631-3318

Make check payable to: TECO
Please write your account number on the memo line of your check.



Service For:
5127 COASTAL SCENE DR
APOLLO BEACH, FL 33572-3432

Account #: 221006323390
Statement Date: January 29, 2026
Charges Due: February 19, 2026

Meter Read

Service Period: Dec 23, 2025 - Jan 23, 2026

Rate Schedule: General Service - Non Demand

Meter Number	Read Date	Current Reading	Previous Reading	=	Total Used	Multiplier	Billing Period
1000851762	01/23/2026	14,352	13,617		735 kWh	1	32 Days

Charge Details

Electric Charges		
Daily Basic Service Charge	32 days @ \$0.66000	\$21.12
Energy Charge	735 kWh @ \$0.09202/kWh	\$67.63
Fuel Charge	735 kWh @ \$0.03516/kWh	\$25.84
Storm Protection Charge	735 kWh @ \$0.00568/kWh	\$4.17
Clean Energy Transition Mechanism	735 kWh @ \$0.00418/kWh	\$3.07
Storm Surcharge	735 kWh @ \$0.02121/kWh	\$15.59
Florida Gross Receipt Tax		\$3.52
Electric Service Cost		\$140.94
State Tax		\$11.91
Total Electric Cost, Local Fees and Taxes		\$152.85

Avg kWh Used Per Day

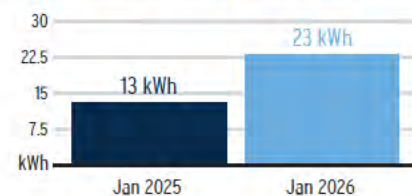

Important Messages

Annual Deposit Interest Credit. This billing statement reflects your annual credit of deposit interest. Thank you for being a valued customer. We appreciate the opportunity to serve you.

Total Current Month's Charges \$152.85

Miscellaneous Credits	
Interest for Cash Security Deposit - Electric	-\$2.02
Total Current Month's Credits	-\$2.02

For more information about your bill and understanding your charges, please visit TampaElectric.com

Ways To Pay Your Bill

- Bank Draft**
Visit TECOaccount.com for free recurring or one time payments via checking or savings account.
- In-Person**
Find list of Payment Agents at TampaElectric.com
- Mail A Check Payments:**
TECO
P.O. Box 31318
Tampa, FL 33631-3318
Mail your payment in the enclosed envelope.
- Credit or Debit Card**
Pay by credit Card using KUBRA EZ-Pay at TECOaccount.com. Convenience fee will be charged.
- Phone**
Toll Free: **866-689-6469**
- All Other Correspondences:**
Tampa Electric
P.O. Box 111
Tampa, FL 33601-0111

Contact Us

- Online:** TampaElectric.com
- Phone:** Commercial Customer Care: 866-832-6249
Residential Customer Care: 813-223-0800 (Hillsborough)
863-299-0800 (Polk County)
888-223-0800 (All Other Counties)
- Hearing Impaired/TTY: 7-1-1
- Power Outage: 877-588-1010
- Energy-Saving Programs: 813-275-3909

Please Note: If you choose to pay your bill at a location not listed on our website or provided by Tampa Electric, you are paying someone who is not authorized to act as a payment agent at Tampa Electric. You bear the risk that this unauthorized party will relay the payment to Tampa Electric and do so in a timely fashion. Tampa Electric is not responsible for payments made to unauthorized agents, including their failure to deliver or timely deliver the payment to us. Such failures may result in late payment charges to your account or service disconnection.



HARBOR BAY COMMUNITY DEVELOPMENT
107 MANNS HARBOR DR, LS2
APOLLO BEACH, FL 33572-3340

Statement Date: January 29, 2026

Amount Due: \$11,529.74

Due Date: February 19, 2026

Account #: 221008458756

DO NOT PAY. Your account will be drafted on February 19, 2026

Account Summary

Current Service Period: December 23, 2025 - January 23, 2026	
Previous Amount Due	\$11,525.64
Payment(s) Received Since Last Statement	-\$11,525.64
Current Month's Charges	\$11,529.74
Amount Due by February 19, 2026	\$11,529.74

Amount not paid by due date may be assessed a late payment charge and an additional deposit.

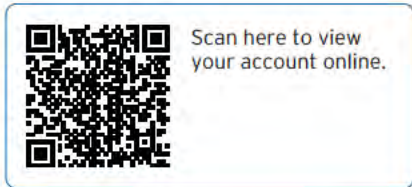

Scan here to view your account online.



Get quick text, email or automated call alerts for outages, bills, payments, appointments and more. Just log in and choose the notifications you want.

Get started today at TECOaccount.com.

Learn about your newly redesigned bill and get deeper insights about your usage by visiting TECOaccount.com



To ensure prompt credit, please return stub portion of this bill with your payment.

Account #: 221008458756

Due Date: February 19, 2026

Pay your bill online at TampaElectric.com
See reverse side of your paystub for more ways to pay.

Go Paperless, Go Green! Visit TampaElectric.com/Paperless to enroll now.

Amount Due:	\$11,529.74
Payment Amount: \$	_____

676075695833

Your account will be drafted on February 19, 2026

HARBOR BAY COMMUNITY DEVELOPMENT
4648 EAGLE FALLS PL
TAMPA, FL 33619-9613

Mail payment to:
TECO
P.O. BOX 31318
TAMPA, FL 33631-3318

Make check payable to: TECO
Please write your account number on the memo line of your check.



Service For:
 107 MANN'S HARBOR DR
 LS2, APOLLO BEACH, FL 33572-3340

Account #: 221008458756
Statement Date: January 29, 2026
Charges Due: February 19, 2026

Service Period: Dec 23, 2025 - Jan 23, 2026

Rate Schedule: LS-2 Customer Specified Lighting

Charge Details

Electric Charges		
Lighting Service Items LS-2 (Bright Choices) for 32 days		
Lighting Energy Charge	3573 kWh @ \$0.03411/kWh	\$121.88
Monthly Charge		\$10479.78
Lighting Fuel Charge	3573 kWh @ \$0.03452/kWh	\$123.34
Storm Protection Charge	3573 kWh @ \$0.00574/kWh	\$20.51
Clean Energy Transition Mechanism	3573 kWh @ \$0.00043/kWh	\$1.54
Storm Surcharge	3573 kWh @ \$0.01230/kWh	\$43.95
Florida Gross Receipt Tax		\$7.98
State Tax		\$730.76
Lighting Charges		\$11,529.74

Total Current Month's Charges **\$11,529.74**

For more information about your bill and understanding your charges, please visit TampaElectric.com

Ways To Pay Your Bill

- Bank Draft**
 Visit TECOaccount.com for free recurring or one time payments via checking or savings account.
- In-Person**
 Find list of Payment Agents at TampaElectric.com
- Mail A Check**
Payments:
 TECO
 P.O. Box 31318
 Tampa, FL 33631-3318
 Mail your payment in the enclosed envelope.
- Credit or Debit Card**
 Pay by credit Card using KUBRA EZ-Pay at TECOaccount.com. Convenience fee will be charged.
- Phone**
 Toll Free: **866-689-6469**
- All Other Correspondences:**
 Tampa Electric
 P.O. Box 111
 Tampa, FL 33601-0111

Contact Us

- Online:**
TampaElectric.com
- Phone:**
Commercial Customer Care: 866-832-6249
Residential Customer Care: 813-223-0800 (Hillsborough)
 863-299-0800 (Polk County)
 888-223-0800 (All Other Counties)
- Hearing Impaired/TTY:** 7-1-1
- Power Outage:** 877-588-1010
- Energy-Saving Programs:** 813-275-3909

Please Note: If you choose to pay your bill at a location not listed on our website or provided by Tampa Electric, you are paying someone who is not authorized to act as a payment agent at Tampa Electric. You bear the risk that this unauthorized party will relay the payment to Tampa Electric and do so in a timely fashion. Tampa Electric is not responsible for payments made to unauthorized agents, including their failure to deliver or timely deliver the payment to us. Such failures may result in late payment charges to your account or service disconnection.



HARBOR BAY COMMUNITY DEVELOPMENT
4530 EAGLE FALLS PL,
TAMPA, FL 33619-9611

Statement Date: February 05, 2026

Amount Due: \$10,546.34

Due Date: February 19, 2026

Account #: 311000030115

DO NOT PAY. Your account will be drafted on February 19, 2026

Your Locations With The Highest Usage

- 107 MANN'S HARBOR DR, APOLLO BEACH, FL 33572-3340 **43,394 KWH**
- 5496 N US HWY 41, APOLLO BEACH, FL 33572-0000 **11,643 KWH**

Account Summary

Previous Amount Due	\$13,732.53
Payment(s) Received Since Last Statement	-\$13,732.53
Credit Balance After Payments and Credits	\$0.00
Current Month's Charges	\$10,546.34

Amount Due by February 19, 2026 \$10,546.34

Amount not paid by due date may be assessed a late payment charge and an additional deposit.

Scan here to interact with your bill online.

Monthly Usage (kWh)

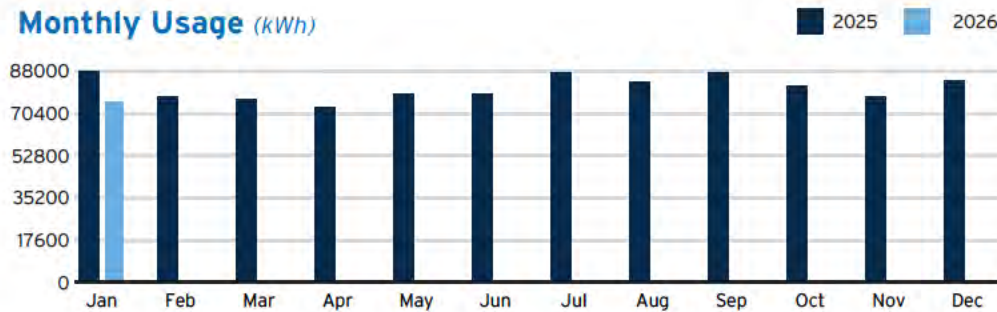

Learn about your newly redesigned bill and get deeper insights about your usage by visiting TECOaccount.com

DOWNED IS DANGEROUS!

If you see a downed power line, move a safe distance away and call 911.

Visit TampaElectric.com/Safety for more safety tips.



To ensure prompt credit, please return stub portion of this bill with your payment.

Account #: 311000030115

Due Date: February 19, 2026

Pay your bill online at TampaElectric.com
See reverse side of your paystub for more ways to pay.

Go Paperless, Go Green! Visit TampaElectric.com/Paperless to enroll now.

Amount Due: \$10,546.34

Payment Amount: \$ _____

700125004580

Your account will be drafted on February 19, 2026

HARBOR BAY COMMUNITY DEVELOPMENT
4530 EAGLE FALLS PL
TAMPA, FL 33619-9611

Mail payment to:
TECO
P.O. BOX 31318
TAMPA, FL 33631-3318

Make check payable to: TECO
Please write your account number on the memo line of your check.

Summary of Charges by Service Address

Account Number: 311000030115

Energy Usage From Last Month

▲ Increased
 = Same
 ▼ Decreased

Service Address: MIRA BAY PARCEL 12-A-2, APOLLO BEACH, FL 33572-0000

Sub-Account Number: 211010865395

Amount: \$371.90

Service Address: 5496 N US HWY 41, APOLLO BEACH, FL 33572-0000

Sub-Account Number: 211009335491

Meter	Read Date	Current	-	Previous	=	Total Used	Multiplier	Billing Period	Amount
1000853274	01/23/2026	46,022		45,060		962 kWh	1	32 Days	\$192.80
									▼ 49.5%

Service Address: 5496 N US HWY 41, APOLLO BEACH, FL 33572-0000

Sub-Account Number: 211009335905

Meter	Read Date	Current	-	Previous	=	Total Used	Multiplier	Billing Period	Amount
1000798616	01/23/2026	99,620		87,977		11,643 kWh	1	32 Days	\$1,377.87
1000798616	01/23/2026	23.7		0		23.7 kW	1	32 Days	\$3.80
									▲ 3.8%

Service Address: 107 MANNS HARBOR DR, C, APOLLO BEACH, FL 33572-3340

Sub-Account Number: 211009336101

Meter	Read Date	Current	-	Previous	=	Total Used	Multiplier	Billing Period	Amount
1000780649	01/23/2026	63,226		62,201		1,025 kWh	1	32 Days	\$203.91
									▼ 27.9%

Continued on next page →

For more information about your bill and understanding your charges, please visit TampaElectric.com

Ways To Pay Your Bill



Bank Draft

Visit TECOaccount.com for free recurring or one time payments via checking or savings account.



In-Person

Find list of Payment Agents at TampaElectric.com



Mail A Check

Payments:
TECO
P.O. Box 31318
Tampa, FL 33631-3318
Mail your payment in the enclosed envelope.



Credit or Debit Card

Pay by credit Card using KUBRA EZ-Pay at TECOaccount.com. Convenience fee will be charged.



Phone

Toll Free: **866-689-6469**

All Other

Correspondences:
Tampa Electric
P.O. Box 111
Tampa, FL 33601-0111

Contact Us

Online:
TampaElectric.com

Phone:
Commercial Customer Care:
866-832-6249
Residential Customer Care:
813-223-0800 (Hillsborough)
863-299-0800 (Polk County)
888-223-0800 (All Other Counties)

Hearing Impaired/TTY:
7-1-1
Power Outage:
877-588-1010
Energy-Saving Programs:
813-275-3909

Please Note: If you choose to pay your bill at a location not listed on our website or provided by Tampa Electric, you are paying someone who is not authorized to act as a payment agent at Tampa Electric. You bear the risk that this unauthorized party will relay the payment to Tampa Electric and do so in a timely fashion. Tampa Electric is not responsible for payments made to unauthorized agents, including their failure to deliver or timely deliver the payment to us. Such failures may result in late payment charges to your account or service disconnection.

Summary of Charges by Service Address

Account Number: 311000030115

Energy Usage From Last Month

▲ Increased
 = Same
 ▼ Decreased

Service Address: 300 MANNS HARBOR DR, 2, APOLLO BEACH, FL 33572-3343

Sub-Account Number: 211009336770

Meter	Read Date	Current	-	Previous	=	Total Used	Multiplier	Billing Period	Amount	
1000688868	01/23/2026	67,680		67,014		666 kWh	1	32 Days	\$140.72	▲ 1.5%

Service Address: 200 MIRABAY BLVD, 1, APOLLO BEACH, FL 33572-0000

Sub-Account Number: 211009336960

Meter	Read Date	Current	-	Previous	=	Total Used	Multiplier	Billing Period	Amount	
1000550784	01/23/2026	50,543		49,607		936 kWh	1	32 Days	\$188.25	▼ 5.6%

Service Address: 858 MANNS HARBOR DR, APOLLO BEACH, FL 33572-3393

Sub-Account Number: 211009337638

Meter	Read Date	Current	-	Previous	=	Total Used	Multiplier	Billing Period	Amount	
1000851679	01/23/2026	2,765		1,749		1,016 kWh	1	32 Days	\$202.32	▲ 2.2%

Service Address: 107 MANNS HARBOR DR, A, APOLLO BEACH, FL 33572-3340

Sub-Account Number: 211009337919

Meter	Read Date	Current	-	Previous	=	Total Used	Multiplier	Billing Period	Amount	
1000771954	01/23/2026	7,830		7,767		10,080 kWh	160.0000	32 Days	\$2,049.11	
1000771954	01/23/2026	0.33		0		52.96 kW	160.0000	32 Days		▼ 42.2%

Service Address: 428 MIRABAY BLVD, APOLLO BEACH, FL 33572-3311

Sub-Account Number: 211009338149

Meter	Read Date	Current	-	Previous	=	Total Used	Multiplier	Billing Period	Amount	
1000852666	01/23/2026	89,796		88,119		1,677 kWh	1	32 Days	\$318.69	▲ 24.3%

Service Address: 103 MIRABAY BLVD, APOLLO BEACH, FL 33572-3346

Sub-Account Number: 211009338354

Meter	Read Date	Current	-	Previous	=	Total Used	Multiplier	Billing Period	Amount	
1000769621	01/23/2026	54,514		53,279		1,235 kWh	1	32 Days	\$240.86	▼ 15.8%

Service Address: 107 MANNS HARBOR DR, APOLLO BEACH, FL 33572-3340

Sub-Account Number: 211009338560

Meter	Read Date	Current	-	Previous	=	Total Used	Multiplier	Billing Period	Amount	
1000780652	01/23/2026	83,123		39,729		43,394 kWh	1	32 Days	\$4,539.48	
1000780652	01/23/2026	70.82		0		70.82 kW	1	32 Days		▲ 0.4%

Continued on next page →

Summary of Charges by Service Address

Account Number: 311000030115

Energy Usage From Last Month

▲ Increased
 = Same
▼ Decreased

Service Address: 211 IBISVIEW LN LGHT, APOLLO BEACH, FL 33572-0000					Sub-Account Number: 211009338982				
Meter	Read Date	Current	-	Previous	=	Total Used	Multiplier	Billing Period	Amount
1000432342	01/23/2026	355		353		2 kWh	1	32 Days	\$23.84
									= 0.0%

Service Address: 107 MANNS HARBOR DR, B, APOLLO BEACH, FL 33572-3340					Sub-Account Number: 211009339162				
Meter	Read Date	Current	-	Previous	=	Total Used	Multiplier	Billing Period	Amount
1000967419	01/23/2026	600		521		79 kWh	1	32 Days	\$37.40
									▲ 1.3%

Service Address: 605 MIRABAY BLVD, APOLLO BEACH, FL 33572-3379					Sub-Account Number: 211009420376				
Meter	Read Date	Current	-	Previous	=	Total Used	Multiplier	Billing Period	Amount
1000852706	01/23/2026	2,891		2,829		62 kWh	1	32 Days	\$34.41
									▲ 3.3%

Service Address: 449 ISLEBAY DR, APOLLO BEACH, FL 33572-3332					Sub-Account Number: 211009420731				
Meter	Read Date	Current	-	Previous	=	Total Used	Multiplier	Billing Period	Amount
1000426126	01/23/2026	6,617		6,526		91 kWh	1	32 Days	\$39.51
									▲ 1.1%

Service Address: 5633 SKIMMER DR, APOLLO BEACH, FL 33572-3353					Sub-Account Number: 211009420921				
Meter	Read Date	Current	-	Previous	=	Total Used	Multiplier	Billing Period	Amount
1000426250	01/23/2026	11,964		11,735		229 kWh	1	32 Days	\$63.80
									▼ 2.1%

Service Address: 5424 MERRITT ISLAND DR, APOLLO BEACH, FL 33572-3375					Sub-Account Number: 211009421739				
Meter	Read Date	Current	-	Previous	=	Total Used	Multiplier	Billing Period	Amount
1000600632	01/23/2026	5,581		5,448		133 kWh	1	32 Days	\$46.92
									▲ 9.9%

Service Address: 191 MIRABAY BLVD, APOLLO BEACH, FL 33572-3346					Sub-Account Number: 211009421929				
Meter	Read Date	Current	-	Previous	=	Total Used	Multiplier	Billing Period	Amount
1000769622	01/23/2026	47,587		46,107		1,480 kWh	1	32 Days	\$284.02
									▲ 4.0%

Continued on next page →

Summary of Charges by Service Address

Account Number: 311000030115

Energy Usage From Last Month

Increased
 Same
 Decreased

Service Address: 5423 TYBEE ISLAND DR, APOLLO BEACH, FL 33572-3307

Sub-Account Number: 211009422786

Meter	Read Date	Current	-	Previous	=	Total Used	Multiplier	Billing Period	Amount
1000580302	01/23/2026	4,389		4,314		75 kWh	1	32 Days	\$36.70
									<input type="checkbox"/> 3.8%

Service Address: 804 ISLEBAY DR, APOLLO BEACH, FL 33572-3380

Sub-Account Number: 211009423289

Meter	Read Date	Current	-	Previous	=	Total Used	Multiplier	Billing Period	Amount
1000430259	01/23/2026	3,883		3,827		56 kWh	1	32 Days	\$33.35
									<input type="checkbox"/> 24.3%

Service Address: 564 MANNS HARBOR DR, APOLLO BEACH, FL 33572-3330

Sub-Account Number: 211009423438

Meter	Read Date	Current	-	Previous	=	Total Used	Multiplier	Billing Period	Amount
1000428233	01/23/2026	30,436		29,885		551 kWh	1	32 Days	\$120.48
									<input checked="" type="checkbox"/> 15.0%

Service Address: 107 MANNS HARBOR DR, D, APOLLO BEACH, FL 33572-3340

Sub-Account Number: 211009422976

UNBILLED ACCOUNT

Total Current Month's Charges

\$10,546.34



Sub-Account #: 211010865395
Statement Date: 02/02/2026

Service Address: MIRA BAY PARCEL 12-A-2, APOLLO BEACH, FL 33572-0000

Service Period: 12/23/2025 - 01/23/2026

Rate Schedule: Lighting Service

Charge Details



Electric Charges

Lighting Service Items LS-1 (Bright Choices) for 32 days

Lighting Energy Charge	138 kWh @ \$0.03411/kWh	\$4.71
Fixture & Maintenance Charge	7 Fixtures	\$135.28
Lighting Pole / Wire	7 Poles	\$198.24
Lighting Fuel Charge	138 kWh @ \$0.03452/kWh	\$4.76
Storm Protection Charge	138 kWh @ \$0.00574/kWh	\$0.79
Clean Energy Transition Mechanism	138 kWh @ \$0.00043/kWh	\$0.06
Storm Surcharge	138 kWh @ \$0.01230/kWh	\$1.70
Florida Gross Receipt Tax		\$0.31
State Tax		\$26.05

Lighting Charges **\$371.90**

Current Month's Electric Charges

\$371.90

Billing information continues on next page →



Sub-Account #: 211009335491
Statement Date: 02/02/2026

Service Address: 5496 N US HWY 41, APOLLO BEACH, FL 33572-0000

Meter Read

Service Period: 12/23/2025 - 01/23/2026

Rate Schedule: General Service - Non Demand

Meter Number	Read Date	Current Reading	Previous Reading	=	Total Used	Multiplier	Billing Period
1000853274	01/23/2026	46,022	45,060		962 kWh	1	32 Days

Charge Details

⚡ Electric Charges		
Daily Basic Service Charge	32 days @ \$0.66000	\$21.12
Energy Charge	962 kWh @ \$0.09202/kWh	\$88.52
Fuel Charge	962 kWh @ \$0.03516/kWh	\$33.82
Storm Protection Charge	962 kWh @ \$0.00568/kWh	\$5.46
Clean Energy Transition Mechanism	962 kWh @ \$0.00418/kWh	\$4.02
Storm Surcharge	962 kWh @ \$0.02121/kWh	\$20.40
Florida Gross Receipt Tax		\$4.44
Electric Service Cost		\$177.78
State Tax		\$15.02
Total Electric Cost, Local Fees and Taxes		\$192.80

Avg kWh Used Per Day

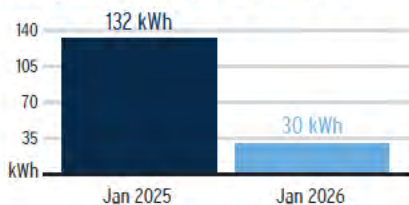

Current Month's Electric Charges \$192.80

Billing information continues on next page →



Sub-Account #: 211009335905
Statement Date: 02/02/2026

Service Address: 5496 N US HWY 41, APOLLO BEACH, FL 33572-0000

Meter Read

Service Period: 12/23/2025 - 01/23/2026

Rate Schedule: General Service Demand - Standard

Meter Number	Read Date	Current Reading	Previous Reading	= Total Used	Multiplier	Billing Period
1000798616	01/23/2026	99,620	87,977	11,643 kWh	1	32 Days
1000798616	01/23/2026	23.7	0	23.7 kW	1	32 Days

Charge Details

Electric Charges		
Daily Basic Service Charge	32 days @ \$1.12000	\$35.84
Billing Demand Charge	24 kW @ \$19.06000/kW	\$457.44
Energy Charge	11,643 kWh @ \$0.00815/kWh	\$94.89
Fuel Charge	11,643 kWh @ \$0.03516/kWh	\$409.37
Capacity Charge	24 kW @ \$0.72000/kW	\$17.28
Storm Protection Charge	24 kW @ \$2.02000/kW	\$48.48
Energy Conservation Charge	24 kW @ \$0.79000/kW	\$18.96
Environmental Cost Recovery	11,643 kWh @ \$0.00072/kWh	\$8.38
Clean Energy Transition Mechanism	24 kW @ \$1.15000/kW	\$27.60
Storm Surcharge	11,643 kWh @ \$0.01035/kWh	\$120.51
Florida Gross Receipt Tax		\$31.76
Electric Service Cost		\$1,270.51
State Tax		\$107.36
Total Electric Cost, Local Fees and Taxes		\$1,377.87

Avg kWh Used Per Day

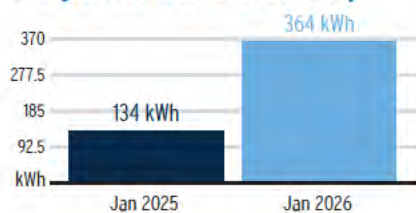

Billing Demand (kW)

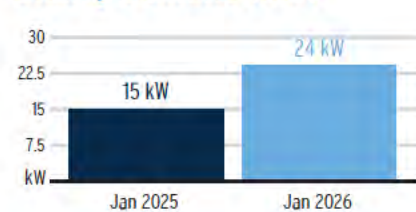

Load Factor



Decreasing the proportion of your electricity utilized at peak will improve your load factor.

Current Month's Electric Charges \$1,377.87

Billing information continues on next page →



Sub-Account #: 211009336101
Statement Date: 02/02/2026

Service Address: 107 MANNS HARBOR DR, C, APOLLO BEACH, FL 33572-3340

Meter Read

Meter Location: # C

Service Period: 12/23/2025 - 01/23/2026

Rate Schedule: General Service - Non Demand

Meter Number	Read Date	Current Reading	-	Previous Reading	=	Total Used	Multiplier	Billing Period
1000780649	01/23/2026	63,226		62,201		1,025 kWh	1	32 Days

Charge Details

Electric Charges		
Daily Basic Service Charge	32 days @ \$0.66000	\$21.12
Energy Charge	1,025 kWh @ \$0.09202/kWh	\$94.32
Fuel Charge	1,025 kWh @ \$0.03516/kWh	\$36.04
Storm Protection Charge	1,025 kWh @ \$0.00568/kWh	\$5.82
Clean Energy Transition Mechanism	1,025 kWh @ \$0.00418/kWh	\$4.28
Storm Surcharge	1,025 kWh @ \$0.02121/kWh	\$21.74
Florida Gross Receipt Tax		\$4.70
Electric Service Cost		\$188.02
State Tax		\$15.89
Total Electric Cost, Local Fees and Taxes		\$203.91

Avg kWh Used Per Day

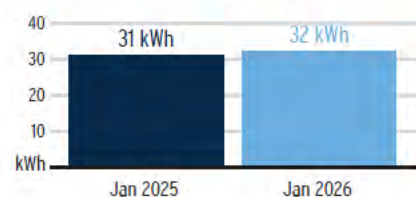

Current Month's Electric Charges \$203.91

Billing information continues on next page →



Sub-Account #: 211009336770
Statement Date: 02/02/2026

Service Address: 300 MANNS HARBOR DR, 2, APOLLO BEACH, FL 33572-3343

Meter Read

Meter Location: # 2

Service Period: 12/23/2025 - 01/23/2026

Rate Schedule: General Service - Non Demand

Meter Number	Read Date	Current Reading	-	Previous Reading	=	Total Used	Multiplier	Billing Period
1000688868	01/23/2026	67,680		67,014		666 kWh	1	32 Days

Charge Details

⚡ Electric Charges		
Daily Basic Service Charge	32 days @ \$0.66000	\$21.12
Energy Charge	666 kWh @ \$0.09202/kWh	\$61.29
Fuel Charge	666 kWh @ \$0.03516/kWh	\$23.42
Storm Protection Charge	666 kWh @ \$0.00568/kWh	\$3.78
Clean Energy Transition Mechanism	666 kWh @ \$0.00418/kWh	\$2.78
Storm Surcharge	666 kWh @ \$0.02121/kWh	\$14.13
Florida Gross Receipt Tax		\$3.24
Electric Service Cost		\$129.76
State Tax		\$10.96
Total Electric Cost, Local Fees and Taxes		\$140.72

Avg kWh Used Per Day

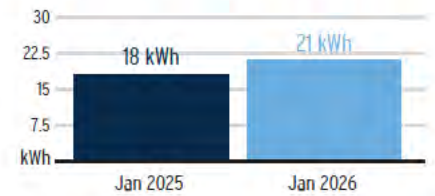

Current Month's Electric Charges \$140.72

Billing information continues on next page →



Sub-Account #: 211009336960
Statement Date: 02/02/2026

Service Address: 200 MIRABAY BLVD, 1, APOLLO BEACH, FL 33572-0000

Meter Read

Meter Location: # 1

Service Period: 12/23/2025 - 01/23/2026

Rate Schedule: General Service - Non Demand

Meter Number	Read Date	Current Reading	-	Previous Reading	=	Total Used	Multiplier	Billing Period
1000550784	01/23/2026	50,543		49,607		936 kWh	1	32 Days

Charge Details

Electric Charges		
Daily Basic Service Charge	32 days @ \$0.66000	\$21.12
Energy Charge	936 kWh @ \$0.09202/kWh	\$86.13
Fuel Charge	936 kWh @ \$0.03516/kWh	\$32.91
Storm Protection Charge	936 kWh @ \$0.00568/kWh	\$5.32
Clean Energy Transition Mechanism	936 kWh @ \$0.00418/kWh	\$3.91
Storm Surcharge	936 kWh @ \$0.02121/kWh	\$19.85
Florida Gross Receipt Tax		\$4.34
Electric Service Cost		\$173.58
State Tax		\$14.67
Total Electric Cost, Local Fees and Taxes		\$188.25

Avg kWh Used Per Day

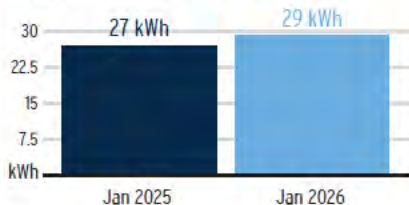

Current Month's Electric Charges \$188.25

Billing information continues on next page →



Sub-Account #: 211009337638
Statement Date: 02/02/2026

Service Address: 858 MANNS HARBOR DR, APOLLO BEACH, FL 33572-3393

Meter Read

Service Period: 12/23/2025 - 01/23/2026

Rate Schedule: General Service - Non Demand

Meter Number	Read Date	Current Reading	-	Previous Reading	=	Total Used	Multiplier	Billing Period
1000851679	01/23/2026	2,765		1,749		1,016 kWh	1	32 Days

Charge Details

⚡ Electric Charges		
Daily Basic Service Charge	32 days @ \$0.66000	\$21.12
Energy Charge	1,016 kWh @ \$0.09202/kWh	\$93.49
Fuel Charge	1,016 kWh @ \$0.03516/kWh	\$35.72
Storm Protection Charge	1,016 kWh @ \$0.00568/kWh	\$5.77
Clean Energy Transition Mechanism	1,016 kWh @ \$0.00418/kWh	\$4.25
Storm Surcharge	1,016 kWh @ \$0.02121/kWh	\$21.55
Florida Gross Receipt Tax		\$4.66
Electric Service Cost		\$186.56
State Tax		\$15.76
Total Electric Cost, Local Fees and Taxes		\$202.32

Avg kWh Used Per Day

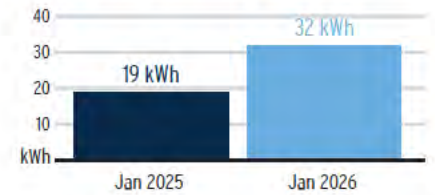

Current Month's Electric Charges \$202.32

Billing information continues on next page →



Sub-Account #: 211009337919
Statement Date: 02/02/2026

Service Address: 107 MANNS HARBOR DR, A, APOLLO BEACH, FL 33572-3340

Meter Read

Meter Location: # A Clu H

Service Period: 12/23/2025 - 01/23/2026

Rate Schedule: General Service Demand - Standard

Meter Number	Read Date	Current Reading	- Previous Reading	= Total Used	Multiplier	Billing Period
1000771954	01/23/2026	7,830	7,767	10,080 kWh	160.0000	32 Days
1000771954	01/23/2026	0.33	0	52.96 kW	160.0000	32 Days

Charge Details

Electric Charges		
Daily Basic Service Charge	32 days @ \$1.12000	\$35.84
Billing Demand Charge	53 kW @ \$19.06000/kW	\$1,010.18
Energy Charge	10,080 kWh @ \$0.00815/kWh	\$82.15
Fuel Charge	10,080 kWh @ \$0.03516/kWh	\$354.41
Capacity Charge	53 kW @ \$0.72000/kW	\$38.16
Storm Protection Charge	53 kW @ \$2.02000/kW	\$107.06
Energy Conservation Charge	53 kW @ \$0.79000/kW	\$41.87
Environmental Cost Recovery	10,080 kWh @ \$0.00072/kWh	\$7.26
Clean Energy Transition Mechanism	53 kW @ \$1.15000/kW	\$60.95
Storm Surcharge	10,080 kWh @ \$0.01035/kWh	\$104.33
Florida Gross Receipt Tax		\$47.24
Electric Service Cost		\$1,889.45
State Tax		\$159.66
Total Electric Cost, Local Fees and Taxes		\$2,049.11

Current Month's Electric Charges \$2,049.11

Billing information continues on next page →

Avg kWh Used Per Day

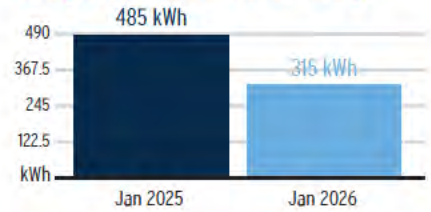

Billing Demand (kW)

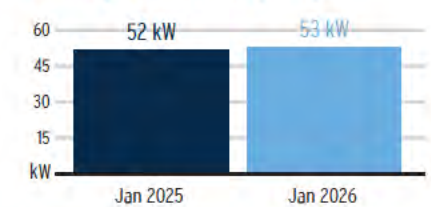

Load Factor



Decreasing the proportion of your electricity utilized at peak will improve your load factor.



Sub-Account #: 211009338149
Statement Date: 02/02/2026

Service Address: 428 MIRABAY BLVD, APOLLO BEACH, FL 33572-3311

Meter Read

Meter Location: Pmp

Service Period: 12/23/2025 - 01/23/2026

Rate Schedule: General Service - Non Demand

Meter Number	Read Date	Current Reading	-	Previous Reading	=	Total Used	Multiplier	Billing Period
1000852666	01/23/2026	89,796		88,119		1,677 kWh	1	32 Days

Charge Details

Electric Charges		
Daily Basic Service Charge	32 days @ \$0.66000	\$21.12
Energy Charge	1,677 kWh @ \$0.09202/kWh	\$154.32
Fuel Charge	1,677 kWh @ \$0.03516/kWh	\$58.96
Storm Protection Charge	1,677 kWh @ \$0.00568/kWh	\$9.53
Clean Energy Transition Mechanism	1,677 kWh @ \$0.00418/kWh	\$7.01
Storm Surcharge	1,677 kWh @ \$0.02121/kWh	\$35.57
Florida Gross Receipt Tax		\$7.35
Electric Service Cost		\$293.86
State Tax		\$24.83
Total Electric Cost, Local Fees and Taxes		\$318.69

Avg kWh Used Per Day

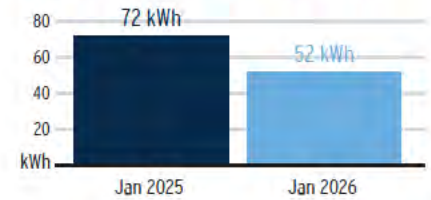

Current Month's Electric Charges \$318.69

Billing information continues on next page →



Sub-Account #: 211009338354
Statement Date: 02/02/2026

Service Address: 103 MIRABAY BLVD, APOLLO BEACH, FL 33572-3346

Meter Read

Meter Location: Tennis

Service Period: 12/23/2025 - 01/23/2026

Rate Schedule: General Service - Non Demand

Meter Number	Read Date	Current Reading	-	Previous Reading	=	Total Used	Multiplier	Billing Period
1000769621	01/23/2026	54,514		53,279		1,235 kWh	1	32 Days

Charge Details

Electric Charges		
Daily Basic Service Charge	32 days @ \$0.66000	\$21.12
Energy Charge	1,235 kWh @ \$0.09202/kWh	\$113.64
Fuel Charge	1,235 kWh @ \$0.03516/kWh	\$43.42
Storm Protection Charge	1,235 kWh @ \$0.00568/kWh	\$7.01
Clean Energy Transition Mechanism	1,235 kWh @ \$0.00418/kWh	\$5.16
Storm Surcharge	1,235 kWh @ \$0.02121/kWh	\$26.19
Florida Gross Receipt Tax		\$5.55
Electric Service Cost		\$222.09
State Tax		\$18.77
Total Electric Cost, Local Fees and Taxes		\$240.86

Avg kWh Used Per Day

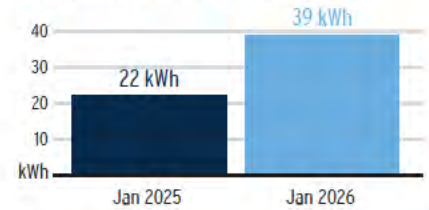

Current Month's Electric Charges \$240.86

Billing information continues on next page →



Sub-Account #: 211009338560
Statement Date: 02/02/2026

Service Address: 107 MANNS HARBOR DR, APOLLO BEACH, FL 33572-3340

Meter Read

Meter Location: Pool

Service Period: 12/23/2025 - 01/23/2026

Rate Schedule: General Service Demand - Standard

Meter Number	Read Date	Current Reading	- Previous Reading	= Total Used	Multiplier	Billing Period
1000780652	01/23/2026	83,123	39,729	43,394 kWh	1	32 Days
1000780652	01/23/2026	70.82	0	70.82 kW	1	32 Days

Charge Details

Electric Charges		
Daily Basic Service Charge	32 days @ \$1.12000	\$35.84
Billing Demand Charge	71 kW @ \$19.06000/kW	\$1,353.26
Energy Charge	43,394 kWh @ \$0.00815/kWh	\$353.66
Fuel Charge	43,394 kWh @ \$0.03516/kWh	\$1,525.73
Capacity Charge	71 kW @ \$0.72000/kW	\$51.12
Storm Protection Charge	71 kW @ \$2.02000/kW	\$143.42
Energy Conservation Charge	71 kW @ \$0.79000/kW	\$56.09
Environmental Cost Recovery	43,394 kWh @ \$0.00072/kWh	\$31.24
Clean Energy Transition Mechanism	71 kW @ \$1.15000/kW	\$81.65
Storm Surcharge	43,394 kWh @ \$0.01035/kWh	\$449.13
Florida Gross Receipt Tax		\$104.64
Electric Service Cost		\$4,185.78
State Tax		\$353.70
Total Electric Cost, Local Fees and Taxes		\$4,539.48

Current Month's Electric Charges \$4,539.48

Billing information continues on next page →

Avg kWh Used Per Day

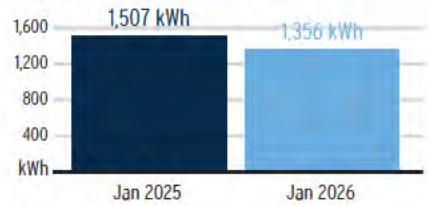

Billing Demand (kW)

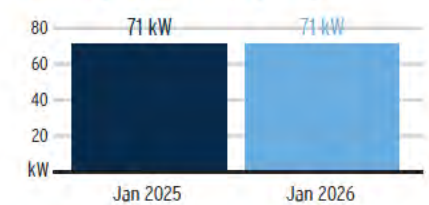

Load Factor



Decreasing the proportion of your electricity utilized at peak will improve your load factor.



Sub-Account #: 211009338982
Statement Date: 02/02/2026

Service Address: 211 IBISVIEW LN LGHT, APOLLO BEACH, FL 33572-0000

Meter Read

Service Period: 12/23/2025 - 01/23/2026

Rate Schedule: General Service - Non Demand

Meter Number	Read Date	Current Reading	-	Previous Reading	=	Total Used	Multiplier	Billing Period
1000432342	01/23/2026	355		353		2 kWh	1	32 Days

Charge Details

⚡ Electric Charges		
Daily Basic Service Charge	32 days @ \$0.66000	\$21.12
Energy Charge	2 kWh @ \$0.09202/kWh	\$0.18
Fuel Charge	2 kWh @ \$0.03516/kWh	\$0.07
Storm Protection Charge	2 kWh @ \$0.00568/kWh	\$0.01
Clean Energy Transition Mechanism	2 kWh @ \$0.00418/kWh	\$0.01
Storm Surcharge	2 kWh @ \$0.02121/kWh	\$0.04
Florida Gross Receipt Tax		\$0.55
Electric Service Cost		\$21.98
State Tax		\$1.86
Total Electric Cost, Local Fees and Taxes		\$23.84

Avg kWh Used Per Day

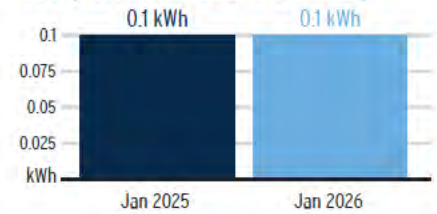

Current Month's Electric Charges \$23.84

Billing information continues on next page →



Sub-Account #: 211009339162
Statement Date: 02/02/2026

Service Address: 107 MANNS HARBOR DR, B, APOLLO BEACH, FL 33572-3340

Meter Read

Meter Location: # B

Service Period: 12/23/2025 - 01/23/2026

Rate Schedule: General Service - Non Demand

Meter Number	Read Date	Current Reading	-	Previous Reading	=	Total Used	Multiplier	Billing Period
1000967419	01/23/2026	600		521		79 kWh	1	32 Days

Charge Details

⚡ Electric Charges		
Daily Basic Service Charge	32 days @ \$0.66000	\$21.12
Energy Charge	79 kWh @ \$0.09202/kWh	\$7.27
Fuel Charge	79 kWh @ \$0.03516/kWh	\$2.78
Storm Protection Charge	79 kWh @ \$0.00568/kWh	\$0.45
Clean Energy Transition Mechanism	79 kWh @ \$0.00418/kWh	\$0.33
Storm Surcharge	79 kWh @ \$0.02121/kWh	\$1.68
Florida Gross Receipt Tax		\$0.86
Electric Service Cost		\$34.49
State Tax		\$2.91
Total Electric Cost, Local Fees and Taxes		\$37.40

Avg kWh Used Per Day

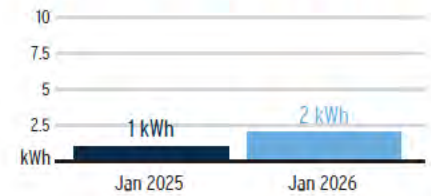

Current Month's Electric Charges \$37.40

Billing information continues on next page →



Sub-Account #: 211009420376
Statement Date: 02/02/2026

Service Address: 605 MIRABAY BLVD, APOLLO BEACH, FL 33572-3379

Meter Read

Meter Location: Pmp

Service Period: 12/23/2025 - 01/23/2026

Rate Schedule: General Service - Non Demand

Meter Number	Read Date	Current Reading	-	Previous Reading	=	Total Used	Multiplier	Billing Period
1000852706	01/23/2026	2,891		2,829		62 kWh	1	32 Days

Charge Details

Electric Charges		
Daily Basic Service Charge	32 days @ \$0.66000	\$21.12
Energy Charge	62 kWh @ \$0.09202/kWh	\$5.71
Fuel Charge	62 kWh @ \$0.03516/kWh	\$2.18
Storm Protection Charge	62 kWh @ \$0.00568/kWh	\$0.35
Clean Energy Transition Mechanism	62 kWh @ \$0.00418/kWh	\$0.26
Storm Surcharge	62 kWh @ \$0.02121/kWh	\$1.32
Florida Gross Receipt Tax		\$0.79
Electric Service Cost		\$31.73
State Tax		\$2.68
Total Electric Cost, Local Fees and Taxes		\$34.41

Avg kWh Used Per Day

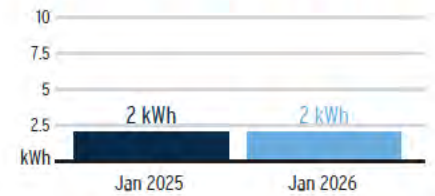

Current Month's Electric Charges \$34.41

Billing information continues on next page →



Sub-Account #: 211009420731
Statement Date: 02/02/2026

Service Address: 449 ISLEBAY DR, APOLLO BEACH, FL 33572-3332

Meter Read

Meter Location: Irr

Service Period: 12/23/2025 - 01/23/2026

Rate Schedule: General Service - Non Demand

Meter Number	Read Date	Current Reading	-	Previous Reading	=	Total Used	Multiplier	Billing Period
1000426126	01/23/2026	6,617		6,526		91 kWh	1	32 Days

Charge Details

⚡ Electric Charges		
Daily Basic Service Charge	32 days @ \$0.66000	\$21.12
Energy Charge	91 kWh @ \$0.09202/kWh	\$8.37
Fuel Charge	91 kWh @ \$0.03516/kWh	\$3.20
Storm Protection Charge	91 kWh @ \$0.00568/kWh	\$0.52
Clean Energy Transition Mechanism	91 kWh @ \$0.00418/kWh	\$0.38
Storm Surcharge	91 kWh @ \$0.02121/kWh	\$1.93
Florida Gross Receipt Tax		\$0.91
Electric Service Cost		\$36.43
State Tax		\$3.08
Total Electric Cost, Local Fees and Taxes		\$39.51

Avg kWh Used Per Day

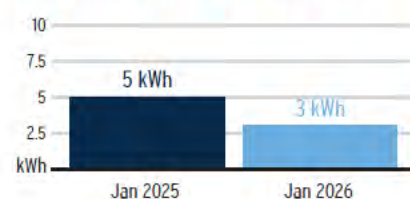

Current Month's Electric Charges \$39.51

Billing information continues on next page →



Sub-Account #: 211009420921
Statement Date: 02/02/2026

Service Address: 5633 SKIMMER DR, APOLLO BEACH, FL 33572-3353

Meter Read

Meter Location: Irr

Service Period: 12/23/2025 - 01/23/2026

Rate Schedule: General Service - Non Demand

Meter Number	Read Date	Current Reading	-	Previous Reading	=	Total Used	Multiplier	Billing Period
1000426250	01/23/2026	11,964		11,735		229 kWh	1	32 Days

Charge Details

Electric Charges		
Daily Basic Service Charge	32 days @ \$0.66000	\$21.12
Energy Charge	229 kWh @ \$0.09202/kWh	\$21.07
Fuel Charge	229 kWh @ \$0.03516/kWh	\$8.05
Storm Protection Charge	229 kWh @ \$0.00568/kWh	\$1.30
Clean Energy Transition Mechanism	229 kWh @ \$0.00418/kWh	\$0.96
Storm Surcharge	229 kWh @ \$0.02121/kWh	\$4.86
Florida Gross Receipt Tax		\$1.47
Electric Service Cost		\$58.83
State Tax		\$4.97
Total Electric Cost, Local Fees and Taxes		\$63.80

Avg kWh Used Per Day

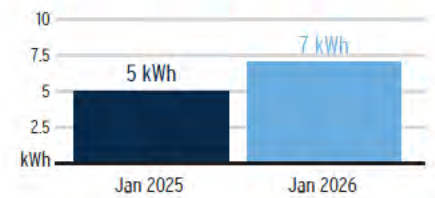

Current Month's Electric Charges \$63.80

Billing information continues on next page →



Sub-Account #: 211009421739
Statement Date: 02/02/2026

Service Address: 5424 MERRITT ISLAND DR, APOLLO BEACH, FL 33572-3375

Meter Read

Service Period: 12/23/2025 - 01/23/2026

Rate Schedule: General Service - Non Demand

Meter Number	Read Date	Current Reading	-	Previous Reading	=	Total Used	Multiplier	Billing Period
1000600632	01/23/2026	5,581		5,448		133 kWh	1	32 Days

Charge Details

⚡ Electric Charges		
Daily Basic Service Charge	32 days @ \$0.66000	\$21.12
Energy Charge	133 kWh @ \$0.09202/kWh	\$12.24
Fuel Charge	133 kWh @ \$0.03516/kWh	\$4.68
Storm Protection Charge	133 kWh @ \$0.00568/kWh	\$0.76
Clean Energy Transition Mechanism	133 kWh @ \$0.00418/kWh	\$0.56
Storm Surcharge	133 kWh @ \$0.02121/kWh	\$2.82
Florida Gross Receipt Tax		\$1.08
Electric Service Cost		\$43.26
State Tax		\$3.66
Total Electric Cost, Local Fees and Taxes		\$46.92

Avg kWh Used Per Day

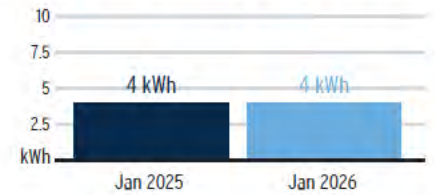

Current Month's Electric Charges \$46.92

Billing information continues on next page →



Sub-Account #: 211009421929
Statement Date: 02/02/2026

Service Address: 191 MIRABAY BLVD, APOLLO BEACH, FL 33572-3346

Meter Read

Service Period: 12/23/2025 - 01/23/2026

Rate Schedule: General Service - Non Demand

Meter Number	Read Date	Current Reading	Previous Reading	=	Total Used	Multiplier	Billing Period
1000769622	01/23/2026	47,587	46,107		1,480 kWh	1	32 Days

Charge Details

⚡ Electric Charges		
Daily Basic Service Charge	32 days @ \$0.66000	\$21.12
Energy Charge	1,480 kWh @ \$0.09202/kWh	\$136.19
Fuel Charge	1,480 kWh @ \$0.03516/kWh	\$52.04
Storm Protection Charge	1,480 kWh @ \$0.00568/kWh	\$8.41
Clean Energy Transition Mechanism	1,480 kWh @ \$0.00418/kWh	\$6.19
Storm Surcharge	1,480 kWh @ \$0.02121/kWh	\$31.39
Florida Gross Receipt Tax		\$6.55
Electric Service Cost		\$261.89
State Tax		\$22.13
Total Electric Cost, Local Fees and Taxes		\$284.02

Avg kWh Used Per Day

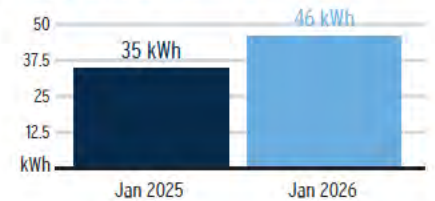

Current Month's Electric Charges \$284.02

Billing information continues on next page →



Sub-Account #: 211009422786
Statement Date: 02/02/2026

Service Address: 5423 TYBEE ISLAND DR, APOLLO BEACH, FL 33572-3307

Meter Read

Meter Location: GATE

Service Period: 12/23/2025 - 01/23/2026

Rate Schedule: General Service - Non Demand

Meter Number	Read Date	Current Reading	-	Previous Reading	=	Total Used	Multiplier	Billing Period
1000580302	01/23/2026	4,389		4,314		75 kWh	1	32 Days

Charge Details

Electric Charges		
Daily Basic Service Charge	32 days @ \$0.66000	\$21.12
Energy Charge	75 kWh @ \$0.09202/kWh	\$6.90
Fuel Charge	75 kWh @ \$0.03516/kWh	\$2.64
Storm Protection Charge	75 kWh @ \$0.00568/kWh	\$0.43
Clean Energy Transition Mechanism	75 kWh @ \$0.00418/kWh	\$0.31
Storm Surcharge	75 kWh @ \$0.02121/kWh	\$1.59
Florida Gross Receipt Tax		\$0.85
Electric Service Cost		\$33.84
State Tax		\$2.86
Total Electric Cost, Local Fees and Taxes		\$36.70

Avg kWh Used Per Day

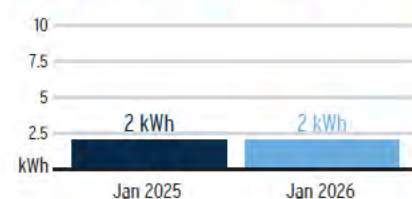

Current Month's Electric Charges \$36.70

Billing information continues on next page →



Sub-Account #: 211009423289
Statement Date: 02/02/2026

Service Address: 804 ISLEBAY DR, APOLLO BEACH, FL 33572-3380

Meter Read

Service Period: 12/23/2025 - 01/23/2026

Rate Schedule: General Service - Non Demand

Meter Number	Read Date	Current Reading	-	Previous Reading	=	Total Used	Multiplier	Billing Period
1000430259	01/23/2026	3,883		3,827		56 kWh	1	32 Days

Charge Details

⚡ Electric Charges		
Daily Basic Service Charge	32 days @ \$0.66000	\$21.12
Energy Charge	56 kWh @ \$0.09202/kWh	\$5.15
Fuel Charge	56 kWh @ \$0.03516/kWh	\$1.97
Storm Protection Charge	56 kWh @ \$0.00568/kWh	\$0.32
Clean Energy Transition Mechanism	56 kWh @ \$0.00418/kWh	\$0.23
Storm Surcharge	56 kWh @ \$0.02121/kWh	\$1.19
Florida Gross Receipt Tax		\$0.77
Electric Service Cost		\$30.75
State Tax		\$2.60
Total Electric Cost, Local Fees and Taxes		\$33.35

Avg kWh Used Per Day

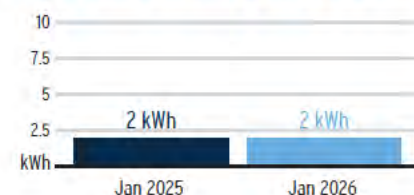

Current Month's Electric Charges \$33.35

Billing information continues on next page →



Sub-Account #: 211009423438
Statement Date: 02/02/2026

Service Address: 564 MANNS HARBOR DR, APOLLO BEACH, FL 33572-3330

Meter Read

Service Period: 12/23/2025 - 01/23/2026

Rate Schedule: General Service - Non Demand

Meter Number	Read Date	Current Reading	Previous Reading	=	Total Used	Multiplier	Billing Period
1000428233	01/23/2026	30,436	29,885		551 kWh	1	32 Days

Charge Details

Electric Charges		
Daily Basic Service Charge	32 days @ \$0.66000	\$21.12
Energy Charge	551 kWh @ \$0.09202/kWh	\$50.70
Fuel Charge	551 kWh @ \$0.03516/kWh	\$19.37
Storm Protection Charge	551 kWh @ \$0.00568/kWh	\$3.13
Clean Energy Transition Mechanism	551 kWh @ \$0.00418/kWh	\$2.30
Storm Surcharge	551 kWh @ \$0.02121/kWh	\$11.69
Florida Gross Receipt Tax		\$2.78
Electric Service Cost		\$111.09
State Tax		\$9.39
Total Electric Cost, Local Fees and Taxes		\$120.48

Avg kWh Used Per Day

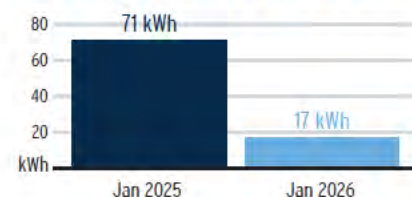

Current Month's Electric Charges \$120.48

Total Current Month's Charges \$10,546.34



102 BRE

7534 0100 NO RP 01 02012024 YNNNNNNN 0007193 SJ T37

FEB - 9 2021

10053 1 AB 0.636

HARBOR BAY CDD
C/O RIZZETTA & COMPANY
3434 COLWELL AVE STE 200
TAMPA FL 33614-8390



ACCOUNT INVOICE

My Customer Number: 1744290

Please Pay By: Upon Receipt

Total Due: \$781.49

PAY ONLINE
TerminixCommercial.com

PAY BY PHONE
1.855.456.3631

QUESTIONS
• 1.800.TERMINIX
• TerminixCommercial.com

! YOUR ACCOUNT IS PAST DUE.

If you're having trouble paying your bill, we can work with you. Just call 1.800.TERMINIX to speak with a billing representative. You can also pay your bill online or by mail.



SERVICE DATE	DESCRIPTION OF SERVICES & SERVICE ADDRESS	INVOICE NUMBER	CHARGES	PAYMENTS / CREDITS	NET AMOUNT
12/12/2025	Pest Control Work Order 21436573633 Environmental and Safety Surcharge	467454721	\$80.56 \$5.00		\$85.56
	Location: 107 MANNS HARBOUR DR, APOLLO BEACH FL 33572				
12/12/2025	Pest Control Work Order 21408244108 Environmental and Safety Surcharge		\$71.45 \$5.00		\$76.45
	Location: 107 MANNS HARBOUR DR, APOLLO BEACH FL 33572				
	Pest Control		\$92.00		
DUE DATE: Upon Receipt			TOTAL DUE: \$781.49		

The environmental and safety surcharge covers ongoing costs required for maintaining environmental and safety initiatives for our employees and customers. This includes but is not limited to transportation improvements, safety training and service safety protocols as they may pertain to each industry we service. Limitations apply.

Please tear along line to remit.

\$ Payment Options:

- EasyPay automated payments (sign up at TerminixCommercial.com)
- Pay online at My Account at TerminixCommercial.com
- Pay by phone at 1.855.456.3631
- Pay by enclosed check
- Credit card payment. Please fill out the following:

Circle One: DISCOVER VISA MasterCard American Express
(_____) Exp date: ____ / ____

Name (as it appears on credit card): _____

Authorized Signature: _____

Amount Due: **\$781.49**

Amount Paid: _____

Invoice Number: 467454721

Customer Number: 1744290

HARBOR BAY CDD
C/O RIZZETTA & COMPANY
3434 COLWELL AVE STE 200
TAMPA FL 33614

Sign up for EasyPay
automated payments at
TerminixCommercial.com

REMIT TO:

TERMINIX PROCESSING CENTER
PO BOX 802155
CHICAGO IL 60680-0

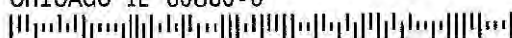

3 00000000 10 000017442901 00000000004674547213 0007814900078149 6



ACCOUNT INVOICE

My Customer Number: 1744290

Please Pay By: Upon Receipt

Total Due: \$781.49

SERVICE DATE	DESCRIPTION OF SERVICES & SERVICE ADDRESS	INVOICE NUMBER	CHARGES	PAYMENTS / CREDITS	NET AMOUNT
12/12/2025	Work Order 21436484620 Environmental and Safety Surcharge		\$5.00		
	Location: 107 MANNS HARBOUR DR, APOLLO BEACH FL 33572				\$97.00
12/12/2025	Pest Control Work Order 21436495206 Environmental and Safety Surcharge		\$80.56 \$5.00		
	Location: 5248 ADMIRAL POINTE DR, APOLLO BEACH FL 33572				\$85.56
12/12/2025	Pest Control Work Order 21377027050 Environmental and Safety Surcharge		\$211.46 \$7.00		
	Location: 107 MANNS HARBOUR DR, APOLLO BEACH FL 33572				\$218.46
12/23/2025	Pest Control Work Order 21408466868 Environmental and Safety Surcharge		\$211.46 \$7.00		
	Location: 107 MANNS HARBOUR DR, APOLLO BEACH FL 33572				\$218.46
DUE DATE: Upon Receipt			TOTAL DUE: \$781.49		

The environmental and safety surcharge covers ongoing costs required for maintaining environmental and safety initiatives for our employees and customers. This includes but is not limited to transportation improvements, safety training and service safety protocols as they may pertain to each industry we service. Limitations apply.





7534 0100 NO RP 01 02012026 YNNNNNNN 0007188 S1 T37

10048 1 AB 0.636

HARBOR BAY CDD
C/O RIZZETTA & COMPANY
3434 COLWELL AVE STE 200
TAMPA FL 33614-8390

FEB - 9 2026



ACCOUNT INVOICE	
My Customer Number:	1744290
Please Pay By:	02/15/2026
Total Due:	\$781.49

- PAY ONLINE**
TerminixCommercial.com
- PAY BY PHONE**
1.855.456.3631
- QUESTIONS**
• 1.800.TERMINIX
• TerminixCommercial.com

EASY WAYS TO PAY YOUR TERMINIX® INVOICE

Paying your bill is easy, especially online. Just visit the "Manage My Account" portal at TerminixCommercial.com and sign up with your **Customer Number: 1744290** and phone number to start paying bills online.



SERVICE DATE	DESCRIPTION OF SERVICES & SERVICE ADDRESS	INVOICE NUMBER	CHARGES	PAYMENTS / CREDITS	NET AMOUNT
01/09/2026	Pest Control Work Order 21523825846 Environmental and Safety Surcharge	468447476	\$80.56 \$5.00		\$85.56
	Location: 107 MANN'S HARBOUR DR, APOLLO BEACH FL 33572				
01/09/2026	Pest Control Work Order 21524849465 Environmental and Safety Surcharge		\$92.00 \$5.00		\$97.00
	Location: 107 MANN'S HARBOUR DR, APOLLO BEACH FL 33572				
01/09/2026	Pest Control Work Order 21524819530		\$80.56		
DUE DATE: 02/15/2026			TOTAL DUE: \$781.49		
<small>This invoice reflects payments received by 02/01/2026. If you have not paid your previous balance, please make your payment today. The environmental and safety surcharge covers ongoing costs required for maintaining environmental and safety initiatives for our employees and customers. This includes but is not limited to transportation improvements, safety training and service safety protocols as they may pertain to each industry we service. Limitations apply.</small>					

Please tear along line to remit.

- \$ Payment Options:**
- EasyPay automated payments (sign up at TerminixCommercial.com)
 - Pay online at My Account at TerminixCommercial.com
 - Pay by phone at 1.855.456.3631
 - Pay by enclosed check
 - Credit card payment. Please fill out the following:

Circle One: DISCOVER VISA MasterCard American Express
(_____) Exp date: ____ / ____

Name (as it appears on credit card): _____
Authorized Signature: _____
Amount Due: **\$781.49**
Amount Paid: _____

Invoice Number: 468447476
Customer Number: 1744290

HARBOR BAY CDD
C/O RIZZETTA & COMPANY
3434 COLWELL AVE STE 200
TAMPA FL 33614

Sign up for EasyPay
automated payments at
TerminixCommercial.com

REMIT TO:
TERMINIX PROCESSING CENTER
PO BOX 802155
CHICAGO IL 60680-0



ACCOUNT INVOICE

My Customer Number:	1744290
Please Pay By:	02/15/2026
Total Due:	\$781.49

SERVICE DATE	DESCRIPTION OF SERVICES & SERVICE ADDRESS	INVOICE NUMBER	CHARGES	PAYMENTS / CREDITS	NET AMOUNT
	Environmental and Safety Surcharge		\$5.00		
	Location: 5248 ADMIRAL POINTE DR, APOLLO BEACH FL 33572				\$85.56
01/09/2026	Pest Control Work Order 21467916730		\$71.45		
	Environmental and Safety Surcharge		\$5.00		
	Location: 107 MANNS HARBOUR DR, APOLLO BEACH FL 33572				\$76.45
01/09/2026	Pest Control Work Order 21436943703		\$211.46		
	Environmental and Safety Surcharge		\$7.00		
	Location: 107 MANNS HARBOUR DR, APOLLO BEACH FL 33572				\$218.46
01/27/2026	Pest Control Work Order 21468475541		\$211.46		
	Environmental and Safety Surcharge		\$7.00		
	Location: 107 MANNS HARBOUR DR, APOLLO BEACH FL 33572				\$218.46
DUE DATE: 02/15/2026			TOTAL DUE: \$781.49		



This invoice reflects payments received by 02/01/2026. If you have not paid your previous balance, please make your payment today.
The environmental and safety surcharge covers ongoing costs required for maintaining environmental and safety initiatives for our employees and customers. This includes but is not limited to transportation improvements, safety training and service safety protocols as they may pertain to each industry we service. Limitations apply.

HARBOR BAY COMMUNITY DEVELOPMENT DISTRICT

District Office – Wesley Chapel, Florida (813) 994-1001
Mailing Address – 3434 Colwell Avenue Suite 200, Tampa, Florida 33614
www.harborbaycdd.org

Check Request

Amount: \$79.00

Date: 01/31/26

Payable to: Timothy Nargi

Address: 5632 Skimmer Drive
Apollo Beach, FL 33572

Description: Reimbursement for Ethics Course 12/25

Requestor: Venessa Smith

Receipt Number: 1491143
Customer: NARGI, TIMOTHY
eMarket Payments
Date: 12/30/2025

Description	Amount
4-Hour Ethics Course for Special Districts 2025 Membership status: Non-Member Fee TIMOTHY NARGI HBCDD 4-Hour Ethics Course for Special Districts 2025 https://elearning.iog.fsu.edu/enroll/3196788? price_id=4082495	\$79.00
Total	\$79.00

Payments Received	Amount
FSU eMarket Credit Card American Express XXXXXXXXXXXX5004 Authorization # 260833	\$79.00
Total	\$79.00



Date- 02-05-26

GL Code- 572004833

Approved by- [Signature]

INVOICE

Aqua Triangle 1 Corp
12801 Belcher Rd S
Largo, FL 33773
(727) 531-0473
billing@triangle-pool.com

BILL TO:

HARBOR BAY COMMUNITY
DEVELOPMENT DISTRICT
(MIRABAY CLUB)
C/O RIZZETTA & COMPANY
3434 COLWELL AVENUE,
SUITE 200
TAMPA, FLORIDA 33614

SHIP TO:

HARBOR BAY COMMUNITY
DEVELOPMENT DISTRICT
(MIRABAY CLUB)
107 MANNS HARBOR DRIVE
APOLLO BEACH, FLORIDA
33572

Invoice No: **011544-82**
Status: **Open**
Invoice Date: **2/05/2026**
Due Date: **3/07/2026**
Total: **\$452.50**

Service Date	Product/Service	Quantity	Unit Price	Total
2/04/2026	6800 6800 GALLONS LIQUID CHLORINE	181.00	\$2.50	\$452.50

Please Note: If any invoiced amount is not received by the mentioned due date, then those charges may accrue a late fee of \$5.00 of the outstanding balance every 30 days, or the maximum rate permitted by the law, whichever is lower.

Subtotal:	\$452.50
Tax:	\$0.00
Invoice Amount:	\$452.50
Previous Payment(s):	\$0.00
Amount Due (USD)	\$452.50

Thank you for doing business with us!



Date- 02-05-26

GL Code- 573004833

Approved by- [Signature]

INVOICE

Aqua Triangle 1 Corp
12801 Belcher Rd S
Largo, FL 33773
(727) 531-0473
billing@triangle-pool.com

BILL TO:

HARBOR BAY COMMUNITY
DEVELOPMENT DISTRICT
(MIRABAY CLUB)
C/O RIZZETTA & COMPANY
3434 COLWELL AVENUE,
SUITE 200
TAMPA, FLORIDA 33614

SHIP TO:

HARBOR BAY COMMUNITY
DEVELOPMENT DISTRICT
(MIRABAY CLUB)
107 MANNS HARBOR DRIVE
APOLLO BEACH, FLORIDA
33572

Invoice No: **011544-84**
Status: **Open**
Invoice Date: **2/05/2026**
Due Date: **3/07/2026**
Total: **\$355.00**

Service Date	Product/Service	Quantity	Unit Price	Total
	ADMIRAL POINT			
	6800 6800 GALLONS LIQUID CHLORINE	97.00	\$2.50	\$242.50
	15 GAL DRUM - SULFURIC ACID 15 GAL DRUM - SULFURIC ACID	1.00	\$112.50	\$112.50

Please Note: If any invoiced amount is not received by the mentioned due date, then those charges may accrue a late fee of \$5.00 of the outstanding balance every 30 days, or the maximum rate permitted by the law, whichever is lower.

Subtotal:	\$355.00
Tax:	\$0.00
Invoice Amount:	\$355.00
Previous Payment(s):	\$0.00
Amount Due (USD)	\$355.00

Thank you for doing business with us!



INVOICE

Aqua Triangle 1 Corp

12801 Belcher Rd S

Largo, FL 33773

(727) 531-0473

billing@triangle-pool.com

BILL TO:

HARBOR BAY COMMUNITY
DEVELOPMENT DISTRICT
(MIRABAY CLUB)
C/O RIZZETTA & COMPANY
3434 COLWELL AVENUE,
SUITE 200
TAMPA, FLORIDA 33614

SHIP TO:

HARBOR BAY COMMUNITY
DEVELOPMENT DISTRICT
(MIRABAY CLUB)
107 MANNS HARBOR DRIVE
APOLLO BEACH, FLORIDA
33572

Invoice No: **321834**
Status: **Open**
Invoice Date: **1/22/2026**
Due Date: **2/21/2026**
Total: **\$360.22**

Service Date	Product/Service	Quantity	Unit Price	Total
1/21/2026	15 GAL DRUM - SULFURIC ACID 15 GAL DRUM - SULFURIC ACID	1.00	\$157.72	\$157.72
	6800 6800 GALLONS LIQUID CHLORINE	81.00	\$2.50	\$202.50

Please Note: If any invoiced amount is not received by the mentioned due date, then those charges may accrue a late fee of \$5.00 of the outstanding balance every 30 days, or the maximum rate permitted by the law, whichever is lower.

Subtotal:	\$360.22
Tax:	\$0.00
Invoice Amount:	\$360.22
Previous Payment(s):	\$0.00
Amount Due (USD)	\$360.22

Date- 02-03-2026

GL Code- 57200 4833

Approved by- [Signature]

Thank you for doing business with us!



Date- 02-20-26

GL Code- 572004833

Approved by- [Signature]

INVOICE

Aqua Triangle 1 Corp
12801 Belcher Rd S
Largo, FL 33773
(727) 531-0473
billing@triangle-pool.com

BILL TO:

HARBOR BAY COMMUNITY
DEVELOPMENT DISTRICT
(MIRABAY CLUB)
C/O RIZZETTA & COMPANY
3434 COLWELL AVENUE,
SUITE 200
TAMPA, FLORIDA 33614

SHIP TO:

HARBOR BAY COMMUNITY
DEVELOPMENT DISTRICT
(MIRABAY CLUB)
107 MANNS HARBOR DRIVE
APOLLO BEACH, FLORIDA
33572

Invoice No: **357655**
Status: **Open**
Invoice Date: **2/12/2026**
Due Date: **3/14/2026**
Total: **\$270.00**

Service Date	Product/Service	Quantity	Unit Price	Total
--------------	-----------------	----------	------------	-------

2/11/2026	6800 6800 GALLONS LIQUID CHLORINE	108.00	\$2.50	\$270.00
-----------	---	--------	--------	----------

Please Note: If any invoiced amount is not received by the mentioned due date, then those charges may accrue a late fee of \$5.00 of the outstanding balance every 30 days, or the maximum rate permitted by the law, whichever is lower.

Subtotal:	\$270.00
Tax:	\$0.00
Invoice Amount:	\$270.00
Previous Payment(s):	\$0.00
Amount Due (USD)	\$270.00

Thank you for doing business with us!



Date- 02-20-26

GL Code- 572004833

Approved by- [Signature]

INVOICE

Aqua Triangle 1 Corp
12801 Belcher Rd S
Largo, FL 33773
(727) 531-0473
billing@triangle-pool.com

BILL TO:

HARBOR BAY COMMUNITY
DEVELOPMENT DISTRICT
(MIRABAY CLUB)
C/O RIZZETTA & COMPANY
3434 COLWELL AVENUE,
SUITE 200
TAMPA, FLORIDA 33614

SHIP TO:

HARBOR BAY COMMUNITY
DEVELOPMENT DISTRICT
(MIRABAY CLUB)
107 MANNS HARBOR DRIVE
APOLLO BEACH, FLORIDA
33572

Invoice No: **8529868157**
Status: **Open**
Invoice Date: **2/19/2026**
Due Date: **3/21/2026**
Total: **\$737.50**

Service Date	Product/Service	Quantity	Unit Price	Total
2/18/2026	6800 6800 GALLONS LIQUID CHLORINE	205.00	\$2.50	\$512.50
	15 GAL DRUM - SULFURIC ACID 15 GAL DRUM - SULFURIC ACID	2.00	\$112.50	\$225.00

Please Note: If any invoiced amount is not received by the mentioned due date, then those charges may accrue a late fee of \$5.00 of the outstanding balance every 30 days, or the maximum rate permitted by the law, whichever is lower.

Subtotal: \$737.50
Tax: \$0.00
Invoice Amount: \$737.50
Previous Payment(s): \$0.00
Amount Due (USD) **\$737.50**

Thank you for doing business with us!

INVOICE



USA Services of Florida, LLC
4141 Rockside Road, Suite 100
Seven Hills OH 44131
United States

SERVICES PERFORMED BY:
USA Services of Florida, LLC

BILL TO:
Harbor Bay Community Development
District
c/o Rizzetta & Company
3434 Colwell Avenue, Suite 200
Tampa FL 33614
United States

INVOICE DATE: 1/22/2026
SALES ORDER #: SO3348
INVOICE #: FL12284080
TERMS: NET 30
DUE DATE: 2/21/2026
CUSTOMER PO:
SERVICE PERIOD: JAN 2026
MEMO: MIRA BAY

ITEM	DESCRIPTION	SERVICE DATE	QTY	RATE	AMOUNT
HARBOR BAY CDD	Broom Sweeping: Mira Bay	1/19/2026	1	\$900.00000	\$900.00
	CY = 8		1	\$0.00	\$153.09
FS: VEC Charges	VEC Charges		1	\$0.00	\$47.39
FS: EHSC Charges	EHSC Charges				
SUBTOTAL					\$1,100.48
TAX TOTAL					\$0.00
TOTAL					\$1,100.48
AMOUNT PAID					\$0.00
AMOUNT DUE					\$1,100.48

We are delighted to have you as a customer and appreciate your business!
For Invoice questions, please email billing@sweepingcorp.com
Please be sure to include invoice numbers / remittance with your check payment.
If paying by ACH, please send remittance advice to remits@sweepingcorp.com
For ease of payment, use the "Click Here to Pay Now" link below to pay by Credit Card or ACH

SUBTOTAL \$1,100.48
TAX TOTAL \$0.00
TOTAL \$1,100.48
AMOUNT PAID \$0.00
AMOUNT DUE \$1,100.48

[Click Here to Pay Now](#)

Date- 02-03-26

GL Code- 541005155

Approved by- [Signature]

Please remit electronic bank payments to:
USA Services of Florida, LLC
ABA/Routing #: 041001039
Account #: 359681555850

Remittance Slip

Make Check Payable To:
USA Services of Florida, LLC
Payment Remittance
P.O. Box 74042
Cleveland OH 44194-0124
United States

Customer Name:	HARBOR BAY CDD
Invoice #:	FL12284080
Amount Due:	\$1,100.48
Amount Paid:	

[Click Here to Pay Now](#)



USA Services of Florida, LLC
 4141 Rockside Road, Suite 100
 Seven Hills OH 44131
 United States

SERVICES PERFORMED BY:
 USA Services of Florida, LLC

BILL TO:
 Harbor Bay Community Development
 District
 c/o Rizzetta & Company
 3434 Colwell Avenue, Suite 200
 Tampa FL 33614
 United States

INVOICE

Date- 02-20-26

GL Code- 541005155

Approved by- 

INVOICE DATE: 2/10/2026

SALES ORDER #: SO3348

INVOICE #: FL12284461

TERMS: NET 30

DUE DATE: 3/12/2026

CUSTOMER PO:

SERVICE PERIOD: FEB 2026

MEMO: MIRA BAY

ITEM	DESCRIPTION	SERVICE DATE	QTY	RATE	AMOUNT
HARBOR BAY CDD	Broom Sweeping: Mira Bay CY = 4	2/2/2026	1	\$900.00000	\$900.00
FS: VEC Charges	VEC Charges		1	\$0.00	\$132.21
FS: EHSC Charges	EHSC Charges		1	\$0.00	\$46.45
SUBTOTAL					\$1,078.66
TAX TOTAL					\$0.00
TOTAL					\$1,078.66
AMOUNT PAID					\$0.00
AMOUNT DUE					\$1,078.66

We are delighted to have you as a customer and appreciate your business!
 For Invoice questions, please email billing@sweepingcorp.com
 Please be sure to include invoice numbers / remittance with your check payment.
 If paying by ACH, please send remittance advice to remits@sweepingcorp.com
 For ease of payment, use the "Click Here to Pay Now" link below to pay by Credit Card or ACH

SUBTOTAL	\$1,078.66
TAX TOTAL	\$0.00
TOTAL	\$1,078.66
AMOUNT PAID	\$0.00
AMOUNT DUE	\$1,078.66

[Click Here to Pay Now](#)

Please remit electronic bank payments to:

USA Services of Florida, LLC
 ABA/Routing #: 041001039
 Account #: 359681555850

Remittance Slip

Make Check Payable To:
 USA Services of Florida, LLC
 Payment Remittance
 P.O. Box 74042
 Cleveland OH 44194-0124
 United States

Customer Name:	HARBOR BAY CDD
Invoice #:	FL12284461
Amount Due:	\$1,078.66
Amount Paid:	

[Click Here to Pay Now](#)



Customer Care

Invoice Summary

Harbor Bay Community Development District C/O Rizzetta & Company 3434 Colwell Avenue Suite 200 Tampa, FL 33614

Hours of Operation M-F, 7am - 6pm CT Telephone 877-222-5617

Contract Number 450-0078530-000 Customer Number 1055731246 Invoice Number 5037509498 Due Date 02/27/2026 Invoice Date 01/30/2026 Total Due \$53.92

Payments Wells Fargo Vendor Financial Services, LLC PO Box 105743 Atlanta, GA 30348-5743

Email wfef@wellsfargo.com

Online Services Website: https://www.myaccounts.wellsfargo.com Privacy: https://wellsfargo.com/privacy-security

Last Payment \$125.15 posted on 01/09/2026

Important Messages

Your contract/s are on email billing. Please contact Customer Care at the number listed on this invoice to update or add additional email addresses.

Make the Switch to recurring ACH Payments — It's Fast, Secure, Effortless, and FREE!

Why risk possible delays with mailing a check? Electronic payments save you time, reduce errors, and offer peace of mind with secure processing. Plus, you'll help reduce environmental waste and streamline your financial management. You can head to the online section of your invoice above to get everything set up.

Join the smarter way to pay — go electronic today!

Table with 4 columns: Contract Number, Asset Description, Model/Serial Number, Asset Location. Includes a summary table with columns: Item Description, Original Invoice, Amount, Tax, Item Total, Due Date, Subtotal.

Detach and return the bottom remittance portion with your payment. Include invoice number on check.

Customer Care 801 Walnut Street MAC: F0006-053 Des Moines, IA 50309

Contract Number 450-0078530-000 Due Date 02/27/2026 Invoice Number 5037509498 Invoice Date 01/30/2026 Current Due \$53.92 Total Due \$53.92

Date- 02-03-26

GL Code- 572005101

Approved by- [Signature] Amount Enclosed \$

Please make check payable to:

Wells Fargo Vendor Financial Services, LLC PO Box 105743 Atlanta, GA 30348-5743

Harbor Bay Community Development District C/O Rizzetta & Company 3434 Colwell Avenue Suite 200 Tampa, FL 33614

00000503750949845090000000539220260227000000053927

**MIRA BAY
COMMUNITY DEVELOPMENT DISTRICT**

DISTRICT OFFICE · WESLEY CHAPEL, FLORIDA (239) 936-0913
MAILING ADDRESS · 3434 COLWELL AVENUE, SUITE 200 · TAMPA, FLORIDA 33614

**Operation and Maintenance Expenditures
February 2026
For Board Approval**

Attached please find the check register listing the Operation and Maintenance expenditures paid from February 1, 2026 through February 28, 2026. This does not include expenditures previously approved by the Board.

The total items being presented: **\$18,812.57**

Approval of Expenditures:

_____ Chairperson

_____ Vice Chairperson

_____ Assistant Secretary

Mira Bay Community Development District

Paid Operation & Maintenance Expenditures

February 1, 2026 Through February 28, 2026

<u>Vendor Name</u>	<u>Check Number</u>	<u>Invoice Number</u>	<u>Invoice Description</u>	<u>Invoice Amount</u>
AlSCO, Inc.	200126	LTAM1114900	Supplies 02/25	\$ 108.00
AlSCO, Inc.	200130	LTAM1115818	Supplies 02/26	\$ 129.78
AlSCO, Inc.	300260	LTAM1116707	Supplies 02/26	\$ 108.00
Aroma Coffee Service Inc.	200127	0223189800	Coffee 01/26	\$ 79.95
Aroma Coffee Service Inc.	200123	0223191720	Coffee 01/26	\$ 994.68
Aroma Coffee Service Inc.	200131	0223193300	Coffee Supplies 02/26	\$ 1,121.29
Aroma Coffee Service Inc.	200136	0223194460	Supplies 02/26	\$ 887.80
Chastity Kelly	200129	021026 Kelly	Reimbursement - Band	\$ 900.00
Cheney Brothers, Inc.	20260213-1	06-910012119	Food 02/26	\$ 107.70
Cheney Brothers, Inc.	20260213-1	06-910013226	Food 02/26	\$ 64.21
Cheney Brothers, Inc.	20260213-1	06-910013420	Food 02/26	\$ 737.24
Cheney Brothers, Inc.	20260220-2	06-910058187	Food & Supplies 02/26	\$ 1,188.65

Mira Bay Community Development District

Paid Operation & Maintenance Expenditures

February 1, 2026 Through February 28, 2026

<u>Vendor Name</u>	<u>Check Number</u>	<u>Invoice Number</u>	<u>Invoice Description</u>	<u>Invoice Amount</u>
AlSCO, Inc.	200126	LTAM1114900	Supplies 02/25	\$ 108.00
AlSCO, Inc.	200130	LTAM1115818	Supplies 02/26	\$ 129.78
Cheney Brothers, Inc.	20260227-1	06-910101845	Food & Supplies 02/26	\$ 1,907.57
Cheney Brothers, Inc.	20260227-1	06-910109247	Food 02/26	\$ 259.47
Cheney Brothers, Inc.	20260213-1	06-929954533	Food 01/26	\$ 103.97
Cheney Brothers, Inc.	20260213-1	06-929970007	Food 01/26	\$ 552.05
Cheney Brothers, Inc.	20260213-1	06-929970016	Food 01/26	\$ 124.49
Cheney Brothers, Inc.	20260213-1	06-929970426	Food 01/26	\$ 72.98
Cintas Corporation	200128	1905120137	Supplies 01/26	\$ 320.00
Cintas Corporation	20260218-1	1906049016	Supplies 12/25	\$ 320.00
Cintas Corporation	20260218-1	1906080693	Supplies 01/26	\$ 320.00
Cintas Corporation	20260218-1	4254382338	Supplies 12/25	\$ 1,183.67
Cintas Corporation	20260218-1	4256455380	Supplies 01/26	\$ 1,212.25
Cintas Corporation	200124	4257978117	Supplies 01/26	\$ 1,145.41

Mira Bay Community Development District

Paid Operation & Maintenance Expenditures

February 1, 2026 Through February 28, 2026

<u>Vendor Name</u>	<u>Check Number</u>	<u>Invoice Number</u>	<u>Invoice Description</u>	<u>Invoice Amount</u>
AlSCO, Inc.	200126	LTAM1114900	Supplies 02/25	\$ 108.00
AlSCO, Inc.	200130	LTAM1115818	Supplies 02/26	\$ 129.78
Cintas Corporation	200132	4258726188	Supplies 02/26	\$ 1,145.41
Cintas Corporation	200135	4259493913	Supplies 02/26	\$ 1,212.25
Coca-Cola Beverages Florida, LLC	200125	50775647013	Beverage 01/26	\$ 139.24
David Nichols	200134	2	Performance 02/26	\$ 500.00
DeConna Ice Cream Company, Inc	200137	INV00418486	Ice Cream 01/26	\$ 675.60
DeConna Ice Cream Company, Inc	200137	INV00425054	Ice Cream 02/26	\$ 201.60
Facilities Management Express	200138	40085	Monthly Subscription 02/26	\$ 465.76
Pepin	200133	4268497	Beer 02/26	\$ 356.29
Southern Glazer's Wine and Spirits	20260223-1	4944791	Liquor 02/26	\$ <u>583.98</u>
Report Total				\$ <u>19,229.29</u>



AlSCO
507 North Willow Avenue
Tampa, FL 33606

Phone : (813) 253-0431
Fax : (813) 251-2650

INVOICE

LTAM1114900

Invoice Date: Feb 04 2026
Customer No: 369181
Location No: 369181
Route: 24 Stop: 170
Terms: Net 10 EOM
Purchase Order:

Invoice For

Mirabay Club
107 Manns Harbor Dr
Apollo Beach, FL 33572-3340

Delivery To

Harbor Bay Mirabay Club
107 Manns Harbor Dr
Apollo Beach, FL 33572-3340

Phone : 813-649-1500 ext

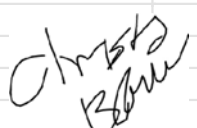
Quantity	Item Code	Item Description	Wearer	Wearer Name	Invty	Item Value
2	9650	Laundry Bag Stand			2	0.00
	5505-GN	Laundry Bag, Green			20	0.00
2	2405	3x10 Mirabay Club			4	27.00
4	2405	4x6 Mirabay Club			8	54.00
	9925	Special Delivery Charge				0.00
	SVCCHG%	Service Charge				27.00
<p>****SPECIAL ****</p> <p>Gloves starting at \$25 per case of 1000</p> <p>Can liners starting at \$18.90 per case of 1000</p> <p>Need gloves or can liners, ask your RSR or call 813-253-0431 to place an order.</p>						
<p>**Want to add a credit card to your account for payment. Go to the website below and click register for A-Track to view invoices, statements and add payment methods.**</p> <p>https://atrack.alsco.com/Account/Login</p>						
						 CHRISTY B Feb 04 2026, 8:16 AM 27.7486,-82.4176

The services for which these charges are made are being furnished to you pursuant to a service agreement between our company as supplier and the above named customer. Said merchandise is not to be cleaned or laundered other than by our company. Customers are responsible for articles lost or damaged.	Sub Total	\$108.00
	Tax EXEMPT	\$0.00
	Invoice Total	\$108.00



AlSCO
507 North Willow Avenue
Tampa, FL 33606

Phone : (813) 253-0431
Fax : (813) 251-2650

INVOICE

LTAM1115818

Invoice Date: Feb 11 2026
Customer No: 369181
Location No: 369181
Route: 24 Stop: 170
Terms: Net 10 EOM
Purchase Order:

Invoice For

Mirabay Club
107 Manns Harbor Dr
Apollo Beach, FL 33572-3340

Delivery To

Harbor Bay Mirabay Club
107 Manns Harbor Dr
Apollo Beach, FL 33572-3340

Phone : 813-649-1500 ext

Quantity	Item Code	Item Description	Wearer	Wearer Name	Invty	Item Value
10	60118-WH	85X85 Tablecloth, White				20.30
2	9650	Laundry Bag Stand			2	0.00
	5505-GN	Laundry Bag, Green			20	0.00
2	2405	3x10 Mirabay Club			4	27.00
4	2405	4x6 Mirabay Club			8	54.00
	9925	Special Delivery Charge				0.00
	SVCCHG%	Service Charge				27.00
		Finance Charge - Dec 2025 PD \$98.80				1.48

******SPECIAL******

Gloves starting at \$25 per case of 1000
Can liners starting at \$18.90 per case of 1000
Need gloves or can liners, ask your RSR or call 813-253-0431 to place an order.

Want to add a credit card to your account for payment. Go to the website below and click register for A-Track to view invoices, statements and add payment methods.
<https://atrack.alsco.com/Account/Login>

Christy C
CO

CHRISTY C Feb 11 2026, 8:23 AM 27.7486, -82.4176

The services for which these charges are made are being furnished to you pursuant to a service agreement between our company as supplier and the above named customer. Said merchandise is not to be cleaned or laundered other than by our company. Customers are responsible for articles lost or damaged.	Sub Total	\$129.78
	Tax EXEMPT	\$0.00
	Invoice Total	\$129.78



AlSCO
507 North Willow Avenue
Tampa, FL 33606

Phone : (813) 253-0431
Fax : (813) 251-2650

INVOICE

LTAM1116707

Invoice Date: Feb 18 2026
Customer No: 369181
Location No: 369181
Route: 24 Stop: 170
Terms: Net 10 EOM
Purchase Order:

Invoice For

Harbor Bay Mirabay Club
Care Rozzietta Co Arbor Bay CDD
3434 Colwell Ave Ste 200
Tampa, FL 33614-8390

Delivery To

Mirabay Club
107 Manns Harbor Dr
Apollo Beach, FL 33572-3340

Phone : 813-649-1500 ext

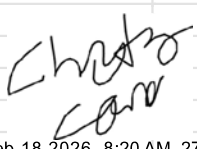
Quantity	Item Code	Item Description	Wearer	Wearer Name	Invty	Item Value
2	9650	Laundry Bag Stand			2	0.00
	5505-GN	Laundry Bag, Green			20	0.00
2	2405	3x10 Mirabay Club			4	27.00
4	2405	4x6 Mirabay Club			8	54.00
	9925	Special Delivery Charge				0.00
	SVCCHG%	Service Charge				27.00
<p>****SPECIAL ****</p> <p>Gloves starting at \$25 per case of 1000</p> <p>Can liners starting at \$18.90 per case of 1000</p> <p>Need gloves or can liners, ask your RSR or call 813-253-0431 to place an order.</p> <p>**Want to add a credit card to your account for payment. Go to the website below and click register for A-Track to view invoices, statements and add payment methods.**</p> <p>https://atrack.alsco.com/Account/Login</p>						
						 CHRISTY C Feb 18 2026, 8:20 AM 27.7485, -82.4176

The services for which these charges are made are being furnished to you pursuant to a service agreement between our company as supplier and the above named customer. Said merchandise is not to be cleaned or laundered other than by our company. Customers are responsible for articles lost or damaged.

Sub Total \$108.00
Tax EXEMPT \$0.00
Invoice Total \$108.00

Aroma Coffee Service, Inc.
2168 Andrea Lane, Fort Myers, Florida 33912
1-800-448-9139 - cs@aromacoffee.net

Invoice # 0223189800

Customer # 8153
MIRABAY CLUB (VISA+)
107 MANNS HARBOR DRIVE
APOLLO BEACH, FL 33572

01/09/26 15:35 - Driver: JOSH JARRETT
PO #:
Blanket PO#:

Taxable Items

1586	Aroma Hot Cup Lids	1	EA	79.95	79.95	T
					79.95	

Non-Taxable Items
NONE

Number of Items: 1
Total Quantity: 1

Taxable \$79.95
Non-Taxable \$0.00

Our records show that you have the following equipment on loan from Aroma Coffee Service at your location:

Description	Qty
Everpure Scale Filter	2
VITRO X5 TOUCH	1

Subtotal: \$ 79.95
Tax: \$0.00
Cash: \$0.00
Check: \$0.00
DUE: \$ 79.95

Customer Signature: 

Printed Name:

Date: **01/09/26**

Aroma Coffee Service, Inc.
 2168 Andrea Lane, Fort Myers, Florida 33912
 1-800-448-9139 - cs@aromacoffee.net

Invoice # 0223191720

Customer # 8153
 MIRABAY CLUB (VISA+)
 107 MANNS HARBOR DRIVE
 APOLLO BEACH, FL 33572

01/29/26 16:22 - Driver: JACOB KNUTSON
 PO #:
 Blanket PO#:

Taxable Items

178	12oz Hot Cups	1	CAS	82.96	82.96	T
					82.96	

Non-Taxable Items

576	Twinnings Chai Tea	1	EA	8.70	8.70	
549	Sweet Creme	1	EA	39.95	39.95	
546	Twinnings Green Tea	2	EA	8.70	17.40	
526	Hazelnut Liquid Creamer Lg	1	CS	39.95	39.95	
346	Cappuccino Topping	28	EA	8.54	239.12	
251	Katie's Decafe Whole Bean	1	EA	79.95	79.95	
2004	Java Nicks Latin Espresso Bean	5	CAS	72.95	364.75	
196	Twinnings Lemon Ginger Tea	2	EA	8.70	17.40	
098	Vending Cocoa	6	EA	10.68	64.08	
067	Half n Half	1	CAS	27.42	27.42	
000	Fuel / Equipment Charge	1	EA	13.00	13.00	

Number of Items: 12
 Total Quantity: 50

Taxable \$82.96
Non-Taxable \$911.72

Our records show that you have the following equipment on loan from Aroma Coffee Service at your location:

Description	Qty
Everpure Scale Filter	2
VITRO X5 TOUCH	1

Subtotal: \$ 994.68
Tax: \$.00
 Cash: \$.00
 Check: \$.00
DUE: \$ 994.68

Customer Signature:

Printed Name:

Date: 01/29/26

Aroma Coffee Service, Inc.
2168 Andrea Lane, Fort Myers, Florida 33912
1-800-448-9139 - cs@aromacoffee.net

Invoice # 0223193300

Customer # 8153
MIRABAY CLUB (VISA+)
107 MANNS HARBOR DRIVE
APOLLO BEACH, FL 33572

02/09/26 13:00 - Driver: JACOB KNUTSON

PO #:

Blanket PO#:

Taxable Items

178	12oz Hot Cups	1	CAS	82.96	82.96	T
1586	Aroma Hot Cup Lids	1	EA	79.95	79.95	T
1427	Cup Sleeves	1	CAS	79.95	79.95	T
					242.86	

Non-Taxable Items

342	Twinnings Breakfast Tea	1	EA	8.70	8.70	
576	Twinnings Chai Tea	1	EA	8.70	8.70	
546	Twinnings Green Tea	2	EA	8.70	17.40	
526	Hazelnut Liquid Creamer Lg	1	CS	39.95	39.95	
425	Vanilla Liquid Creamer Lg	1	EA	39.95	39.95	
421	Lg Liq Non Dairy Cream	1	CAS	26.20	26.20	
346	Cappuccino Topping	24	EA	9.00	216.00	
251	Katie's Decafe Whole Bean	2	CAS	79.95	159.90	
2004	Java Nicks Latin Espresso Bean	3	CAS	72.95	218.85	
196	Twinnings Lemon Ginger Tea	1	EA	8.70	8.70	
098	Vending Cocoa	8	EA	9.00	72.00	
084	Sugar Packets	1	BOX	21.66	21.66	
067	Half n Half	1	CAS	27.42	27.42	
000	Fuel / Equipment Charge	1	EA	13.00	13.00	

Number of Items: 17
Total Quantity: 51

Taxable **\$242.86**
Non-Taxable **\$878.43**

Our records show that you have the following equipment on loan from Aroma Coffee Service at your location:

Description	Qty
Everpure Scale Filter	2
VITRO X5 TOUCH	1

Subtotal: **\$ 1,121.29**
Tax: **\$.00**
Cash: **\$.00**
Check: **\$.00**

DUE: **\$ 1,121.29**

Customer Signature:

Printed Name:

Date: **02/09/26**

Aroma Coffee Service, Inc.
 2168 Andrea Lane, Fort Myers, Florida 33912
 1-800-448-9139 - cs@aromacoffee.net

Invoice # 0223194460

Customer # 8153
 MIRABAY CLUB (VISA+)
 107 MANNS HARBOR DRIVE
 APOLLO BEACH, FL 33572

02/19/26 15:00 - Driver: JACOB KNUTSON
 PO #:
 Blanket PO#:

Taxable Items

1427	Cup Sleeves	1	CAS	79.95	79.95	T
					79.95	

Non-Taxable Items

576	Twinnings Chai Tea	1	EA	8.70	8.70	
549	Sweet Creme	1	EA	39.95	39.95	
546	Twinnings Green Tea	2	EA	8.70	17.40	
346	Cappuccino Topping	25	EA	9.00	225.00	
342	Twinnings Breakfast Tea	1	EA	8.70	8.70	
238	Stevia	1	CAS	49.95	49.95	
2004	Java Nicks Latin Espresso Bean	5	CAS	72.95	364.75	
196	Twinnings Lemon Ginger Tea	2	EA	8.70	17.40	
098	Vending Cocoa	7	EA	9.00	63.00	
000	Fuel / Equipment Charge	1	EA	13.00	13.00	

Number of Items: 11
 Total Quantity: 47

Taxable \$79.95
Non-Taxable \$807.85

Our records show that you have the following equipment on loan from Aroma Coffee Service at your location:

Description	Qty
Everpure Scale Filter	2
VITRO X5 TOUCH	1

Subtotal: \$ 887.80
Tax: \$.00
 Cash: \$.00
 Check: \$.00
DUE: \$ 887.80

Customer Signature:

Printed Name:

Date: 02/19/26

HARBOR BAY COMMUNITY DEVELOPMENT DISTRICT

District Office – Wesley Chapel, Florida (813) 994-1001
Mailing Address – 3434 Colwell Avenue Suite 200, Tampa, Florida 33614
www.harborbaycdd.org

Check Request

Amount: \$900.00

Date: 02/10/26

Payable to: Chastity Kelly

Address: 107 Manns Harbor Drive
Apollo Beach, FL 33572

Description: Reimbursement for Payment of Invoice 1001 Dave & Jen
Band

Requestor: Venessa Smith

INVOICE



Date: 2/6/20

No. Invoice: 1001

Bill to: Bizzetto CO.

Date	Item Description	Price	Qty	Total
2/6/20	Dance: Jan Bond			
	Rel by charity kully	900.00	1	900.00

THANK YOU!

Total: 900.00

[Signature]



ONE CHENEY WAY • PUNTA GORDA, FL 33982-4401
FOOD SERVICE DISTRIBUTORS

DELIVERING
Southern Hospitality
 SINCE 1988

BILL TO:
 MIRA BAY CLUB
 HARBOR BAY CDD
 107 MANNS HARBOR DR
 APOLLO BEACH FL 33572 US

#60432201

SHIP TO:
 MIRA BAY CLUB
 HARBOR BAY CDD
 107 MANNS HARBOR DR
 APOLLO BEACH FL 33572 US

DD RF
 DW 06:30-10:30
 (813) 649-1500

www.cheneybrothers.com

INVOICE NO.	PAGE	CLK	CHD BY
06-910012119	1	ART	
CUSTOMER NO.	TIME	MO.	DAY
60432201	18:35	02	05 26

TAX ID: 858012574204C8

SPECIAL INSTRUCTIONS				TERMS	SALESPERSON	PUN	WATS	FAX	P.O. NUMBER	ROUTE	STOP
				1 WK DUE TR (WKY)	DUE: 02/12/2026 JILL COX 12391	941.505.5885	844.234.1341	941.505.5886	1	4014	14
LINE	LOCATION	CASES	PKGS.	ITEM NO.	BRAND	PACK SIZE	DESCRIPTION	WEIGHT	UNIT PRICE	CS	AMOUNT
10	FY-091-01	1 C.O.		284004	VILLA	001/9 CT	PIZZA FOUR CHEESE 16"	26.96	107.70		107.70
							cs ___pk r m s d ck'd by ___				
							***** 03-FREEZER *****				107.70
							03-FREEZER	107.70			

The perishable agricultural commodities listed on this invoice are sold subject to the statutory trust authorized by section 5(c) of the Perishable Agricultural Commodities Act, 1930 (7 U.S.C. 499e(c)). The seller of these commodities retains a trust claim over these commodities, all inventories of food or other products derived from these commodities, and any receivables or proceeds from the sale of these commodities until full payment is received. Reel Fresh product noted with "Refresh" on the invoice has been thawed from previously frozen product. Cert # FL-2033-SS Wholesale # WD-7867



910012119

52000-3100

TOTAL QTY. THIS PAGE	1	TERMS: BALANCE DUE UPON RECEIPT OF STATEMENT PURCHASER IS RESPONSIBLE FOR SERVICE CHARGE OF 1-12% PER MONTH (18% PER YEAR) ON PAST DUE ACCOUNTS AND ALL COSTS OF COLLECTION, INCLUDING ATTORNEY FEES, REGARDLESS WHETHER SUIT IS INSTITUTED. PALM BEACH COUNTY IS EXCLUSIVE VENUE FOR SUITS REGARDING COLLECTION OF DELINQUENT ACCOUNTS AND THE SALE OF THE ABOVE GOODS.	RECEIVED BY:	26.96	Estimated Total
TOTAL QTY. THIS INVOICE	1		THE ABOVE LISTED MERCHANDISE HAS BEEN RECEIVED, IN GOOD CONDITION, UNLESS OTHERWISE NOTED ON THE "DELIVERY COPY". CBI reserves the right to retain possession of products until all products and services are paid for in compliance with terms.		\$ 107.70

All values in US Dollars



ONE CHENEY WAY • PUNTA GORDA, FL 33982-4401
FOOD SERVICE DISTRIBUTORS

DELIVERING
Southern Hospitality
 SINCE 1925

BILL TO:
 MIRA BAY CLUB
 HARBOR BAY CDD
 107 MANNS HARBOR DR
 APOLLO BEACH FL 33572 US

#60432201

SHIP TO:
 MIRA BAY CLUB
 HARBOR BAY CDD
 107 MANNS HARBOR DR
 APOLLO BEACH FL 33572 US

DD RF
 DW 06:30-10:30
 (813) 649-1500

www.cheneybrothers.com

INVOICE NO.	PAGE	CLK	CH'D BY
06-910013420	1	MBL	
CUSTOMER NO.	TIME	MO.	DAY
60432201	20:04	02	05 26

TAX ID: 858012574204C8

SPECIAL INSTRUCTIONS	TERMS	SALESPERSON	PUN 941.505.5885	P.O. NUMBER	ROUTE	STOP
	1 WK DUE	DUE: 02/12/2026	WATS 844.234.1341	0	4014	14
	TR (WKY)	JILL COX 12391	FAX 941.505.5886			

LINE	LOCATION	CASES	PKGS.	ITEM NO.	BRAND	PACK/SIZE	DESCRIPTION	WEIGHT	UNIT PRICE	AMOUNT
70	HZ-214-1	1		10035658	FACTLY	024/6 OZ	FRYER CLEANER AND MULTI PURP DEGREASER FRYOLATER MULTI-PURPOSE DEGREASER	9.00	50.90	CS 50.90
		C.O.					ck'd by ____			
80	HZ-110-1	1		10091370	SWISHE	004/1 GAL	DEGREASER & FLOOR CLEANER HEAVY DUTY	35.60	63.56	CS 63.56
		C.O.					ck'd by ____			
110	HZ-264-1	1		10138055	DAWN	004/1 GAL	DETERGENT DAWN PROF LIQUID DISH W/PUMP	35.56	93.43	CS 93.43
							ck'd by ____			
10	DE-262-1		2	76055	MARZET	004/1 GAL	DRESSING ROYAL CAESAR 5 STAR WITH EGG DOT#719507	17.10	29.07	PK 58.14
							ck'd by ____			
20	DE-252-1	1		156133	STANIS	006/# 10	SAUCE PIZZA FULLY PREPARED	47.00	49.03	CS 49.03
		C.O.					ck'd by ____			
50	DE-136-1	1		292148	HERMAN	008/12 CT	TORTILLA FLOUR 12" PRESSED	21.60	28.81	CS 28.81
		C.O.					ck'd by ____			
30	CC-172-1		2	178305	FRONTE	004/5 #	CHEESE MOZZARELLA SHREDDED PART SKIM	10.00	3.18	#N 31.80
							ck'd by ____			
40	CC-262-1	1		204615	GW EST	032/8 OZ	BEEF GROUND PATTY ANGUS STK 80/20	16.00	5.93	#N 94.88
		C.O.					ck'd by ____			
60	FA-163-1	2		10017710	LAMB	006/5 #	FRY SEA SHORE SKIN ON THICK CUT	60.00	67.48	CS 134.96
		C.O.					ck'd by ____			

TOTAL QTY. THIS PAGE	8	4	TERMS: BALANCE DUE UPON RECEIPT OF STATEMENT. PURCHASER IS RESPONSIBLE FOR SERVICE CHARGE OF 1-1/2% PER MONTH (18% PER YEAR) ON PAST DUE ACCOUNTS AND ALL COSTS OF COLLECTION, INCLUDING ATTORNEY FEES REGARDLESS WHETHER SUIT IS INSTITUTED. PALM BEACH COUNTY IS EXCLUSIVE VENUE FOR SUITS REGARDING COLLECTION OF DELINQUENT ACCOUNT(S) AND THE SALE OF THE ABOVE GOODS.	RECEIVED BY:	Estimated Total
TOTAL QTY. THIS INVOICE				THE ABOVE LISTED MERCHANDISE HAS BEEN RECEIVED IN GOOD CONDITION, UNLESS OTHERWISE NOTED ON THE DELIVERY COPY. CBI reserves the right to retake possession of products until all products and services are paid for in compliance with terms.	CONTINUE

All values in US Dollars



ONE CHENEY WAY • PUNTA GORDA, FL 33982-4401
FOOD SERVICE DISTRIBUTORS

DELIVERING
Southern Hospitality
 SINCE 1988

#60432201

BILL TO:
 MIRA BAY CLUB
 HARBOR BAY CDD
 107 MANNS HARBOR DR
 APOLLO BEACH FL 33572 US

SHIP TO:
 MIRA BAY CLUB
 HARBOR BAY CDD
 107 MANNS HARBOR DR
 APOLLO BEACH FL 33572 US

DD RF
 DW 06:30-10:30
 (813) 649-1500

www.cheneybrothers.com

INVOICE NO.	PAGE	CLK	CH'D BY
06-910013420	2	MBL	
CUSTOMER NO.	TIME	MO.	DAY YR.
60432201	20:04	02	05 26

TAX ID: 858012574204C8

SPECIAL INSTRUCTIONS	TERMS	SALESPERSON	PUN 941.505.5885	P.O. NUMBER	ROUTE	STOP
	1 WK DUE TR (WKY)	DUE: 02/12/2026 JILL COX 12391	WATS 844.234.1341 FAX 941.505.5886	0	4014	14

LINE	LOCATION	CASES	PKGS.	ITEM NO.	BRAND	PACK/SIZE	DESCRIPTION	WEIGHT	UNIT PRICE	AMOUNT
90	FF-592-2	2 C.O.		10110960	TYSON	002/5 #	CHIX TENDER FRITTER HMESTYLE RTC NAE	20.00	36.91	CS 73.82
100	FE-247-1	1 C.O.		10131569	RICHS	014/18 OZ	PIZZA CRUST 16 IN PAR BAKED TRADITIONAL	15.75	52.91	CS 52.91
1							***** 03-FREEZER ***** FUEL SURCHARGE		0.00	261.69 5.00
							***** TOTAL DISCOUNT/SURCHARGE *****			5.00
01-DRY GOODS			135.98	02-COOLER		126.68	03-FREEZER	261.69	98 CHEMICALS	207.89

The perishable agricultural commodities listed on this invoice are sold subject to the statutory trust authorized by section 5(c) of the Perishable Agricultural Commodities Act, 1930 (7 U.S.C. 499e(c)). The seller of these commodities retains a trust claim over these commodities, all inventories of food or other products derived from these commodities, and any receivables or proceeds from the sale of these commodities until full payment is received. Reel Fresh product noted with "Refresh" on the invoice has been thawed from previously frozen product. Cert # FL-2033-SS Wholesale # WD-7867



910013420

52000-3122

TOTAL QTY. THIS PAGE ➤	3	TERMS: BALANCE DUE UPON RECEIPT OF STATEMENT. PURCHASER IS RESPONSIBLE FOR SERVICE CHARGE OF 1-1/2% PER MONTH (18% PER YEAR) ON PAST DUE ACCOUNTS AND ALL COSTS OF COLLECTION, INCLUDING ATTORNEY FEES REGARDLESS WHETHER SUIT IS INSTITUTED. PALM BEACH COUNTY IS EXCLUSIVE VENUE FOR SUITS REGARDING COLLECTION OF DELINQUENT ACCOUNT(S) AND THE SALE OF THE ABOVE GOODS.	RECEIVED BY: THE ABOVE LISTED MERCHANDISE HAS BEEN RECEIVED IN GOOD CONDITION, UNLESS OTHERWISE NOTED ON THE "DELIVERY COPY". CBI reserves the right to retake possession of products until all products and services are paid for in compliance with terms.	287.61	Estimated Total
TOTAL QTY. THIS INVOICE ➤	11			4	

All values in US Dollars



ONE CHENEY WAY • PUNTA GORDA, FL 33982-4401
FOOD SERVICE DISTRIBUTORS

DELIVERING
Southern Hospitality
 SINCE 1933

#60432201

BILL TO:
 MIRA BAY CLUB
 HARBOR BAY CDD
 107 MANNS HARBOR DR
 APOLLO BEACH FL 33572 US

SHIP TO:
 MIRA BAY CLUB
 HARBOR BAY CDD
 107 MANNS HARBOR DR
 APOLLO BEACH FL 33572 US

DD RF
 DW 06:30-10:30
 (813) 649-1500

www.cheneybrothers.com			
INVOICE NO.	PAGE	CLK	CH'D BY
06-910058187	1	MBL	
CUSTOMER NO.	TIME	MO.	DAY YR.
60432201	20:42	02	12 26

TAX ID: 858012574204C8

SPECIAL INSTRUCTIONS				TERMS	SALESPERSON	PUN 941.505.5885	P.O. NUMBER	ROUTE	STOP
				1 WK DUE	DUE: 02/19/2026	WATS 844.234.1341	0	4004	13
				TR (WKY)	JILL COX 12391	FAX 941.505.5886			

LINE	LOCATION	CASES	PKGS.	ITEM NO.	BRAND	PACK/SIZE	DESCRIPTION	WEIGHT	UNIT PRICE	AMOUNT
20	ES-553-1	1		8017	TASTE	001/120 CT	SHELLS CANNOLI SMALL 3"	3.24	43.05	CS 43.05
		C.O.					ck'd by ____			
30	DE-262-1		1	76055	MARZET	004/1 GAL	DRESSING ROYAL CAESAR 5 STAR WITH EGG	8.55	29.07	PK 29.07
							ck'd by ____			
40	EW-518-1	1		94013	LAYS	002/30 CT	CHIPS VARIETY PACK LAYS 1.5 OZ TO 2 OZ	6.40	48.51	CS 48.51
		C.O.					ck'd by ____			
50	DF-650-1	2		100034	FRONTE	024/16.9 OZ	WATER FRONTE PRIMO 16.9 OZ NEW PLASTIC BOTTLE	60.00	12.32	CS 24.64
		C.O.					ck'd by ____			
60	DC-101-1	2		118033	CBI	001/35 #	SHORTENING CLEAR LIQUID TRANS FAT FREE 50340	70.00	34.47	CS 68.94
		C.O.					ck'd by ____			
160	DQ-523-2	1		466115	CBI	001/5 #	TOMATOES 5X6 5 LBS AVG	5.00	12.80	CS 12.80
		C.O.					ck'd by ____			
70	CC-262-1	1		204615	GW EST	032/8 OZ	BEEF GROUND PATTY ANGUS STK 80/20	16.00	5.93	#N 94.88
		C.O.					ck'd by ____			
150	CM-228-1	1		432381	CBI	006/1 CT	CUCUMBERS SUPER 6 COUNT	5.00	6.60	CS 6.60
		C.O.					ck'd by ____			
180	CK-307-1	1		10120604	CBI	001/3 CT	LETTUCE ICEBERG WRAPPED 3 COUNT	10.00	13.79	CS 13.79
		C.O.					ck'd by ____			
***** 01-DRY GOODS *****										227.01
***** 02-COOLER *****										115.27

TOTAL QTY. THIS PAGE	10	1	TERMS: BALANCE DUE UPON RECEIPT OF STATEMENT PURCHASER IS RESPONSIBLE FOR SERVICE CHARGE OF 1-1/2% PER MONTH (18% PER YEAR) ON PAST DUE ACCOUNTS AND ALL COSTS OF COLLECTION, INCLUDING ATTORNEY FEES, REGARDLESS WHETHER SUIT IS INSTITUTED. PALM BEACH COUNTY IS EXCLUSIVE VENUE FOR SUITS REGARDING COLLECTION OF DELINQUENT ACCOUNT(S) AND THE SALE OF THE ABOVE GOODS.	RECEIVED BY:	THE ABOVE LISTED MERCHANDISE HAS BEEN RECEIVED IN GOOD CONDITION UNLESS OTHERWISE NOTED ON THE "DELIVERY COPY" CBI reserves the right to retake possession of products until all products and services are paid for in compliance with terms.	Estimated Total	CONTINUE
TOTAL QTY. THIS INVOICE							

All values in US Dollars



ONE CHENEY WAY • PUNTA GORDA, FL 33982-4401
FOOD SERVICE DISTRIBUTORS

DELIVERING
Southern Hospitality
 SINCE 1928

#60432201

www.cheneybrothers.com

BILL TO:
 MIRA BAY CLUB
 HARBOR BAY CDD
 107 MANNS HARBOR DR
 APOLLO BEACH FL 33572 US

SHIP TO:
 MIRA BAY CLUB
 HARBOR BAY CDD
 107 MANNS HARBOR DR
 APOLLO BEACH FL 33572 US

DD RF
 DW 06:30-10:30
 (813) 649-1500

INVOICE NO.	PAGE	CLK	CH'D BY
06-910058187	2	MBL	
CUSTOMER NO.	TIME	MO.	DAY
60432201	20:42	02	12 26

TAX ID: 858012574204C8

SPECIAL INSTRUCTIONS				TERMS	SALESPERSON	PUN	WATS	FAX	P.O. NUMBER	ROUTE	STOP	
				1 WK DUE	DUE: 02/19/2026	941.505.5885	844.234.1341	941.505.5886	0	4004	13	
				TR (WKY)	JILL COX 12391							
LINE	LOCATION	CASES	PKGS.	ITEM NO.	BRAND	PACK/SIZE	DESCRIPTION	WEIGHT	UNIT PRICE	CS	AMOUNT	
10	FJ-630-1	1		8013	TASTE	004/1.5 #	CREAM CANNOLI WITH CHOCOLATE CHIPS	4.99	39.88	CS	39.88	
		C.O.										
80	FD-644-1	1		220025	SMITHF	001/15 #	BACON APPLEWOOD SMOKED 14/18 LAYOUT SILVER MEDAL	15.00	4.49	#N	67.35	
		C.O.										
90	FA-239-1	1		226035	AGRO	004/10 #	CHIX BREAST FILET IQF 6 OZ BNLS/SKNLS MARINT SINGLE LOBE	40.00	3.21	#N	128.40	
		C.O.										
100	FI-150-2	1		234021	PERDUE	002/5 #	CHIX TENDERS BREADED FC WHOLE MUSCLE FULL COOKED	10.00	66.31	CS	66.31	
		C.O.										
110	FD-526-2	1		246021	CENSEA	005/2 #	SHRIMP 21/25 RAW P&D T/OFF FAR EAST WHITE	10.00	7.62	#N	76.20	
		C.O.										
120	FB-634-2	2		276090	STOUFF	004/96 OZ	LASAGNA MEAT	50.00	116.39	CS	232.78	
		C.O.										
130	FF-625-2C	1		276100	STOUFF	004/6 #	LASAGNA VEGETABLE	24.00	103.90	CS	103.90	
		C.O.										
140	FH-639-2	1		302001	PEP FA	016/8 CT	BREAD GARLIC TEXAS TOAST SLICED	12.21	54.64	CS	54.64	
		C.O.										
170	FJ-528-3A	1		10095082	BELGIU	002/4.5 #	BUTTER SCAMPI BLEND TUB CBL2067-T	10.00	71.91	CS	71.91	
		C.O.										
1					***** 03-FREEZER *****							841.37
							FUEL SURCHARGE		0.00		5.00	
					***** TOTAL DISCOUNT/SURCHARGE *****							5.00

TOTAL QTY. THIS PAGE	10	TERMS: BALANCE DUE UPON RECEIPT OF STATEMENT. PURCHASER IS RESPONSIBLE FOR SERVICE CHARGE OF 1-1/2% PER MONTH (18% PER YEAR) ON PAST DUE ACCOUNTS AND ALL COSTS OF COLLECTION, INCLUDING ATTORNEY FEES REGARDLESS WHETHER SUIT IS INSTITUTED. PALM BEACH COUNTY IS EXCLUSIVE VENUE FOR SUITS REGARDING COLLECTION OF DELINQUENT ACCOUNTS; AND THE SALE OF THE ABOVE GOODS.	RECEIVED BY:	Estimated Total
TOTAL QTY. THIS INVOICE			THE ABOVE LISTED MERCHANDISE HAS BEEN RECEIVED IN GOOD CONDITION UNLESS OTHERWISE NOTED ON THE "DELIVERY COPY". CBI reserves the right to retain possession of products until all products and services are paid for in compliance with terms.	CONTINUE

All values in US Dollars



ONE CHENEY WAY • PUNTA GORDA, FL 33982-4401
FOOD SERVICE DISTRIBUTORS

DELIVERING
Southern Hospitality
 SINCE 1928

#60432201

www.cheneybrothers.com

BILL TO:
 MIRA BAY CLUB
 HARBOR BAY CDD
 107 MANNS HARBOR DR
 APOLLO BEACH FL 33572 US

SHIP TO:
 MIRA BAY CLUB
 HARBOR BAY CDD
 107 MANNS HARBOR DR
 APOLLO BEACH FL 33572 US

DD RF
 DW 06:30-10:30
 (813) 649-1500

INVOICE NO.	PAGE	CLK	CH'D BY
06-910058187	3	MBL	
CUSTOMER NO.	TIME	MO.	DAY
60432201	20:42	02	12 26

TAX ID: 858012574204C8

SPECIAL INSTRUCTIONS	TERMS	SALESPERSON	PUN	941.505.5885	P.O. NUMBER	ROUTE	STOP
	1 WK DUE	DUE: 02/19/2026	WATS	844.234.1341	0	4004	13
	TR (WKY)	JILL COX 12391	FAX	941.505.5886			

LINE	LOCATION	CASES	PKGS.	ITEM NO.	BRAND	PACK/SIZE	DESCRIPTION	WEIGHT	UNIT PRICE	AMOUNT
01	DRY GOODS	227.01		02-COOLER		115.27	03-FREEZER	841.37		

The perishable agricultural commodities listed on this invoice are sold subject to the statutory trust authorized by section 5(c) of the Perishable Agricultural Commodities Act, 1930 (7 U.S.C. 499e(c)). The seller of these commodities retains a trust claim over these commodities, all inventories of food or other products derived from these commodities, and any receivables or proceeds from the sale of these commodities until full payment is received. Reel Fresh product noted with "Refresh" on the invoice has been thawed from previously frozen product. Cert # FL-2033-SS Wholesale # WD-7867



910058187

52000-4842 = 655.55
 52000-3122 = 533.10

TOTAL QTY. THIS PAGE	TOTAL QTY. INVOICE	20	1	TERMS: BALANCE DUE UPON RECEIPT OF STATEMENT. PURCHASER IS RESPONSIBLE FOR SERVICE CHARGE OF 1-1/2% PER MONTH (18% PER YEAR) ON PAST DUE ACCOUNTS AND ALL COSTS OF COLLECTION, INCLUDING ATTORNEY FEES REGARDLESS WHETHER SUIT IS INSTITUTED. PALM BEACH COUNTY IS EXCLUSIVE VENUE FOR SUITS REGARDING COLLECTION OF DELINQUENT ACCOUNT(S) AND THE SALE OF THE ABOVE GOODS.	RECEIVED BY:	360.39	Estimated Total
							\$ 1,188.65

All values in US Dollars

Cheney Brothers

One Cheney Way, Punta Gorda, FL 33982, Phone: (561) 845-4700

Customer # 60432201
 MIRA BAY CLUB
 107 MANNS HARBOR DR
 APOLLO BEACH, FL 33572
 8136491500

Invoice # 06-910101845
 Route # 4015
 Stop # 14
 Delivery Date: 02/19/2026
 Delivery Time: 11:07 AM
 Driver: 19413
 Date Due: 02/26/2026
 Page Count: 1 of 3

Terms	Tax ID	Sales Representative	P.O. #
1 WK DUE T	858012574204C8	012391 JILL COX	0

Ln	Cs/PK	Item	Brand	PK-Size	Description	Price	Amount	
10	2	094013	LAYS	002/30	CHIPS VARIETY PACK	48.51	97.02	
20	1	118033	CBI	001/35	SHORTENING CLEAR L	34.47	34.47	
130	1	707901	NIAGARA	020/1	PAD SPONGE YELLOW	14.30	14.30	
140	1	798534	KENS	002/1	MAYONNAISE CHIPOTL	49.52	49.52	
150	2	805215	OMEGA	001/100	CAN LINER LD 38X58	52.45	104.90	
170	1	10026720	SWT B RA	004/1	SAUCE WING BUFFALO	23.95	23.95	
220	2	10097741	M VICKIE	002/30	CHIPS VARIETY MISS	48.49	96.98	
250	2	10132395	CBI	010/100	GLOVES NITRILE BLA	42.31	84.62	
260	1	10158576	TORK	012/250	TOWEL MULTFOLD COM	35.20	35.20	
**	12	1	SUB TOTAL FOR: 01-DRY GOODS					540.96
30	2	168020	SCHREIBE	004/5	CHEESE CHEDDAR JAC 5.00 5.00 TOT WT: 10.00	3.32	33.20	
40	1	174039	GRANDE	010/3	CHEESE PARMESAN SH TOT WT: 3.00	8.00	24.00	
50	1	178300	FRONTE	004/5	CHEESE MOZZARELLA TOT WT: 20.00	3.05	61.00	
60	3	204615	GW ESTAT	032/8	BEEF GROUND PATTY 16.00 16.00 16.00 TOT WT: 48.00	5.93	284.64	
90	1	412500	CBI	001/2	LEMONS FANCY 2 LBS	8.16	8.16	
100	1	414500	CBI	001/2	LIMES 2 LBS BAG	8.78	8.78	
110	1	436400	CBI	004/6	LETTUCE ROMAINE LI	50.65	50.65	
120	2	448016	CBI	006/1	PEPPERS GREEN LAR	11.48	22.96	
230	1	10112498	BELGIOSO	002/8	CHEESE BLUE WHEELS TOT WT: 8.00	6.03	48.24	
240	2	10120604	CBI	001/3	LETTUCE ICEBERG WR	13.79	27.58	
**	11	4	SUB TOTAL FOR: 02-COOLER					569.21
70	1	214069	DUCKDELI	002/5	FRANK BEEF 5/1 7" TOT WT: 10.00	5.52	55.20	
80	4	234021	PERDUE	002/5	CHIX TENDERS BREAD	66.31	265.24	
160	2	10017710	LAMB	006/5	FRY SEA SHORE SKIN	67.48	134.96	
180	1	10026930	LAKE ERI	006/2	MOZZARELLA STICKS	47.52	47.52	
190	1	10044750	GARDEIN	048/4.2	BURGER BLACK BEAN	94.46	94.46	
200	1	10058923	TURANO	012/8	ROLL HOT DOG GOURM	52.97	52.97	
210	1	10061453	CAKERIE	002/176	CAKE BLACK FOREST	142.05	142.05	
**	11		SUB TOTAL FOR: 03-FREEZER					792.40

Cheney Brothers

One Cheney Way , Punta Gorda, FL 33982, Phone: (561) 845-4700

Customer # 60432201
 MIRA BAY CLUB
 107 MANNS HARBOR DR
 APOLLO BEACH, FL 33572
 8136491500

Invoice # 06-910101845
 Route # 4015
 Stop # 14
 Delivery Date: 02/19/2026
 Delivery Time: 11:07 AM
 Driver: 19413
 Date Due: 02/26/2026
 Page Count: 2 of 3

Terms	Tax ID	Sales Representative	P.O. #
1 WK DUE T	858012574204C8	012391 JILL COX	0

Ln	Cs/PK	Item	Brand	PK-Size	Description	Price	Amount
		990008			FUEL SURCHARGE		5.00
		01-DRY GOODS		540.96	03-FREEZER	792.40	
		02-COOLER		569.21			
		Total				Tax Rt	N/A
		Received By:				Tax	
						Total	1907.57
		Printed Name:				Due	1907.57
		lj				OnAcct	1907.57

52800-4519 = 140.10
 52000-4415 = 98.92
 52000-3122 = 1,468.55

Cheney C-B-I Brothers

One Cheney Way , Punta Gorda, FL 33982, Phone: (561) 845-4700

Customer # 60432201
MIRA BAY CLUB
107 MANNS HARBOR DR
APOLLO BEACH, FL 33572
8136491500

Invoice # 06-910101845
Route # 4015
Stop # 14
Delivery Date: 02/19/2026
Delivery Time: 11:07 AM
Driver: 19413
Date Due: 02/26/2026
Page Count: 3 of 3

Terms	Tax ID	Sales Representative	P.O. #
1 WK DUE T	858012574204CB	012391 JILL COX	0

Ln	Cs/PK	Item	Brand	PK-Size	Description	Price	Amount
----	-------	------	-------	---------	-------------	-------	--------

***** THANK YOU FOR YOUR BUSINESS! *****

BY SIGNING THIS INVOICE BUYER ACKNOWLEDGES THAT THE ABOVE MERCHANDISE HAS BEEN RECEIVED, IN GOOD CONDITION, UNLESS OTHERWISE NOTED ON THE "DELIVERY COPY".

The perishable agricultural commodities listed on this invoice are sold subject to the statutory trust authorized by section 5(c) of the Perishable Agricultural Commodities Act, 1930 (7 U.S.C. 499e(c)). The seller of these commodities retains a trust claim over these commodities, all inventories of food or other products derived from these commodities, and any receivables or proceeds from the sale of these commodities until full payment is received. Reel Fresh product noted with "Refresh" on the invoice has been thawed from previously frozen product. Cert # FL-2033-SS Wholesale # WD-7867

Buyer agrees to pay all of seller's costs of collection of amounts due hereunder and enforcement of seller's PACA trust rights, including reasonable attorneys' fees in all such proceedings. Interest will accrue on any past-due balance at the rate of 1 1/2% per month (18% per year) or the maximum rate of interest allowable by law. Seller reserves the right to retake possession of products until amounts due are paid in full. Prices reflected on this invoice may be subject to promotional allowances, volume discounts, corporate rebates or other programs.

Please contact your Salesperson, 012391 JILL COX, if you have any questions.

Cheney C-B-I Brothers

One Cheney Way , Punta Gorda, FL 33982, Phone: (561) 845-4700

Customer # 60432201
MIRA BAY CLUB
107 MANNS HARBOR DR
APOLLO BEACH, FL 33572
8136491500

Invoice # 06-910109247
Route # 5002
Stop # 10
Delivery Date: 02/20/2026
Delivery Time: 07:49 AM
Driver: 19413
Date Due: 02/26/2026
Page Count: 1 of 2

Terms	Tax ID	Sales Representative	P.O. #
1 WK DUE T	858012574204C8	012391 JILL COX	0

Ln	Cs/PK	Item	Brand	PK-Size	Description	Price	Amount	
10	1	425050	CBI	048/1	AVOCADO HALVES 48	39.32	39.32	
30	1	10072261	HOOD	100/1	CREAM SOUR CUP	17.05	17.05	
40	1	198018	RESERS	003/8	SALAD MACARONI ELB	57.40	57.40	
	1	*- 198018	RESERS	003/8	SALAD MACARONI ELB		*-OUT-*	
		2 CS SHORTED BY 1 CS						
**	3	SUB TOTAL FOR: 02-COOLER						113.77
20	2	10066772	PIANTEDO	096/3-25	BUN HAMBURGER POTA	70.35	140.70	
**	2	SUB TOTAL FOR: 03-FREEZER						140.70
		990008			FUEL SURCHARGE		5.00	
		02-COOLER		113.77	03-FREEZER		140.70	
Total		Received By:				Tax Rt	N/A	
5 0						Tax		
						Total	259.47	
						Due	259.47	
		Printed Name:				OnAcct	259.47	
		lj						

52000-3122

Cheney Brothers

One Cheney Way , Punta Gorda, FL 33982, Phone: (561) 845-4700

Customer # 60432201
MIRA BAY CLUB
107 MANN'S HARBOR DR
APOLLO BEACH, FL 33572
8136491500

Invoice # 06-910109247
Route # 5002
Stop # 10
Delivery Date: 02/20/2026
Delivery Time: 07:49 AM
Driver: 19413
Date Due: 02/26/2026
Page Count: 2 of 2

Terms	Tax ID	Sales Representative	P.O. #
1 WK DUE T	858012574204C8	012391 JILL COX	0

Ln	Cs/PK	Item	Brand	PK-Size	Description	Price	Amount
----	-------	------	-------	---------	-------------	-------	--------

***** THANK YOU FOR YOUR BUSINESS! *****

BY SIGNING THIS INVOICE BUYER ACKNOWLEDGES THAT THE ABOVE MERCHANDISE HAS BEEN RECEIVED, IN GOOD CONDITION, UNLESS OTHERWISE NOTED ON THE "DELIVERY COPY".

The perishable agricultural commodities listed on this invoice are sold subject to the statutory trust authorized by section 5(c) of the Perishable Agricultural Commodities Act, 1930 (7 U.S.C. 499e(c)). The seller of these commodities retains a trust claim over these commodities, all inventories of food or other products derived from these commodities, and any receivables or proceeds from the sale of these commodities until full payment is received. Reel Fresh product noted with "Refresh" on the invoice has been thawed from previously frozen product. Cert # FL-2033-SS Wholesale # WD-7867

Buyer agrees to pay all of seller's costs of collection of amounts due hereunder and enforcement of seller's PACA trust rights, including reasonable attorneys' fees in all such proceedings. Interest will accrue on any past-due balance at the rate of 1 1/2 % per month (18% per year) or the maximum rate of interest allowable by law. Seller reserves the right to retake possession of products until amounts due are paid in full. Prices reflected on this invoice may be subject to promotional allowances, volume discounts, corporate rebates or other programs.

Please contact your Salesperson, 012391 JILL COX, if you have any questions.



ONE CHENEY WAY • PUNTA GORDA, FL 33982-4401
FOOD SERVICE DISTRIBUTORS

DELIVERING
Southern Hospitality
 SINCE 1988

#60432201

BILL TO:
 MIRA BAY CLUB
 HARBOR BAY CDD
 107 MANNS HARBOR DR
 APOLLO BEACH FL 33572 US

SHIP TO:
 MIRA BAY CLUB
 HARBOR BAY CDD
 107 MANNS HARBOR DR
 APOLLO BEACH FL 33572 US

DD RF
 DW 06:30-19:00
 (813) 649-1500

www.cheneybrothers.com

INVOICE NO.	PAGE	CLK	CH'D BY
06-929954533	1	C4S	
CUSTOMER NO.	TIME	MO.	DAY
60432201	18:00	01	27 26

TAX ID: 858012574204C8

SPECIAL INSTRUCTIONS		TERMS	SALESPERSON	PUN 941.505.5885	P.O. NUMBER	ROUTE	STOP
		1 WK DUE	DUE: 02/05/2026	WATS 844.234.1341	1	2002	01
		TR (WKY)	JILL COX 12391	FAX 941.505.5886			

LINE	LOCATION	CASES	PKGS.	ITEM NO.	BRAND	PACK/SIZE	DESCRIPTION	WEIGHT	UNIT PRICE	AMOUNT
10	CD-521-1	1		204055	GWB	002/10 # AVG	BEEF GROUND BULK	18.50	5.62	# 103.97
		C.O.					81/19			
							ck'd by			
							18.50			
							***** 02-COOLER *****			103.97
							ROUTED VIA			
							DO NOT DELIVER TO CUSTOMER!!			
							GIVE PRODUCT TO SALES REP.			
							02-COOLER			103.97

The perishable agricultural commodities listed on this invoice are sold subject to the statutory trust authorized by section 5(c) of the Perishable Agricultural Commodities Act, 1930 (7 U.S.C. 499e(c)). The seller of these commodities retains a trust claim over these commodities, all inventories of food or other products derived from these commodities, and any receivables or proceeds from the sale of these commodities until full payment is received. Reel Fresh product noted with "Refresh" on the invoice has been thawed from previously frozen product. Cert # FL-2033-SS Wholesale # WD-7867



929954533

TOTAL QTY. THIS PAGE	1	TERMS: BALANCE DUE UPON RECEIPT OF STATEMENT. PURCHASER IS RESPONSIBLE FOR SERVICE CHARGE OF 1-1/2% PER MONTH (18% PER YEAR) ON PAST DUE ACCOUNTS AND ALL COSTS OF COLLECTION, INCLUDING ATTORNEY FEES REGARDLESS WHETHER SUIT IS INSTITUTED. PALM BEACH COUNTY IS EXCLUSIVE VENUE FOR SUITS REGARDING COLLECTION OF DELINQUENT ACCOUNT(S) AND THE SALE OF THE ABOVE GOODS.	18.50	Estimated Total
TOTAL QTY. THIS INVOICE	1	RECEIVED BY:		\$ 103.97

All values in US Dollars



ONE CHENEY WAY • PUNTA GORDA, FL 33982-4401
FOOD SERVICE DISTRIBUTORS

DELIVERING
Southern Hospitality
 SINCE 1978

#60432201

www.cheneybrothers.com

BILL TO:
 MIRA BAY CLUB
 HARBOR BAY CDD
 107 MANNS HARBOR DR
 APOLLO BEACH FL 33572 US

SHIP TO:
 MIRA BAY CLUB
 HARBOR BAY CDD
 107 MANNS HARBOR DR
 APOLLO BEACH FL 33572 US

DD RF
 DW 06:30-10:30
 (813)649-1500

INVOICE NO.	PAGE	CLK	CH'D BY
06-929970007	1	MBL	
CUSTOMER NO.	TIME	MO.	DAY YR.
60432201	18:21	01	29 26
TAX ID: 858012574204C8			

SPECIAL INSTRUCTIONS	TERMS	SALESPERSON	PUN 941.505.5885	P.O. NUMBER	ROUTE	STOP
	1 WK DUE	DUE: 02/05/2026	WATS 844.234.1341	0	4005	12
	TR (WKY)	JILL COX 12391	FAX 941.505.5886			

LINE	LOCATION	CASES	PKGS	ITEM NO.	BRAND	PACK/SIZE	DESCRIPTION	WEIGHT	UNIT PRICE	CS	AMOUNT
10	DF-641-1	1		116045	WESSON	003/1 GAL	BUTTER LIQUID SUB BEYOND BUTTER WESSON PRO PERFORMANCE BUTTER ALT.	24.80	39.89	CS	39.89
							___cs ___pk r m s d ck'd by ___				
							***** 01-DRY GOODS *****				39.89
80	CC-230-1	1		10101817	DEB	001/20 #	EGGS LIQUID FRESH START WITH CITRIC ACID	20.00	34.83	CS	34.83
							___cs ___pk r m s d ck'd by ___				
							***** 02-COOLER *****				34.83
20	FE-159-1	1		206110	ADVANC	032/6 OZ	BEEF STK PHILLY PUCK STYLE STEAK EZE	12.00	9.46	#N	113.52
							___cs ___pk r m s d ck'd by ___				
30	FD-644-1	1		220025	SMITHE	001/15 #	BACON APPLEWOOD SMOKED 14/18 LAYOUT SILVER MEDAL	15.00	4.33	#N	64.95
							___cs ___pk r m s d ck'd by ___				
40	FE-224-1	1		224012	FARMLA	001/10 #	SAUSAGE PATTY 2oz BAGEL SIZE CKD SILVER LABEL	10.00	4.23	#N	42.30
							___cs ___pk r m s d ck'd by ___				
50	FH-594-2	1		290030	KRUSTE	072/2.5 OZ	FRENCH TOAST CINNAMON THICK	12.02	66.23	CS	66.23
							___cs ___pk r m s d ck'd by ___				
60	FI-125-1	1		318037	PILSBU	120/2 OZ	BISCUIT SOUTHERN STYLE BAKED	15.00	53.03	CS	53.03
							___cs ___pk r m s d ck'd by ___				
70	FC-157-2A	1		10092275	SWAGGE	004/5 #	SAUSAGE GRAVY COUNTRY STYLE	20.00	2.52	#N	50.40
							___cs ___pk r m s d ck'd by ___				
90	FF-592-2	1		10110960	TYSON	002/5 #	CHIX TENDER FRITTER HMESTYLE RTC NAE	10.00	36.91	CS	36.91
							___cs ___pk r m s d ck'd by ___				

TOTAL QTY. THIS PAGE	9	TERMS: BALANCE DUE UPON RECEIPT OF STATEMENT. PURCHASER IS RESPONSIBLE FOR SERVICE CHARGE OF 1-12% PER MONTH (18% PER YEAR) ON PAST DUE ACCOUNTS AND ALL COSTS OF COLLECTION INCLUDING ATTORNEY FEES REGARDLESS WHETHER SUIT IS INSTITUTED. PALM BEACH COUNTY IS EXCLUSIVE VENUE FOR SUITS REGARDING COLLECTION OF DELINQUENT ACCOUNT(S) AND THE SALE OF THE ABOVE GOODS.	RECEIVED BY: THE ABOVE LISTED MERCHANDISE HAS BEEN RECEIVED IN GOOD CONDITION, UNLESS OTHERWISE NOTED ON THE "DELIVERY COPY". CBI reserves the right to retake possession of products until all products and services are paid for in compliance with terms.	Estimated Total
TOTAL QTY. THIS INVOICE				CONTINUE

All values in US Dollars



ONE CHENEY WAY · PUNTA GORDA, FL 33982-4401
FOOD SERVICE DISTRIBUTORS

DELIVERING
Southern Hospitality
 SINCE 1923

#60432201

www.cheneybrothers.com

BILL TO:
 MIRA BAY CLUB
 HARBOR BAY CDD
 107 MANNS HARBOR DR
 APOLLO BEACH FL 33572 US

SHIP TO:
 MIRA BAY CLUB
 HARBOR BAY CDD
 107 MANNS HARBOR DR
 APOLLO BEACH FL 33572 US

DD RF
 DW 06:30-10:30
 (813) 649-1500

INVOICE NO.	PAGE	CLK	CH'D BY
06-929970007	2	MBL	
CUSTOMER NO.	TIME	MO.	DAY
60432201	18:21	01	29 26
TAX ID: 858012574204C8			

SPECIAL INSTRUCTIONS	TERMS	SALESPERSON	PUN	941.505.5885
	1 WK DUE	DUE: 02/05/2026	WATS	844.234.1341
	TR (WKY)	JILL COX 12391	FAX	941.505.5886
			P.O. NUMBER	ROUTE
			0	4005
				STOP
				12

LINE	LOCATION	CASES	PKGS.	ITEM NO.	BRAND	PACK/SIZE	DESCRIPTION	WEIGHT	UNIT PRICE	AMOUNT
100	FF-604-2A	1		10174747	SIMPL0	006/2.5 #	POTATO AND VEGETABLE ROASTED HASH	15.00	49.99	CS 49.99
		C.O.								
							__cs __pk r m s d ck'd by __			
							***** 03-FREEZER *****			477.33
01-DRY GOODS			39.89	02-COOLER		34.83	03-FREEZER			477.33

The perishable agricultural commodities listed on this invoice are sold subject to the statutory trust authorized by section 5(c) of the Perishable Agricultural Commodities Act, 1930 (7 U.S.C. 499e(c)). The seller of these commodities retains a trust claim over these commodities, all inventories of food or other products derived from these commodities, and any receivables or proceeds from the sale of these commodities until full payment is received. Reel Fresh product noted with "Refresh" on the invoice has been thawed from previously frozen product. Cert # FL-2033-SS Wholesale # WD-7867



TOTAL QTY. THIS PAGE	1	TERMS: BALANCE DUE UPON RECEIPT OF STATEMENT. PURCHASER IS RESPONSIBLE FOR SERVICE CHARGE OF 1-12% PER MONTH (18% PER YEAR) ON PAST DUE ACCOUNTS AND ALL COSTS OF COLLECTION, INCLUDING ATTORNEY FEES REGARDLESS WHETHER SUIT IS INSTITUTED. PALM BEACH COUNTY IS EXCLUSIVE VENUE FOR SUITS REGARDING COLLECTION OF DELINQUENT ACCOUNT(S) AND THE SALE OF THE ABOVE GOODS.	RECEIVED BY:	153.82	Estimated Total
TOTAL QTY. THIS INVOICE	10				\$ 552.05

All values in US Dollars



ONE CHENEY WAY - PUNTA GORDA, FL 33982-4401
FOOD SERVICE DISTRIBUTORS

DELIVERING
Southern Hospitality
 SINCE 1989

#60432201

www.cheneybrothers.com

BILL TO:
 MIRA BAY CLUB
 HARBOR BAY CDD
 107 MANNS HARBOR DR
 APOLLO BEACH FL 33572 US

SHIP TO:
 MIRA BAY CLUB
 HARBOR BAY CDD
 107 MANNS HARBOR DR
 APOLLO BEACH FL 33572 US

DD RF
 DW 06:30-10:30
 (813) 649-1500

INVOICE NO.	PAGE	CLK	CH'D BY
06-929970016	1	LAP	
CUSTOMER NO.	TIME	MO.	DAY YR.
60432201	18:22	01	29 26
TAX ID: 858012574204C8			

SPECIAL INSTRUCTIONS	TERMS	SALESPERSON	PUN 941.505.5885	P.O. NUMBER	ROUTE	STOP
	1 WK DUE	DUE: 02/05/2026	WATS 844.234.1341	1	4005	12
	TR (WKY)	JILL COX 12391	FAX 941.505.5886			

LINE	LOCATION	CASES	PKGS.	ITEM NO.	BRAND	PACK/SIZE	DESCRIPTION	WEIGHT	UNIT PRICE	AMOUNT
10	DF-641-1	1		116045	WESSON	003/1 GAL	BUTTER LIQUID SUB BEYOND BUTTER WESSON PRO PERFORMANCE BUTTER ALT.	24.80	39.89	CS 39.89
							___cs ___pk r m s d ck'd by ___			
							***** 01-DRY GOODS *****			39.89
20	FE-224-1	2		224012	FARMLA	001/10 #	SAUSAGE PATTY 2oz BAGEL SIZE CKD SILVER LABEL	20.00	4.23	#N 84.60
							___cs ___pk r m s d ck'd by ___			
							***** 03-FREEZER *****			84.60

01-DRY GOODS 39.89 03-FREEZER 84.60

The perishable agricultural commodities listed on this invoice are sold subject to the statutory trust authorized by section 5(c) of the Perishable Agricultural Commodities Act, 1930 (7 U.S.C. 499e(c)). The seller of these commodities retains a trust claim over these commodities, all inventories of food or other products derived from these commodities, and any receivables or proceeds from the sale of these commodities until full payment is received. Reel Fresh product noted with "Refresh" on the invoice has been thawed from previously frozen product. Cert # FL-2033-SS Wholesale # WD-7867



929970016

TOTAL QTY. THIS PAGE	3	TERMS: BALANCE DUE UPON RECEIPT OF STATEMENT. PURCHASER IS RESPONSIBLE FOR SERVICE CHARGE OF 1-10% PER MONTH (18% PER YEAR) ON PAST DUE ACCOUNTS AND ALL COSTS OF COLLECTION, INCLUDING ATTORNEY FEES REGARDLESS WHETHER SUIT IS INSTITUTED. PALM BEACH COUNTY IS EXCLUSIVE VENUE FOR SUITS REGARDING COLLECTION OF DELINQUENT ACCOUNT(S) AND THE SALE OF THE ABOVE GOODS.	RECEIVED BY	44.80	Estimated Total
TOTAL QTY. THIS INVOICE	3				\$ 124.49

All values in US Dollars



ONE CHENEY WAY • PUNTA GORDA, FL 33982-4401
FOOD SERVICE DISTRIBUTORS

DELIVERING
Southern Hospitality
 SINCE 1988

#60432201

www.cheneybrothers.com

BILL TO:
 MIRA BAY CLUB
 HARBOR BAY CDD
 107 MANNS HARBOR DR
 APOLLO BEACH FL 33572 US

SHIP TO:
 MIRA BAY CLUB
 HARBOR BAY CDD
 107 MANNS HARBOR DR
 APOLLO BEACH FL 33572 US

DD RF
 DW 06:30-10:30
 (813) 649-1500

INVOICE NO.	PAGE	CLK	CH'D BY
06-929970426	1	DGO	
CUSTOMER NO.	TIME	MO.	DAY YR.
60432201	19:10	01	29 26

TAX ID: 858012574204C8

SPECIAL INSTRUCTIONS	TERMS	SALESPERSON	PUN 941.505.5885	P.O. NUMBER	ROUTE	STOP
	1 WK DUE	DUE: 02/05/2026	WATS 844.234.1341		4005	12
	TR (WKY)	JILL COX 12391	FAX 941.505.5886			

LINE	LOCATION	CASES	PKGS.	ITEM NO.	BRAND	PACK/SIZE	DESCRIPTION	WEIGHT	UNIT PRICE	AMOUNT
10	FY-091-35	1		10157036	HOOD	002/2.5 GAL	MIX ICE CREAM CHOCOLATE 10%	47.60	72.98	CS 72.98
		C.O.								
							_____cs _____pk r m s d ck'd by _____			
							***** 03-FREEZER *****			72.98

03-FREEZER 72.98

The perishable agricultural commodities listed on this invoice are sold subject to the statutory trust authorized by section 5(c) of the Perishable Agricultural Commodities Act, 1930 (7 U.S.C. 499e(c)). The seller of these commodities retains a trust claim over these commodities, all inventories of food or other products derived from these commodities, and any receivables or proceeds from the sale of these commodities until full payment is received. Reel Fresh product noted with "Refresh" on the invoice has been thawed from previously frozen product. Cert # FL-2033-SS Wholesale # WD-7867



929970426

52000-4842 → 461.14 → Total - 749.82
 52000-3122 → 288.64

TOTAL QTY. THIS PAGE	1	TERMS: BALANCE DUE UPON RECEIPT OF STATEMENT. PURCHASER IS RESPONSIBLE FOR SERVICE CHARGE OF 1-12% PER MONTH (18% PER YEAR) ON PAST DUE ACCOUNTS AND ALL COSTS OF COLLECTION, INCLUDING ATTORNEY FEES REGARDLESS WHETHER SUIT IS INSTITUTED. PALM BEACH COUNTY IS EXCLUSIVE VENUE FOR SUITS REGARDING COLLECTION OF DELINQUENT ACCOUNTS, AND THE SALE OF THE ABOVE GOODS.	RECEIVED BY:	47.60	Estimated Total
TOTAL QTY. THIS INVOICE	1		THE ABOVE LISTED MERCHANDISE HAS BEEN RECEIVED IN GOOD CONDITION UNLESS OTHERWISE NOTED ON THE DELIVERY COPY. CBI reserves the right to retake possession of products until all products and services are paid for in compliance with terms.		\$ 72.98

All values in US Dollars



REMIT PAYMENT TO:
 CINTAS CORP
 P.O. BOX 630910
 CINCINNATI, OH 45263-0910

PAY YOUR BILL WITH MYCINTAS
 WWW.CINTAS.COM/MYACCOUNT
 MANAGE | SHOP | PAY

CUSTOMER SVC/BILLING 833-290-0514
 CINTAS FAX # 813-626-8852
 PAYMENT INQUIRY 813-644-8357

INVOICE

SHIP TO: HARBOR BAY CDD
 107 HANNS HARBOR DR
 APOLLO BEACH, FL 33572-3340

INVOICE # 1906120137
 INVOICE DATE 01/29/2023
 CUSTOMER REF # HARBOR BAY COMMUNITY DEVELOPMENT

BILL TO: HARBOR BAY CDD
 107 HANNS HARBOR DR
 APOLLO BEACH, FL 33572-3340

SOLD TO # 19475047
 PAYER # 19475047
 PAYMENT TERMS NET 10 EOM
 SORT # 00740015433
 CINTAS ROUTE 76 / DAY 4 / STOP 008

EMP#/LOCK#	MATERIAL	DESCRIPTION	FREQ	EXCH	QTY	UNIT PRICE	LINE TOTAL	TAX
	452030000	SANIT HAND WCM/723X17X4/SBPT+	6		2	160.000	320.00	0
		SUBTOTAL					320.00	
		SUBTOTAL					320.00	
		TAX					(0.00)	
		TOTAL USD					320.00	

TOTAL ADJUST. _____
 TAX ADJUST. _____
 NET TOTAL _____

52800-4519



REMIT PAYMENT TO:
 CINTAS CORP
 P.O. BOX 630910
 CINCINNATI, OH 45263-0910

PAY YOUR BILL WITH MYCINTAS
 WWW.CINTAS.COM/MYACCOUNT
 MANAGE | SHOP | PAY

CUSTOMER SVC/BILLING 833-290-0514
 CINTAS FAX # 813-626-8852
 PAYMENT INQUIRY 813-644-8357

INVOICE

SHIP TO: HARBOR BAY CDD
 107 MANNS HARBOR DR
 APOLLO BEACH, FL 33572-3340

INVOICE # 1906049016
INVOICE DATE 12/22/2025
SERVICE TICKET # 9351865075
CUSTOMER REF # HARBOR BAY
 COMMUNITY
 DEVELOPMENT

BILL TO: HARBOR BAY CDD
 107 MANNS HARBOR DR
 APOLLO BEACH, FL 33572-3340

SOLD TO # 13475047
PAYER # 13475047
PAYMENT TERMS NET 10 EOM
SORT # 00740015438
CINTAS ROUTE 76 / DAY 4 / STOP 008

EMP#/LOCK#	MATERIAL	DESCRIPTION	FREQ	EXCH	QTY	UNIT PRICE	LINE TOTAL	TAX
	452030000	SANIT HAND WIPE/23X10X4/50CT-		D	8	40.000	320.00	N
							SUBTOTAL	320.00
		SUBTOTAL						320.00
		TAX						0.00
		TOTAL USD						320.00



REMIT PAYMENT TO:
 CINTAS CORP
 P.O. BOX 630910
 CINCINNATI, OH 45263-0910

PAY YOUR BILL WITH MYCINTAS
 WWW.CINTAS.COM/MYACCOUNT
 MANAGE | SHOP | PAY

CUSTOMER SVC/BILLING 833-290-0514
 CINTAS FAX # 813-626-8852
 PAYMENT INQUIRY 813-644-8357

INVOICE

SHIP TO: HARBOR BAY CDD
 107 MANNS HARBOR DR
 APOLLO BEACH, FL 33572-3340

INVOICE # 4254382338
INVOICE DATE 12/26/2025
SERVICE TICKET # 4254382338
CUSTOMER REF # HARBOR BAY
 COMMUNITY
 DEVELOPMENT

BILL TO: HARBOR BAY CDD
 107 MANNS HARBOR DR
 APOLLO BEACH, FL 33572-3340

SOLD TO # 13475047
PAYER # 13475047
PAYMENT TERMS NET 10 EOM
SORT # 00740015438
CINTAS ROUTE 76 / DAY 4 / STOP 008

DEPT: DEPT 1

EMP#/LOCK#	MATERIAL	DESCRIPTION	FREQ	EXCH	QTY	UNIT PRICE	LINE TOTAL	TAX
	X10186	4X6 ACTIVE SCRAPER	01	F	2	12.466	24.93	N
	X27000	SIG ZFOLD DSP ALU-	01	F	10	0.000	0.00	N
	X27006	SIG ZFOLD CVR BLUE-	01	F	10	0.000	0.00	N
	X27012	SIG ZFOLD RFL PAPER/CS-	01	F	4	60.280	241.12	N
	X27071	SIG DUALTP DSP ALU-	01	F	30	0.000	0.00	N
	X27077	SIG DUALTP CVR BLUE-	01	F	30	0.000	0.00	N
	X27083	SIG DUALTP RFL PAPER/CS-	01	F	2	33.761	67.52	N
	X7190	DISP RESTROOM MAT SVC	01	F	5	3.800	19.00	N
	X7515	SANIS COMMODE MAT-	01	F	12	5.346	64.15	N
DEPT 1 SUBTOTAL							416.72	



REMIT PAYMENT TO:
 CINTAS CORP
 P.O. BOX 630910
 CINCINNATI, OH 45263-0910

INVOICE # 4254382338
 INVOICE DATE 12/26/2025
 SERVICE TICKET # 4254382338

INVOICE

DEPT: DEPT 2

EMP#/LOCK#	MATERIAL	DESCRIPTION	FREQ	EXCH	QTY	UNIT PRICE	LINE TOTAL	TAX
	X2272	FC4 NEUTRAL FLR CLNR-	01	F	10	3.541	35.41	N
	X2274	FC2 BIO BASE FL CLNR-	01	F	5	4.813	24.07	N
	X2275	GL1 GLASS&SURF CLNR-	04	F	2	6.832	13.66	N
	X2276	RR1 DISINFCT/ RR CLNR-	04	F	2	9.709	19.42	N
	X2278	SIGNET SK1 DETERGENT-	01	F	7	3.004	21.03	N
	X2279	SK2 SINK SANITIZER-	01	F	7	3.108	21.76	N
	X2280	Z1 HARD SURF SANITZR-	01	F	25	10.386	259.65	N
	X2281	DG1 HD FOAM DEGRSR-	04	F	1	5.178	5.18	N
	X27014	SIG AIR DSP DRK-	01	F	10	0.000	0.00	N
	X27058	SIG SOAP DSP ALU-	01	F	14	0.000	0.00	N
	X27064	SIG SOAP CVR BLUE-	01	F	14	0.000	0.00	N
	X27069	SIG SOAP SVC	01	F	14	7.848	109.87	N
	X27070	SIG SOAP RFL FOAM-	04	F	14	0.000	0.00	N
	X45690	B&V AIR CARE COUNTER DISP WHT-	01	F	12	8.844	106.13	N
	X7000	20"MICROFIBER MOP BL-	01	F	10	2.679	26.79	N
	X7500	CLEANING CHEM DISP-	01	F	2	4.103	8.21	N
	X8020	MICRFBR TUBE MOP-	01	F	2	3.023	6.05	N
	X9312	1000 MOISTURE SP SVC	01	F	4	10.495	41.98	N
	X9313	1000 MOISTURE SOAP REFILL-	04	F	4	0.000	0.00	N
	X9322	INST HAND SANT SVC	01	F	6	8.470	50.82	N
	X9323	INST HAND SANT GEL RFL-	04	F	6	0.000	0.00	N
	X9980	SANIS SOAP DISPENSER WHITE-	01	F	6	0.000	0.00	N
	X9980	SANIS SOAP DISPENSER WHITE-	04	F	4	0.000	0.00	N
		DEPT 2 SUBTOTAL					750.03	
		SERVICE CHARGE					16.92	N
		SUBTOTAL					1183.67	
		TAX					0.00	
		TOTAL USD					1183.67	

Signature :





REMIT PAYMENT TO:
 CINTAS CORP
 P.O. BOX 630910
 CINCINNATI, OH 45263-0910

PAY YOUR BILL WITH MYCINTAS
 WWW.CINTAS.COM/MYACCOUNT
 MANAGE | SHOP | PAY

CUSTOMER SVC/BILLING 833-290-0514
 CINTAS FAX # 813-626-8852
 PAYMENT INQUIRY 813-644-8357

INVOICE

SHIP TO: HARBOR BAY CDD
 107 MANNS HARBOR DR
 APOLLO BEACH, FL 33572-3340

INVOICE # 4256455380
INVOICE DATE 01/15/2026
SERVICE TICKET # 4256455380
CUSTOMER REF # HARBOR BAY
 COMMUNITY
 DEVELOPMENT

BILL TO: HARBOR BAY CDD
 107 MANNS HARBOR DR
 APOLLO BEACH, FL 33572-3340

SOLD TO # 13475047
PAYER # 13475047
PAYMENT TERMS NET 10 EOM
SORT # 00740015438
CINTAS ROUTE 76 / DAY 4 / STOP 008

DEPT: DEPT 1

EMP#/LOCK#	MATERIAL	DESCRIPTION	FREQ	EXCH	QTY	UNIT PRICE	LINE TOTAL	TAX
	X10186	4X6 ACTIVE SCRAPER	01	F	2	12.466	24.93	N
	X27000	SIG ZFOLD DSP ALU-	01	F	10	0.000	0.00	N
	X27006	SIG ZFOLD CVR BLUE-	01	F	10	0.000	0.00	N
	X27012	SIG ZFOLD RFL PAPER/CS-	01	F	4	60.280	241.12	N
	X27071	SIG DUALTP DSP ALU-	01	F	30	0.000	0.00	N
	X27077	SIG DUALTP CVR BLUE-	01	F	30	0.000	0.00	N
	X27083	SIG DUALTP RFL PAPER/CS-	01	F	2	33.761	67.52	N
	X6680	DISP URINAL MAT SVC	04	F	3	22.280	66.84	N
	X7190	DISP RESTROOM MAT SVC	01	F	5	3.800	19.00	N
	X7191	DISP RESTROOM MAT RFL-	04	F	5	0.000	0.00	N
	X7463	DISP COMMODE MAT RFL-	04	F	12	0.000	0.00	N
	X7464	DISP URINAL MAT RFL-	04	F	3	0.000	0.00	N
	X7515	SANIS COMMODE MAT-	01	F	12	5.346	64.15	N
DEPT 1 SUBTOTAL							483.56	



REMIT PAYMENT TO:
 CINTAS CORP
 P.O. BOX 630910
 CINCINNATI, OH 45263-0910

INVOICE # 4256455380
 INVOICE DATE 01/15/2026
 SERVICE TICKET # 4256455380

INVOICE

DEPT: DEPT 2

EMP#/LOCK#	MATERIAL	DESCRIPTION	FREQ	EXCH	QTY	UNIT PRICE	LINE TOTAL	TAX
	X2272	FC4 NEUTRAL FLR CLNR-	01	F	10	3.541	35.41	N
	X2274	FC2 BIO BASE FL CLNR-	01	F	5	4.813	24.07	N
	X2278	SIGNET SK1 DETERGENT-	01	F	7	3.004	21.03	N
	X2279	SK2 SINK SANITIZER-	01	F	7	3.108	21.76	N
	X2280	Z1 HARD SURF SANITZR-	01	F	25	10.386	259.65	N
	X27014	SIG AIR DSP DRK-	01	F	10	0.000	0.00	N
	X27058	SIG SOAP DSP ALU-	01	F	14	0.000	0.00	N
	X27064	SIG SOAP CVR BLUE-	01	F	14	0.000	0.00	N
	X27069	SIG SOAP SVC	01	F	14	7.848	109.87	N
	X45690	B&V AIR CARE COUNTER DISP WHT-	01	F	12	8.844	106.13	N
	X7000	20"MICROFIBER MOP BL-	01	F	10	2.679	26.79	N
	X7500	CLEANING CHEM DISP-	01	F	2	4.103	8.21	N
	X8020	MICRFBR TUBE MOP-	01	F	2	3.023	6.05	N
	X9312	1000 MOISTURE SP SVC	01	F	4	10.495	41.98	N
	X9322	INST HAND SANT SVC	01	F	6	8.470	50.82	N
	X9980	SANIS SOAP DISPENSER WHITE-	01	F	6	0.000	0.00	N
DEPT 2 SUBTOTAL							711.77	
SERVICE CHARGE								16.92 N
SUBTOTAL								1212.25
TAX								0.00
TOTAL USD								1212.25

Signature :

Cust. Name: HARBOR BAY CDD
 tony ramos 12:28 PM 01/15/26
SoldTo# 0013475047 **SO# 4256455380**
 Invoice Total Payment on Account
\$1,212.25 \$0.00

TR



REMIT PAYMENT TO: PAY YOUR BILL WITH MYCINTAS
 CINTAS CORP
 P.O. BOX 630910
 CINCINNATI, OH 45263-0910
 WWW.CINTAS.COM/MYACCOUNT
 MANAGE | SHOP | PAY

CUSTOMER SVC/BILLING 833-290-0514
CINTAS FAX # 813-626-8852
PAYMENT INQUIRY 813-644-8357

INVOICE

SHIP TO: HARBOR BAY CDD
 107 MANNS HARBOR DR
 APOLLO BEACH, FL 33572-3340

INVOICE # 4257978117
INVOICE DATE 01/29/2026
CUSTOMER REF # HARBOR BAY COMMUNITY DEVELOPMENT

BILL TO: HARBOR BAY CDD
 107 MANNS HARBOR DR
 APOLLO BEACH, FL 33572-3340

SOLD TO # 13475047
PAYER # 13475047
PAYMENT TERMS NET 10 EOM
SORT # 00740015438
CINTAS ROUTE 76 / DAY 4 / STOP 008

DEPT: DEPT 1

EMP#/LDCK#	MATERIAL	DESCRIPTION	FREQ	EXCH	QTY	UNIT PRICE	LINE TOTAL	TAX
	X10186	4X6 ACTIVE SCRAPER	01	F	2	12.466	24.93	N
	X27000	SIG ZFOLD DSP ALU-	01	F	10	0.000	0.00	N
	X27006	SIG ZFOLD CVR BLUE-	01	F	10	0.000	0.00	N
	X27012	SIG ZFOLD RFL PAPER/CS-	01	F	4	60.280	241.12	N
	X27071	SIG DUALTP DSP ALU-	01	F	30	0.000	0.00	N
	X27077	SIG DUALTP CVR BLUE-	01	F	30	0.000	0.00	N
	X27083	SIG DUALTP RFL PAPER/CS-	01	F	2	33.761	67.52	N
	X7190	DISP RESTROOM MAT SVC	01	F	5	3.800	19.00	N
	X7515	SANIS COMMODE MAT-	01	F	12	5.346	64.15	N
DEPT 1 SUBTOTAL							416.72	



REMIT PAYMENT TO:
 CINTAS CORP
 P.O. BOX 630910
 CINCINNATI, OH 45263-0910

INVOICE # 4257978117
INVOICE DATE 01/29/2026

INVOICE

DEPT: DEPT 2

EMP#/LOCK#	MATERIAL	DESCRIPTION	FREQ	EXCH	QTY	UNIT PRICE	LINE TOTAL	TAX
X2272		FC4 NEUTRAL FLR CLNR-	01	F	10	3.541	35.41	N
X2274		FC2 RID BASE FL CLNR-	01	F	5	4.813	24.07	N
X2278		SIGNET SKI DETERGENT-	01	F	7	3.004	21.03	N
X2279		SK2 SINK SANITIZER-	01	F	7	3.108	21.76	N
X2280		Z1 HARD SURF SANITZR-	01	F	25	10.386	259.65	N
X27014		SIG AIR DSP DRK-	01	F	10	0.000	0.00	N
X27058		SIG SOAP DSP ALU-	01	F	14	0.000	0.00	N
X27064		SIG SOAP CVR BLUE-	01	F	14	0.000	0.00	N
X27069		SIG SOAP SVC	01	F	14	7.846	109.87	N
X45690		B&V AIR CARE COUNTER DISP WHT-	01	F	12	8.844	106.13	N
X7000		20"MICROFIBER ROP BL-	01	F	10	2.679	26.79	N
X7500		CLEANING CHEM DISP-	01	F	2	4.103	8.21	N
X8020		MICRFBR TUBE ROP-	01	F	2	3.023	6.05	N
X9312		1000 MOISTURE SP SVC	01	F	4	10.495	41.98	N
X9322		INST HAND SANT SVC	01	F	6	8.470	50.82	N
X9980		SANIS SOAP DISPENSER WHITE-	01	F	4	0.000	0.00	N
DEPT 2 SUBTOTAL							711.77	
SERVICE CHARGE							16.92	N
SUBTOTAL							1145.41	
TAX							(0.00)	
TOTAL USD							1145.41	

TOTAL ADJUST. _____
TAX ADJUST. _____
NET TOTAL _____

52800-4519

CUSTOMER TOTAL CURRENT: 2382.26 PAST DUE: 1086.95 30 DAYS: 0.00 60 DAYS: 0.00 90+ DAYS: 0.00



SEND PAYMENT TO: PAY YOUR BILL WITH MYCINTAS
 CINTAS CORP WWW.CINTAS.COM/MYACCOUNT
 P.O. BOX 430910 MANAGE | SHOP | PAY
 CINCINNATI, OH 45243-0910

CUSTOMER SVC/BILLING 833-290-0514
 CINTAS FAX # 813-626-8852
 PAYMENT INQUIRY 813-644-8357

INVOICE

SHIP TO: HARBOR BAY CDD
 107 HANNS HARBOR DR
 APOLLO BEACH, FL 33572-3340

INVOICE # 9250726188
INVOICE DATE 07/05/2026
CUSTOMER REF # HARBOR BAY COMMUNITY DEVELOPMENT

BILL TO: HARBOR BAY CDD
 107 HANNS HARBOR DR
 APOLLO BEACH, FL 33572-3340

SOLD TO # 13475047
PAYER # 13475047
PAYMENT TERMS NET 10 EOM
SOFT # 00740015438
CINTAS ROUTE TS / DAY 4 / STOP 000

DEPT: DEPT 1

EMP#/LOCK#	MATERIAL	DESCRIPTION	FREQ	EXCH	QTY	UNIT PRICE	LINE TOTAL	TAX
	X10186	4X6 ACTIVE SCRAPER	01	F	2	12.468	24.93	N
	X27000	SIG ZFOLD DSP ALU-	01	F	10	0.000	0.00	N
	X27006	SIG ZFOLD CUR BLUE-	01	F	10	0.000	0.00	N
	X27012	SIG ZFOLD RFL PAPER/CS-	01	F	4	40.280	161.12	N
	X27071	SIG DUALTP DSP ALU-	01	F	30	0.000	0.00	N
	X27077	SIG DUALTP CUR BLUE-	01	F	30	0.000	0.00	N
	X27083	SIG DUALTP RFL PAPER/CS-	01	F	2	39.761	87.52	N
	X7190	DISP RESTROOM MAT SVC	01	F	5	3.800	19.00	N
	X7515	SANIS COMMODE MAT-	01	F	12	5.348	64.18	N
DEPT 1 SUBTOTAL							416.73	

52800-4519



REMIT PAYMENT TO:
 CINTAS CORP
 P.O. BOX 630910
 CINCINNATI, OH 45263-0910

INVOICE # 4253726188
 INVOICE DATE 02/05/2026

INVOICE

DEPT: DEPT 2

EMP#/LOCK#	MATERIAL	DESCRIPTION	FRCA	EXCH	QTY	UNIT PRICE	LINE TOTAL	TAX
	X2272	FC4 NEUTRAL FLR CLR-	01		10	3.541	35.41	N
	X2274	FC2 BLD BASE FL CLR-	01	F	5	4.833	24.07	N
	X2278	SIGMET SKI DETERGENT-	01	F	7	3.069	21.03	N
	X2279	SK2 SINK SANITIZER-	01	F	7	3.108	21.76	N
	X2280	Z1 HARD SURF SANITZER-	01	F	25	10.366	259.15	N
	X27014	SIG AIR DSP BRK-	01	F	10	0.000	0.00	N
	X27058	SIG SOAP DSP BLU-	01	F	10	0.000	0.00	N
	X27064	SIG SOAP CBR BLUE-	01	F	10	0.000	0.00	N
	X27069	SIG SOAP SVC	01	F	14	7.848	109.87	N
	X45690	R&V AIR CARE COUNTER DISP WPI	01	F	12	8.847	106.13	N
	X7000	20"MICROFIBER MOP BL-	01	F	10	2.677	26.79	N
	X7500	CLEANING CHEM ATSP-	01	F	2	4.103	8.21	N
	X8020	MICROFIBER TUBE MOP-	01	F	2	3.023	6.05	N
	X9312	1000 MOISTURE SP SVC	01	F	4	10.495	41.98	N
	X9322	INST HAND SAHT SVC	01	F	6	8.470	50.82	N
	X9980	SANIS SOAP DISPENSER WHITE-	01	F	8	0.000	0.00	N
		DEPT 2 SUBTOTAL					711.77	
		SERVICE CHARGE					16.92	N
		SUBTOTAL					1145.41	
		TAX					(0.00)	
		TOTAL USD					1145.41	

52800 - 4519

TOTAL ADJUST. _____
 TAX ADJUST. _____
 NET TOTAL _____

CUSTOMER DIAL CURRENT: 4167 67 PAST DUE 1086 95 30 DAYS: 0.00 60 DAYS: 0.00 90 DAYS: 0.00



REMIT PAYMENT TO: PAY YOUR BILL WITH MYCINTAS
 CINTAS CORP
 P.O. BOX 430910
 CINCINNATI, OH 45263-0910

WWW.CINTAS.COM/MYACCOUNT
 MANAGE | SHOP | PAY

CUSTOMER SVC/BILLING 833-290-0514
CINTAS FAX # 813-626-8852
PAYMENT INQUIRY 813-644-8357

INVOICE

SHIP TO: HARBOR BAY CDD
 107 HANNS HARBOR DR
 APOLLO BEACH, FL 33572-3340

INVOICE # 4259493913
INVOICE DATE 02/12/2026
CUSTOMER REF # HARBOR BAY COMMUNITY DEVELOPMENT

BILL TO: HARBOR BAY CDD
 107 HANNS HARBOR DR
 APOLLO BEACH, FL 33572-3340

SOLD TO # 13475047
PAYER # 13475047
PAYMENT TERMS NET 10 EOM
SORT # 00740015438
CINTAS ROUTE 76 / DAY 4 / STOP 008

DEPT: DEPT 1

EMP#/LOCK#	MATERIAL	DESCRIPTION	FREQ	EXCH	QTY	UNIT PRICE	LINE TOTAL	TAX
	X10186	4X6 ACTIVE SCRAPER	01	F	2	12.466	24.93	N
	X27000	SIG ZFOLD DSP ALU-	01	F	10	0.000	0.00	N
	X27006	SIG ZFOLD CUR BLUE-	01	F	10	0.000	0.00	N
	X27012	SIG ZFOLD RFL PAPER/CS-	01	F	4	60.280	241.12	N
	X27071	SIG DUALTP DSP ALU-	01	F	30	0.000	0.00	N
	X27077	SIG DUALTP CUR BLUE-	01	F	30	0.000	0.00	N
	X27083	SIG DUALTP RFL PAPER/CS-	01	F	2	33.761	67.52	N
	X6680	DISP URINAL MAT SUC	04	F	3	22.280	66.84	N
	X7190	DISP RESTROOM MAT SUC	01	F	5	3.600	18.00	N
	X7191	DISP RESTROOM MAT RFL-	04	F	5	0.000	0.00	N
	X7463	DISP COMMDE MAT RFL-	04	F	12	0.000	0.00	N
	X7464	DISP URINAL MAT RFL-	04	F	3	0.000	0.00	N
	X7515	SANIS COMMDE MAT-	01	F	12	5.346	64.15	N
DEPT 1 SUBTOTAL							483.56	

52800-4519



REMIT PAYMENT TO:
 CINTAS CORP
 P.O. BOX 630910
 CINCINNATI, OH 45263-0910

INVOICE # 4259493913
 INVOICE DATE 02/12/2026

INVOICE

DEPT: DEPT 2

EMP#/LOCK#	MATERIAL	DESCRIPTION	FREQ	EXCH	QTY	UNIT PRICE	LINE TOTAL	TAX
	X2272	FC4 NEUTRAL FLR CLNR-	01	F	10	3.541	35.41	N
	X2274	FC2 BIO BASE FL CLNR-	01	F	5	4.813	24.07	N
	X2278	SIGNET SK1 DETERGENT-	01	F	7	3.004	21.03	N
	X2279	SK2 SINK SANITIZER-	01	F	7	3.108	21.76	N
	X2280	Z1 HARD SURF SANITZR-	01	F	25	10.386	259.65	N
	X27014	SIG AIR DSP DRK-	01	F	10	0.000	0.00	N
	X27058	SIG SOAP DSP ALU-	01	F	14	0.000	0.00	N
	X27064	SIG SOAP CUR BLUE-	01	F	14	0.000	0.00	N
	X27069	SIG SOAP SUC	01	F	14	7.848	109.87	N
	X45690	B&V AIR CARE COUNTER DISP WHY-	01	F	12	8.844	106.13	N
	X7000	20"MICROFIBER MOP BL-	01	F	10	2.679	26.79	N
	X7500	CLEANING CHEM DISP-	01	F	2	4.103	8.21	N
	X8020	MICROFIBR TUBE MOP-	01	F	2	3.023	6.05	N
	X9312	1000 MOISTURE SF SUC	01	F	4	10.495	41.98	N
	X9322	INST HAND SANT SUC	01	F	6	8.470	50.82	N
	X9980	SANIS SOAP DISPENSER WHITE-	01	F	6	0.000	0.00	N
		DEPT 2 SUBTOTAL					711.77	
		SERVICE CHARGE					16.92	N
		SUBTOTAL					1212.25	
		TAX					(0.00)	
		TOTAL USD					1212.25	

TOTAL ADJUST. _____
 TAX ADJUST. _____
 NET TOTAL _____

52800-4519

CUSTOMER TOTAL CURRENT: 2997.66 PAST DUE: 0.00 30 DAYS: 1086.95 60 DAYS: 0.00 90+ DAYS: 0.00

FOR ALL NON-PAYMENT RELATED CORRESPONDENCE : CINTAS CORPORATION 80074 / 7101 PARK EAST BLVD. / TAMPA, FL 33610

CUSTOMER SERVICE 1-844-863-2653



50775647013
INVOICE

PAYER:CAFE AT MIRA BAY

SHIP TO:

CAFE AT MIRA BAY

MIRABAY HOA INC

107 MANN'S HARBOR DR

APOLLO BEACH, FL 33572-3340

REMIT TO:

Coca-Cola Beverages Florida LLC

PO Box: 740909

Atlanta, GA 30374-0909

OUTLET 500130057 INV# 50775647013
STORE# VENDOR#

PO# DSD#
SHP# 50775647 DRV# 899013604 Brent Blas
RTE# I032RD1 PLT# I032
VHL# 200406586 TRL# 200406563
DEL/ASN# 3282640295 DEL DATE: 01/27/2026 11:02:45 AM

SALES

DESCRIPTION	MAT#	QTY	PRICE	CON#	RATE	NET	EXTENDED
SPARKLIN 5GA 1-Ls							
		1/1					139.24
5GBIB COKE	103936	1	139.24		0.00	139.24	139.24
049000981025	1						

DELIVERY RECAP

SPARKLIN 5GA 1-Ls 1/1

NET PRODUCT QTY 1
NET SINGLES QTY 0
NET CONSUMER QTY 1

TOTAL PRODUCTS 139.24

AMOUNT DUE 139.24
AMOUNT PAID 0.00

TERMS Net 15

PERFORMANCE INVOICE

DATE

2/2/26

INVOICE NO

2

David Nichols

5004 Wild Senna Blvd
Tampa FL 33619

Phone 910- 257-5480

INVOICE TO

Harbor Bay CCD
C/o Rizzetta & Company
3434 Colwell Avenue, Suite 200
Tampa, Florida 33614

Description

David Nichols performed song selections on saxophone for The
Mirabay Club

Dates and time of performance(s)

*Performance 1. Friday February 13, 2026, from 6pm-9pm
(3hours)

Fee agreed upon

\$500 (five hundred dollars)/ per performance
*NET 30

Bill to

Harbor Bay CCD
C/o Rizzetta & Company
3434 Colwell Avenue, Suite 200
Tampa, Florida 33614

Pay to the order of: David Nichols

Total Amount due: 500



REMIT TO:
 DECONNA ICE CREAM
 6300 W Hwy 318
 Reddick, FL 32686
 (352) 591-1530

Invoice	
NUMBER	DEL DATE
INV00418486	1/8/2026
ORDER NUMBER	ORD DATE
TP2489434	1/6/2026
INVOICE DUE: 1/8/2026	
TERMS:	Check

Ship To:

The Mirabay Club
 107 Manns Harbor Drive
 Apollo Beach, FL 33572
 (813)649-1500-Extn.0000

CORRESPONDENCE TO:

Tampa
 4605 N. Clark Avenue
 Tampa, FL 33614

Bill To:

The Mirabay Club
 Roxanae Benton
 107 Manns Harbor Drive
 Apollo Beach, FL 33572
 Hillsborough

CUSTOMER NUMBER	PO ORDER NUMBER	SALESPERSON ID	SHIPPING METHOD	DELIVERY DATE	ROUTE
THEMIRABAYCLUB		Mark Bishop	LOCAL DELIVERY	1/8/2026	TP-F-7A
CUSTOMER CLASS ID			DRIVER	REFERENCE NUMBER	
FRZR-TAMPA	TAMPA		Reggie Hearn	0	

ITEM NUMBER	UPC	DESCRIPTION	U OF M	ORDERED	SHIPPED	UNIT PRICE	EXT PRICE
DOV002	467737690	1-12 Dove Bar Almond		Box	1 1	29.40	29.40
DOV001	4767737681	1-12 Dove Bar Milk Chocolate		Box	1 1	29.40	29.40
DOV015	4767737688	1-12 Dove Bar Original - Vanilla/Dark Chocolate		Box	1 1	29.40	29.40
DEC057	1848924259	1-12 Fruit Bar Mango - DeConna (6/case)		Box	1 1	24.00	24.00
DEC050	1848924272	1-12 Fruit Bar Strawberry - DeConna (6/case)		Box	1 1	24.00	24.00
DEC124	1848924246	1-12 Gator Tracks Cone 8oz		Box	0 0	33.60	0.00
DOV016	4767748255	1-12 Starburst Strawberry Sorbet Bar 2.6oz		Box	1 1	19.20	19.20
DEC117	1848924203	1-12 Sundae Classic Chocolate 6oz Cup		Box	1 1	29.40	29.40
DEC115	1848924202	1-12 Sundae Classic Cotton Candy 6oz Cup		Box	2 2	29.40	58.80
DEC116	1848924207	1-12 Sundae Classic Strawberry 6oz Cup		Box	2 2	29.40	58.80
LAB301	1211300050	1-18 Super Pop RWB 4.5oz		Box	1 1	28.80	28.80
DEC025	1848924222	1-24 Chip Around 5oz		Box	1 1	58.80	58.80
WON033	2391100004	1-24 Dino Sour Orange Sherb Push Up 2.75oz		Box	1 1	38.40	38.40
DEC087	1848924283	1-24 Jolly Roger Cone Cup - Cotton Candy 3.75 oz		Box	1 1	38.40	38.40
DEC086	1848924284	1-24 Jolly Roger Cone Cup-Watermelon Sour Apple 3.75 oz		Box	1 1	38.40	38.40
DEC048	1848924289	1-24 Mega Ice Cream Sandwich 6oz		Box	1 1	36.00	36.00
ICS005	7273060640	1-24 Northstar Just Dipped Ice Cream Bar (6/case)		Box	1 1	38.40	38.40
DOV007	4767748248	1-24 Snickers - Peanut Big One (2/case)		Box	1 1	48.00	48.00
DEC028	1848924322	1-24 Strawberry Shortcake (6/case)		Box	0 0	38.40	0.00
DOV036	4767747420	1-24 Twix Bar King Size (2/case)		Box	1 1	48.00	48.00

Past Due Balances Subject to 1.5% Monthly Late Fee

0.00

Invoice Summary	QUANTITY ORDERED	QUANTITY SHIPPED	GROSS AMOUNT	SALES TAX		TOTAL AMOUNT
	20.00	20.00	675.60	0.00	0.00	675.60



REMIT TO:
 DECONNA ICE CREAM
 6300 W Hwy 318
 Reddick, FL 32686
 (352) 591-1530

Invoice	
NUMBER	DEL DATE
INV00425054	2/19/2026
ORDER NUMBER	ORD DATE
TP2492640	2/17/2026
INVOICE DUE: 2/19/2026	
TERMS: Check	

Ship To:

The Mirabay Club
 107 Manns Harbor Drive
 Apollo Beach, FL 33572
 (813)649-1500-Extn.0000

CORRESPONDENCE TO:

Tampa
 4605 N. Clark Avenue
 Tampa, FL 33614

Bill To:

The Mirabay Club
 Harbor Bay CDD
 107 Manns Harbor Drive
 Apollo Beach, FL 33572
 Hillsborough

1 of 1

CUSTOMER NUMBER	PO ORDER NUMBER	SALESPERSON ID	SHIPPING METHOD	DELIVERY DATE	ROUTE
THEMIRABAYCLUB		Mark Bishop	LOCAL DELIVERY	2/19/2026	TP-F-7A
CUSTOMER CLASS ID				DRIVER	REFERENCE NUMBER
FRZR-TAMPA	TAMPA			Reggie Hearn	0

ITEM NUMBER	UPC	DESCRIPTION	U OF M	ORDERED	SHIPPED	UNIT PRICE	EXT PRICE
DEC117	1848924203	1-12 Sundae Classic Chocolate 6oz Cup		Box	1 1	29.40	29.40
DEC115	1848924202	1-12 Sundae Classic Cotton Candy 6oz Cup		Box	1 1	29.40	29.40
DEC025	1848924222	1-24 Chip Around 5oz		Box	1 1	58.80	58.80
DEC029	1848924242	1-24 Everyday Sundae Cone 4.5oz		Box	1 1	48.00	48.00
DEC048	1848924289	1-24 Mega Ice Cream Sandwich 6oz		Box	1 1	36.00	36.00

52000-3122

Past Due Balances Subject to 1.5% Monthly Late Fee

0.00

Invoice Summary	QUANTITY ORDERED	QUANTITY SHIPPED	GROSS AMOUNT	SALES TAX		TOTAL AMOUNT
	5.00	5.00	201.60	0.00	0.00	201.60



Invoice #40085

From

FMX
 Facilities Management Express, LLC
 800 Yard Street, Suite 115
 Columbus, OH 43212
 (844) 664-4400
 billing@gofmx.com

Invoice Summary

Invoice Number	40085
Date	02/16/2026
Terms	Net 30
Due Date	03/18/2026
Amount Due (USD)	\$ 465.76

Bill To

Harbor Bay CDD
 c/o Rizzetta & Company
 3434 Colwell Avenue, Suite 200
 Tampa, FL 33614
 United States
 cddinvoice@rizzetta.com, fieldops@mirabayclub.com

Item / Description	Amount
FMX Annual Subscription Fee	423.42
FMX Software Sales Annual Software License (02/16/2026 to 03/15/2026)	
FMX Admin Fee	42.34
FMX Admin Fee (02/16/2026 to 03/15/2026)	
Amount Due (USD)	\$ 465.76

Payment via ACH or through Stripe (links below) is preferred.

By Wire Transfer or ACH:

- Huntington National Bank
- International Services EA2E85
- 7 Easton Oval, Columbus, OH 43219
- Routing & Transit: 044000024
- Account No: 01893040205
- For the Credit of: Facilities Management Express, LLC.
- SWIFT ID: HUNTUS33 (for International transfers)
- Remittance Advice: billing@gofmx.com

Checks can be mailed to the following address:

- Facilities Management Express, LLC
- L-4410
- Columbus, OH 43260

[FMX Terms of Use](#)

Date- 02-20-26
 GL Code- 520004837
 Approved by- [Signature]

PEPIN DISTRIBUTING INC.
 4121 N. 50th Street,
 Tampa, Florida 33610
 Phone: 813.626.6176

Wed Feb 11, 2026 6:35 AM
 Load: 3055

Invoice#: 4268497

(B) HARBOR BAY CDD
 THE MIRABAY CLUB
 107 MANNS HARBOR DRIVE
 APOLLO BEACH, FL 33572
 (813) 626-6176

Account : 99377 PO#:
 License : 3909377 Expires Sep 30, 2026
 Terms : PREPAID
 Driver : 055 - MATT GREAUX
 Salesrep: 355 - RICK HILTON # (813) 309-0426

Special Instructions

Invoice Comments

 ITEM# DESCRIPTION QTY PRICE DISCOUNT DEP TOTAL

00004 EMPTY AB 1/2 BBL -1 0.00 0.00 30.00 -30.00

 Subtotal Cases: -1 Units: -1

PALLET 1869421

00296 KONA BIG WAVE 1/6 BBL 1 74.20 6.00 30.00 104.20
 07794 ULT 1/2 BBL 1 148.55 0.00 30.00 178.55

 PALLET 1869421 Subtotal Cases: 2 Units: 2

PALLET 1869422

05446 BUD LIGHT CALNR 2/12/16 1 26.73 3.90 0.00 26.73
 13692 STELLA 18/12 CAN 1 24.83 0.00 0.00 24.83
 00419 CORONA 18/12 CAN 1 22.40 0.00 0.00 22.40
 12341 MODELO ORO 2/12/12 CAN 1 29.58 0.00 0.00 29.58

 PALLET 1869422 Subtotal Cases: 4 Units: 6

 Cases: 4 Total Selling Units: 8
 Bottles: 0
 Kegs: 2
 Misc: 0
 Credits: -1
 Gallons: 29.29

 Total Sales : 336.19
 Total Discount: -9.90
 Total Credits : -30.00
 Total Deposit : 60.00
 Invoice Total : 356.29

A/R DETAIL

 INVOICE# DATE BALANCE AGE TYPE

 4268497 Feb 11 2026 \$356.29 0 BEER

PAYMENT TOTALS

 PAYMENT TYPE AMOUNT

Invoice Total 356.29

Southern Glazer's of FL
License# 6305005 (Lakeland)

DRAFT INVOICE
4944791



REMIT TO:
1-866-375-9665
P.O. BOX 947921
ATLANTA GA 30394-7921

Stop #: 6
Route #: 079
Delivered By: Henry Johnson
Sales Person: 451
Sales Person Phone:

SOLD TO	SHIP TO
THE MIRABAY CLUB/HARBOR BAY CO 107 MANNS HARBOR DR. APOLLO BEACH FL 33572	THE MIRABAY CLUB/HARBOR BAY CO 107 MANNS HARBOR DR. APOLLO BEACH FL 33572 813-649-1500

Customer Name: FINTECH

PO NUMBER	DEX	PERMIT	PERMIT EXP	INVOICE DATE	DELIVERY DATE/TIME
	N	39-DR377	9/30/26	2/11/2026	
ACCOUNT#	VENDOR#	COUNTY	REFERENCE#		
15004510					

CS/BT	ITEM	UNIT NET PRICE	UNIT DISCOUNT	UNIT AMOUNT	TAXES	TOTAL
1 / 0	JOSH CELLARS PROSECCO ITEM#: 925073 BPC: 12 - 750ML HYBRIS - PART OF A DEAL D000310	189.00 15.75	54.00 4.50	135.00 11.25	0.00	135.00
1 / 0	MONDAVI PRV SEL CHARD CA(SC) ITEM#: 550559 BPC: 12 - 750ML HYBRIS - PART OF A DEAL D000312	144.00 12.00	78.00 6.50	66.00 5.50	0.00	66.00
1 / 0	MONDAVI PRV SEL PINOT GRIGIO ITEM#: 168069 BPC: 12 - 750ML HYBRIS - PART OF A DEAL D000312	144.00 12.00	78.00 6.50	66.00 5.50	0.00	66.00
2 / 0	MONDAVI PRV SEL SAUV BL CA(S) ITEM#: 416976 BPC: 12 - 750ML HYBRIS - PART OF A DEAL D000312	144.00 12.00	79.00 6.50	66.00 5.50	0.00	132.00
0 / 6	TITOS HANDMADE VODKA 80 ITEM#: 46599 BPC: 12 - 1L HYBRIS -	30.83	0.00	30.83	0.00	184.98

TOTAL CS/BTLS	TOTAL BOTTLES	TOTAL GROSS AMT	TOTAL DISCOUNTS	ESTIMATED NET AMOUNT	TOTAL TAXES
5/6	66	949.96	366.00	583.96	0.00

PAYMENT DUE DATE
2/23/26

PAY THIS AMOUNT
583.98

PAYMENT TERMS: FINTECH

TERMS AND CONDITIONS	TERMS
<p>Buyer represents that it is authorized under applicable law to purchase all the products delivered in this invoice, and that all such products were ordered by buyer and have been received without any damage, unless noted on invoice at time of delivery. SELLER EXPRESSLY DISCLAIMS ANY WARRANTY, INCLUDING OF MERCHANTABILITY OR FITNESS FOR A PARTICULAR PURPOSE. BUYER WAIVES CONSEQUENTIAL, PUNITIVE, TREBLE, OR STATUTORY DAMAGES OR PENALTIES. The parties agree to arbitrate any disputes between them on an individual basis in Miami, FL before the American Arbitration Association in accordance with its Commercial Arbitration Rules. The parties each waive the right to serve as a class or PAGA representative or to participate in a class or collective action in any legal proceeding between them.</p>	<p>If not paid according to invoice terms, seller may revoke credit, rescind discounts, report buyer as delinquent to appropriate agencies, and, if seller prevails, recover its costs of collection and attorney's fees. Returned checks are subject to the lower of \$30 or the highest fee allowed by law. Past due balances will accrue interest at the lesser of the highest rate permitted or required by law, or 1.5% per month pro-rated. Buyer hereby grants, as security for the payment of the purchase price, a lien up and security interest in all right, title, and interest of the buyer in the products delivered with this invoice. The security interest granted constitutes a PMSI under the UCC. Any taxes in conflict with or prohibited by applicable law are void.</p>
<p>NO CLAIMS FOR SHORTAGES WILL BE ALLOWED UNLESS INSPECTED AND NOTED AT TIME OF DELIVERY</p>	
<p>Wednesday, 2/11/2026 DATE</p>	

EVERGREEN COMMUNITY DEVELOPMENT DISTRICT

DISTRICT OFFICE · WESLEY CHAPEL, FLORIDA (239) 936-0913
MAILING ADDRESS · 3434 COLWELL AVENUE, SUITE 200 · TAMPA, FLORIDA 33614

Operation and Maintenance Expenditures February 2026 For Board Approval

Attached please find the check register listing the Operation and Maintenance expenditures paid from February 1, 2026 through February 28, 2026. This does not include expenditures previously approved by the Board.

The total items being presented: **\$4,018.95**

Approval of Expenditures:

_____ Chairperson

_____ Vice Chairperson

_____ Assistant Secretary

Evergreen Community Development District

Paid Operation & Maintenance Expenditures

February 1, 2026 Through February 28, 2026

<u>Vendor Name</u>	<u>Check Number</u>	<u>Invoice Number</u>	<u>Invoice Description</u>	<u>Invoice Amount</u>
Off Duty Management, Inc	100023	INV290098	Off Duty 12/25	\$ 927.45
Off Duty Management, Inc	100023	INV301756	Off Duty 01/26	\$ 618.30
Off Duty Management, Inc	100023	INV304407	Off Duty 01/26	\$ 1,236.60
Off Duty Management, Inc	100023	INV307787	Off Duty - Jones 01/26	\$ 309.15
Off Duty Management, Inc	100024	INV310661	Off Duty 02/26	<u>\$ 927.45</u>
Report Total				<u>\$ 4,018.95</u>



Invoice

INV290098

Off Duty Management Inc.
1906 Avenue D #200
Katy, TX 77493
281-347-8500
invoicing@offdutymanagement.com

12/18/2025
Terms: Net 30
Due Date: 1/17/2026

Bill To Attn To:
Vanessa Smith
Harbor Bay CDD : Marine Unit
4530 Eagle Falls Place
Tampa FL 33619
United States

WorkSite Address
Vanessa Smith
Channel Drive
Tampa FL 33606
US

Make Check Payable and Mail to:
Off Duty Management, Inc.
P.O. Box 737377
Dallas ,TX 75373-7377
Please include invoice number with payment

Project	PO	Job #/Ref #	Amount Due
152995 Harbor Bay CDD : Marine Unit : ODM-20251120-0051:Harbor Bay CDD*:Marine			\$927.45

Agency	Time IN - Time OUT	Officer	Type	Hours/ Qty	Rate	Amount
Hillsborough County-SO-FL	12/8/2025 6:00:00 AM - 12/8/2025 11:00:00 AM	Kevin Withey	Regular	5	\$61.83	\$309.15
Hillsborough County-SO-FL	12/9/2025 6:00:00 AM - 12/9/2025 11:00:00 AM	Scott Jones-03	Regular	5	\$61.83	\$309.15
Hillsborough County-SO-FL	12/12/2025 6:00:00 AM - 12/12/2025 11:00:00 AM	Scott Jones-03	Regular	5	\$61.83	\$309.15
Regular Total						\$927.45

Invoice Comments:

Request Id: ODM-20251120-0051

Invoice Subtotal	\$927.45
Tax Total	\$0.00
Invoice Total	\$927.45
Total Paid	\$0.00
Amount Due	\$927.45





Invoice

INV301756

Off Duty Management Inc.
1906 Avenue D #200
Katy, TX 77493
281-347-8500
invoicing@offdutymanagement.com

1/22/2026
Terms: Net 30
Due Date: 2/21/2026

Bill To Attn To:
Vanessa Smith
Harbor Bay CDD : Marine Unit
4530 Eagle Falls Place
Tampa FL 33619
United States

WorkSite Address
Vanessa Smith
Channel Drive
Tampa FL 33606
US

Make Check Payable and Mail to:
Off Duty Management, Inc.
P.O. Box 737377
Dallas ,TX 75373-7377
Please include invoice number with payment

Project	PO	Job #/Ref #	Amount Due
152995 Harbor Bay CDD : Marine Unit : ODM-20251120-0051:Harbor Bay CDD*:Marine			\$618.30

Agency	Time IN - Time OUT	Officer	Type	Hours/ Qty	Rate	Amount
Hillsborough County-SO-FL	1/14/2026 6:00:00 AM - 1/14/2026 11:00:00 AM	Scott Jones-03	Regular	5	\$61.83	\$309.15
Hillsborough County-SO-FL	1/16/2026 1:00:00 PM - 1/16/2026 6:00:00 PM	Kevin Withey	Regular	5	\$61.83	\$309.15
Regular Total						\$618.30

Invoice Comments:

Request Id: ODM-20251120-0051

Invoice Subtotal	\$618.30
Tax Total	\$0.00
Invoice Total	\$618.30
Total Paid	\$0.00
Amount Due	\$618.30



INV301756



Invoice

INV304407

Off Duty Management Inc.
 1906 Avenue D #200
 Katy, TX 77493
 281-347-8500
 invoicing@offdutymanagement.com

1/29/2026
 Terms: Net 30
 Due Date: 2/28/2026

Bill To Attn To:
 Vanessa Smith
 Harbor Bay CDD : Marine Unit
 4530 Eagle Falls Place
 Tampa FL 33619
 United States

WorkSite Address
 Vanessa Smith
 Channel Drive
 Tampa FL 33606
 US

Make Check Payable and Mail to:
 Off Duty Management, Inc.
 P.O. Box 737377
 Dallas ,TX 75373-7377
Please include invoice number with payment

Project	PO	Job #/Ref #	Amount Due
152995 Harbor Bay CDD : Marine Unit : ODM-20251120-0051:Harbor Bay CDD*:Marine			\$1,236.60

Agency	Time IN - Time OUT	Officer	Type	Hours/ Qty	Rate	Amount
Hillsborough County-SO-FL	1/20/2026 9:00:00 AM - 1/20/2026 2:00:00 PM	Scott Jones-03	Regular	5	\$61.83	\$309.15
Hillsborough County-SO-FL	1/21/2026 1:00:00 PM - 1/21/2026 6:00:00 PM	Scott Jones-03	Regular	5	\$61.83	\$309.15
Hillsborough County-SO-FL	1/23/2026 6:00:00 AM - 1/23/2026 11:00:00 AM	Kevin Withey	Regular	5	\$61.83	\$309.15
			Regular Total			\$927.45
Hillsborough County-SO-FL	1/19/2026 6:00:00 AM - 1/19/2026 11:00:00 AM	Kevin Withey	Holiday	5	\$61.83	\$309.15
			Holiday Total			\$309.15

Invoice Comments:

Request Id: ODM-20251120-0051

Invoice Subtotal	\$1,236.60
Tax Total	\$0.00
Invoice Total	\$1,236.60
Total Paid	\$0.00
Amount Due	\$1,236.60





Invoice

INV307787

Off Duty Management Inc.
 1906 Avenue D #200
 Katy, TX 77493
 281-347-8500
 invoicing@offdutymanagement.com

2/5/2026
 Terms: Net 30
 Due Date: 3/7/2026

Bill To Attn To:
 Vanessa Smith
 Harbor Bay CDD : Marine Unit
 4530 Eagle Falls Place
 Tampa FL 33619
 United States

WorkSite Address
 Vanessa Smith
 Channel Drive
 Tampa FL 33606
 US

Make Check Payable and Mail to:
 Off Duty Management, Inc.
 P.O. Box 737377
 Dallas ,TX 75373-7377
Please include invoice number with payment

Project	PO	Job #/Ref #	Amount Due
152995 Harbor Bay CDD : Marine Unit : ODM-20251120-0051:Harbor Bay CDD*:Marine			\$309.15

Agency	Time IN - Time OUT	Officer	Type	Hours/ Qty	Rate	Amount
Hillsborough County-SO-FL	1/26/2026 1:00:00 PM - 1/26/2026 6:00:00 PM	Scott Jones-03	Regular	5	\$61.83	\$309.15
Regular Total						\$309.15

Invoice Comments:

Request Id: ODM-20251120-0051

Invoice Subtotal	\$309.15
Tax Total	\$0.00
Invoice Total	\$309.15
Total Paid	\$0.00
Amount Due	\$309.15



INV307787



Invoice

INV310661

Off Duty Management Inc.
 1906 Avenue D #200
 Katy, TX 77493
 281-347-8500
 invoicing@offdutymanagement.com

2/12/2026
 Terms: Net 30
 Due Date: 3/14/2026

Bill To Attn To:
 Vanessa Smith
 Harbor Bay CDD : Marine Unit
 4530 Eagle Falls Place
 Tampa FL 33619
 United States

WorkSite Address
 Vanessa Smith
 Channel Drive
 Tampa FL 33606
 US

Make Check Payable and Mail to:
 Off Duty Management, Inc.
 P.O. Box 737377
 Dallas ,TX 75373-7377
Please include invoice number with payment

Project	PO	Job #/Ref #	Amount Due
152995 Harbor Bay CDD : Marine Unit : ODM-20251120-0051:Harbor Bay CDD*:Marine			\$927.45

Agency	Time IN - Time OUT	Officer	Type	Hours/ Qty	Rate	Amount
Hillsborough County-SO-FL	2/2/2026 6:00:00 AM - 2/2/2026 11:00:00 AM	Scott Jones-03	Regular	5	\$61.83	\$309.15
Hillsborough County-SO-FL	2/3/2026 6:00:00 AM - 2/3/2026 11:00:00 AM	Kevin Withey	Regular	5	\$61.83	\$309.15
Hillsborough County-SO-FL	2/6/2026 6:00:00 AM - 2/6/2026 11:00:00 AM	Scott Jones-03	Regular	5	\$61.83	\$309.15
Regular Total						\$927.45

Invoice Comments:

Request Id: ODM-20251120-0051

Invoice Subtotal	\$927.45
Tax Total	\$0.00
Invoice Total	\$927.45
Total Paid	\$0.00
Amount Due	\$927.45



Tab 17



Rizzetta & Company

Harbor Bay Community Development District

**Financial Statements
(Unaudited)**

February 28, 2026

Prepared by: Rizzetta & Company, Inc.

harborbaycdd.org
rizzetta.com

Harbor Bay Community Development District
Balance Sheet
As of 02/28/2026
(In Whole Numbers)

	General Fund	Reserve Fund	Debt Service Fund	Mira Bay Fund	Evergreen Fund	Total Gvmnt Fund	Long-Term Debt
Assets							
Cash In Bank	154,557	(18,450)	0	110,593	9,698	256,399	0
Investments	2,827,282	2,923,961	2,781,046	0	209,866	8,742,154	0
Accounts Receivable							
Accounts Receivable - Other	31,560	0	0	7,568	0	39,128	0
Assessments Receivable-Tax Roll	396,175	0	156,875	0	0	553,051	0
Allowance for Uncollectible Accounts	(28,796)	0	0	(7,568)	0	(36,364)	0
Prepaid Expenses	84,946	0	0	1,669	0	86,615	0
Inventory	0	0	0	27,576	0	27,576	0
Refundable Deposits	2,956	0	0	0	0	2,956	0
Due From Other	42,350	0	0	500	0	42,850	0
Amount Available in Debt Service	0	0	0	0	0	0	2,937,921
Amount To Be Provided Debt Service	0	0	0	0	0	0	18,557,079
Total Assets	3,511,030	2,905,511	2,937,921	140,338	219,564	9,714,365	21,495,000
Liabilities							
Accounts Payable	172,782	18,450	0	5,970	0	197,202	0
Accrued Expenses	10,095	0	0	0	0	10,095	0
Other Current Liabilities	0	0	0	5,580	0	5,581	0
Due To Other	8,397	0	0	35,798	1,582	45,776	0
Revenue Bonds Payable-Long Term	0	0	0	0	0	0	21,495,000
Deposits Payable	0	0	0	100	0	100	0
Total Liabilities	191,274	18,450	0	47,448	1,582	258,754	21,495,000
Fund Equity & Other Credits							
Beginning Fund Balance	691,453	2,285,495	1,442,986	64,075	214,649	4,698,658	0
Net Change in Fund Balance	2,628,303	601,566	1,494,935	28,816	3,333	4,756,953	0
Total Fund Equity & Other Credits	3,319,756	2,887,061	2,937,921	92,891	217,982	9,455,611	0
Total Liabilities & Fund Equity	3,511,030	2,905,511	2,937,921	140,338	219,564	9,714,365	21,495,000

See Notes to Unaudited Financial Statements

Harbor Bay Community Development District

Statement of Revenues and Expenditures

As of 02/28/2026

(In Whole Numbers)

	Year Ending 09/30/2026 Annual Budget	Through 02/28/2026 YTD Budget	Year To Date 02/28/2026 YTD Actual	YTD Variance
Revenues				
Interest Earnings				
Interest Earnings	82,000	34,167	23,370	(10,797)
Special Assessments				
Tax Roll	4,116,557	4,116,557	4,150,631	34,074
Other Misc. Revenues				
HOA Rental Revenue	600	250	0	(250)
Insurance Proceeds	0	0	186,582	186,582
Miscellaneous Revenue	15,000	6,250	39	(6,210)
Total Revenues	4,214,157	4,157,224	4,360,622	203,399
Expenditures				
Legislative				
Supervisor Fees	12,000	5,000	5,000	0
Total Legislative	12,000	5,000	5,000	0
Financial & Administrative				
Accounting Services	58,146	24,228	21,583	2,644
Arbitrage Rebate Calculation	650	650	500	150
Auditing Services	5,200	0	0	0
Disclosure Report	5,600	2,333	2,083	250
District Engineer	55,000	22,917	32,760	(9,844)
District Engineer - Special	66,583	27,743	10,388	17,356
District Management	129,214	53,839	52,246	1,593
Dues, Licenses & Fees	4,500	1,735	895	840
Financial & Revenue Collections	9,692	4,038	2,083	1,955
Legal Advertising	1,800	750	315	435
Miscellaneous Expense	0	0	158	(158)
Miscellaneous Mailings	1,500	625	0	625
Property Taxes	4,500	4,500	3,967	534
Public Officials Liability Insurance	20,261	20,261	4,800	15,461
Trustees Fees	7,100	5,837	6,420	(584)
Website Hosting, Maintenance, Backup & E	10,752	3,177	1,172	2,005
Total Financial & Administrative	380,498	172,633	139,370	33,262
Legal Counsel				
District Counsel	130,000	54,167	105,808	(51,641)
District Counsel - Special Counsel	25,000	10,416	4,883	5,534
Total Legal Counsel	155,000	64,583	110,691	(46,107)
Security Operations				
Gate Maintenance & Repair	0	0	2,570	(2,570)
Security Monitoring Services	222,000	92,500	95,742	(3,242)
Total Security Operations	222,000	92,500	98,312	(5,812)
Electric Utility Services				
Utility - Irrigation	26,000	10,834	11,644	(812)
Utility - Recreation Facilities	100,000	41,666	52,978	(11,311)
Utility - Street Lights	200,000	83,334	62,809	20,524

See Notes to Unaudited Financial Statements

Harbor Bay Community Development District

Statement of Revenues and Expenditures

As of 02/28/2026

(In Whole Numbers)

	Year Ending 09/30/2026	Through 02/28/2026	Year To Date 02/28/2026	
	Annual Budget	YTD Budget	YTD Actual	YTD Variance
Utility Services -Guard House	6,500	2,708	1,605	1,104
Total Electric Utility Services	332,500	138,542	129,036	9,505
Gas Utility Service				
Utility Services	6,500	2,708	2,779	(71)
Total Gas Utility Service	6,500	2,708	2,779	(71)
Garbage/Solid Waste Control Services				
Garbage - Recreation Facility	17,400	7,250	7,321	(71)
Total Garbage/Solid Waste Control Services	17,400	7,250	7,321	(71)
Water-Sewer Combination Services				
Utilities - Amenities	45,000	18,750	15,586	3,164
Utility - Irrigation	35,000	14,584	4,711	9,872
Total Water-Sewer Combination Services	80,000	33,334	20,297	13,036
Stormwater Control				
Aquatic Maintenance	70,460	29,358	19,912	9,447
Fountain Service Repair & Maintenance	25,000	10,417	3,391	7,025
Total Stormwater Control	95,460	39,775	23,303	16,472
Other Physical Environment				
Flood Insurance	8,315	8,315	2,432	5,883
General Liability & Property Insurance	199,948	199,948	157,762	42,186
Landscape - Annuals/Flowers	24,000	10,000	0	10,000
Landscape - Mulch	141,000	58,750	40,500	18,250
Landscape Irrigation	60,000	25,000	56,745	(31,745)
Landscape Maintenance	469,000	195,416	224,765	(29,348)
Landscape Maintenance - Contingency	100,000	41,667	0	41,667
Landscape Maintenance - Park Square	200,000	83,333	75,000	8,333
Landscape Maintenance - Turf Grass	283,220	118,008	118,008	0
Landscape Plant Installation	100,000	41,667	0	41,667
Water Management Monitoring & Reporting	6,000	2,500	2,500	0
Total Other Physical Environment	1,591,483	784,604	677,712	106,893
Road & Street Facilities				
Asphalt Repair & Maintenance	19,500	8,125	179	7,946
Street/Parking Lot Sweeping	15,000	6,250	6,528	(278)
Total Road & Street Facilities	34,500	14,375	6,707	7,668
Parks & Recreation				
Basketball Court Maintenance & Supplies	6,000	2,500	0	2,500
Boat Lift Sling Repairs & Maintenance	20,000	8,333	133	8,200
Dog Waste Station Supplies & Maintenance	0	0	1,317	(1,317)
Elevator Maintenance & Permit	3,616	1,507	1,132	375
Employee - Payroll Processing Fees	0	0	7,699	(7,699)
Employee - Payroll Taxes	0	0	49,087	(49,087)
Employee - Workers Comp	0	0	7,913	(7,913)
Facility A/C & Heating Maintenance &	5,000	2,083	0	2,084

See Notes to Unaudited Financial Statements

Harbor Bay Community Development District

Statement of Revenues and Expenditures

As of 02/28/2026

(In Whole Numbers)

	Year Ending 09/30/2026 Annual Budget	Through 02/28/2026 YTD Budget	Year To Date 02/28/2026 YTD Actual	YTD Variance
Rep				
Fitness Equipment Maintenance & Repair	7,500	3,125	3,239	(115)
Holiday Decorations	12,000	12,000	14,932	(2,932)
Janitorial Service	89,627	37,345	25,409	11,936
Maintenance & Repairs	40,000	16,667	39,672	(23,005)
Onsite Staffing/Employment	417,035	173,764	125,179	48,585
Pest Control	5,210	2,171	653	1,518
Playground Repairs	10,000	4,167	0	4,167
Pool Operations & Maintenance	42,087	17,536	24,818	(7,283)
Printing Supplies	1,500	625	874	(249)
Street Sign Repair & Replacement	7,500	3,125	5,876	(2,751)
Telephone, Internet, Cable	40,000	16,666	16,336	331
Tennis Court Maintenance & Supplies	9,734	4,056	3,818	238
Tennis Court Maintenance Personnel	33,996	14,165	1,663	12,502
Vehicle Maintenance	3,500	1,459	747	711
Total Parks & Recreation	754,305	321,294	330,497	(9,204)
Admiral Point Operations				
Utility - Electricity	21,600	9,000	4,833	4,167
Utility - Water & Sewer	5,500	2,291	1,476	817
Total Admiral Point Operations	27,100	11,291	6,309	4,984
Contingency				
CDD Annual Contribution	455,411	189,755	166,111	23,643
Emergency Relief	50,000	20,833	0	20,833
Reserve Study	0	0	2,350	(2,350)
Total Contingency	505,411	210,588	168,461	42,126
Total Expenditures	4,214,157	1,898,477	1,725,795	172,681
Total Excess of Revenues Over(Under) Expenditures	0	2,258,747	2,634,827	376,080
Total Other Financing Sources(Uses)				
Prior Year AP Credit				
Prior Year A/P Credits	0	0	(6,524)	(6,524)
Total Other Financing Sources(Uses)	0	0	(6,524)	(6,524)
Fund Balance, Beginning of Period	0	0	691,453	691,453
Total Fund Balance, End of Period	0	2,258,747	3,319,756	1,061,009

Harbor Bay Community Development District

Statement of Revenues and Expenditures

As of 02/28/2026

(In Whole Numbers)

	Year Ending 09/30/2026 <u>Annual Budget</u>	Through 02/28/2026 <u>YTD Budget</u>	Year To Date 02/28/2026 <u>YTD Actual</u>	<u>YTD Variance</u>
Revenues				
Interest Earnings				
Interest Earnings	75,000	31,250	44,787	13,537
Special Assessments				
Tax Roll	593,000	593,000	593,680	680
Total Revenues	<u>668,000</u>	<u>624,250</u>	<u>638,467</u>	<u>14,217</u>
Expenditures				
Contingency				
Asphalt Repair & Maintenance	288,822	120,343	0	120,342
Facility A/C & Heating Maintenance & Rep	60,000	25,000	0	25,000
Fountain Repairs	55,435	23,097	0	23,098
Landscape Enhancements	352,018	146,675	0	146,674
Paint Finish Applications, Exterior	72,067	30,027	0	30,028
Tennis Courts Resurfacing	39,393	16,414	36,900	(20,486)
Total Contingency	<u>867,735</u>	<u>361,556</u>	<u>36,900</u>	<u>324,656</u>
Total Expenditures	<u>867,735</u>	<u>361,556</u>	<u>36,900</u>	<u>324,656</u>
Total Excess of Revenues Over(Under) Expenditures	<u>(199,735)</u>	<u>262,694</u>	<u>601,567</u>	<u>338,873</u>
Total Other Financing Sources(Uses)				
Carry Forward Fund Balance				
Carry Forward Fund Balance	199,735	199,735	0	(199,735)
Total Other Financing Sources(Uses)	<u>199,735</u>	<u>199,735</u>	<u>0</u>	<u>(199,735)</u>
Fund Balance, Beginning of Period	<u>0</u>	<u>0</u>	<u>2,285,494</u>	<u>2,285,495</u>
Total Fund Balance, End of Period	<u>0</u>	<u>462,429</u>	<u>2,887,061</u>	<u>2,424,633</u>

Harbor Bay Community Development District

Statement of Revenues and Expenditures

As of 02/28/2026

(In Whole Numbers)

	Year Ending 09/30/2026 <u>Annual Budget</u>	Through 02/28/2026 <u>YTD Budget</u>	Year To Date 02/28/2026 <u>YTD Actual</u>	<u>YTD Variance</u>
Revenues				
Interest Earnings				
Interest Earnings	0	0	26,156	26,156
Special Assessments				
Tax Roll	1,865,136	1,865,136	1,878,628	13,492
Total Revenues	<u>1,865,136</u>	<u>1,865,136</u>	<u>1,904,784</u>	<u>39,648</u>
Expenditures				
Debt Service				
Interest	805,136	805,136	409,849	395,287
Principal	1,060,000	1,060,000	0	1,060,000
Total Debt Service	<u>1,865,136</u>	<u>1,865,136</u>	<u>409,849</u>	<u>1,455,287</u>
Total Expenditures	<u>1,865,136</u>	<u>1,865,136</u>	<u>409,849</u>	<u>1,455,287</u>
Total Excess of Revenues Over(Under) Ex- penditures	<u>0</u>	<u>0</u>	<u>1,494,935</u>	<u>1,494,935</u>
Fund Balance, Beginning of Period	<u>0</u>	<u>0</u>	<u>1,442,986</u>	<u>1,442,986</u>
Total Fund Balance, End of Period	<u>0</u>	<u>0</u>	<u>2,937,921</u>	<u>2,937,921</u>

Harbor Bay Community Development District

Statement of Revenues and Expenditures

As of 02/28/2026

(In Whole Numbers)

	Year Ending 09/30/2026 Annual Budget	Through 02/28/2026 YTD Budget	Year To Date 02/28/2026 YTD Actual	YTD Variance
Revenues				
Interest Earnings				
Interest Earnings	0	0	36	36
Amenity Center Revenue				
Beer Sales	29,962	12,484	11,408	(1,076)
Beverages	7,734	3,223	2,751	(471)
Events & Sponsorships	15,000	6,250	8,991	2,741
Facilities Rentals	41,778	17,407	14,147	(3,261)
Facility Rental - Bar Services	17,576	7,323	5,227	(2,096)
Food	84,090	35,038	30,923	(4,115)
Gate Strike Income	1,500	625	0	(625)
Group Exercises	1,680	700	370	(330)
Liquor	48,788	20,328	11,858	(8,470)
Merchandise	12,000	5,000	1,025	(3,975)
Non-Resident Basketball	2,500	1,042	0	(1,041)
Non-Resident Pickleball	4,000	1,667	0	(1,667)
Non-Resident Tennis	4,000	1,666	0	(1,667)
Personal Training	1,920	800	0	(800)
Programs-After School Care	56,500	23,542	0	(23,541)
Programs-Camps	54,000	22,500	0	(22,500)
Programs-Youth Other	1,500	625	0	(625)
Proximity Card Replacements	10,000	4,167	4,002	(165)
Special Events Revenue	3,154	1,314	2,699	1,385
Tennis Lessons	540	225	0	(225)
Vendor Rebates	0	0	74	73
Wine Sales	14,240	5,933	5,363	(570)
Other Misc. Revenues				
Contribution From CDD	455,411	189,755	166,111	(23,643)
Total Revenues	867,873	361,614	264,985	(96,628)
Expenditures				
Food & Beverage				
COGS - Beer	12,485	5,203	4,172	1,030
COGS - Beverage	3,653	1,522	3,197	(1,675)
COGS - Coffee	12,000	5,000	10,294	(5,294)
COGS - Food	72,914	30,380	22,233	8,147
COGS - Liquor	23,712	9,880	3,697	6,183
COGS - Wine	8,765	3,652	1,861	1,791
Cafe Operating	19,226	8,011	6,527	1,485
Daily Ops Software	9,000	3,750	2,328	1,421
Dues, Licenses & Fees	1,800	750	1	749
Food & Fun Events	5,000	2,084	4,203	(2,119)
Refrigeration Repairs	6,800	2,833	0	2,833
Training & Education	1,300	541	611	(69)
Total Food & Beverage	176,655	73,606	59,124	14,482
Operating Expense				
Amenity Management Service Contracts	218,083	90,868	85,641	5,227
Bank Fees	0	0	1,140	(1,141)

See Notes to Unaudited Financial Statements

Harbor Bay Community Development District

Statement of Revenues and Expenditures

As of 02/28/2026

(In Whole Numbers)

	Year Ending 09/30/2026	Through 02/28/2026	Year To Date 02/28/2026	
	Annual Budget	YTD Budget	YTD Actual	YTD Variance
Clubhouse Improvements	15,000	6,250	0	6,250
Employee Recognition	2,500	1,042	0	1,042
Food & Beverage Operations	140,041	58,350	17,943	40,407
Furniture, Fixtures, & Equipment	12,000	5,000	2,052	2,949
Gate Strikes	3,840	1,600	0	1,600
Gate Strikes - Mailing	500	209	0	208
General Operating	11,500	4,791	2,220	2,571
Gym Towels	7,500	3,125	0	3,125
Housekeeping Operating	40,000	16,667	31,947	(15,280)
ID & Access Cards	16,000	6,667	0	6,667
Marketing & Promotions	3,012	1,255	0	1,255
Member & Guest Supplies	14,462	6,025	1,028	4,998
Merchandise Retail	6,200	2,584	0	2,583
Office Supplies	8,460	3,525	594	2,931
Postage & Delivery	300	125	0	125
Uniforms & Laundry	750	312	0	312
Total Operating Expense	500,148	208,395	142,565	65,829
Parks & Recreation				
After School Program	4,100	1,709	2,483	(774)
Camps	15,000	6,250	0	6,250
Continuing Education - CPR	800	333	0	333
Employee - Lifeguards	91,030	37,929	7,133	30,796
Lifeguard Supplies	1,800	750	20	730
Marketing & Promotions	1,550	646	0	646
Youth Programs	1,000	416	0	416
Total Parks & Recreation	115,280	48,033	9,636	38,397
Special Events				
Back to School	3,500	1,459	0	1,459
Bartending Events	11,290	4,704	0	4,704
Eggstravaganza	4,000	1,667	0	1,667
Harvest Fest	14,000	5,833	0	5,833
Program Operating	5,000	2,083	94	1,989
Santa Brunch	2,500	1,042	2,400	(1,358)
Special Events	20,000	8,333	21,250	(12,917)
Sunday Market	1,000	417	0	417
Winter Wonderland	14,500	6,041	1,100	4,941
Total Special Events	75,790	31,579	24,844	6,735
Total Expenditures	867,873	361,613	236,169	125,443
Total Excess of Revenues Over(Under) Expenditures	0	1	28,816	28,815
Fund Balance, Beginning of Period	0	0	64,075	64,075
Total Fund Balance, End of Period	0	1	92,891	92,890

See Notes to Unaudited Financial Statements

Harbor Bay Community Development District

Statement of Revenues and Expenditures

As of 02/28/2026

(In Whole Numbers)

	Year Ending 09/30/2026 <u>Annual Budget</u>	Through 02/28/2026 <u>YTD Budget</u>	Year To Date 02/28/2026 <u>YTD Actual</u>	<u>YTD Variance</u>
Revenues				
Interest Earnings				
Interest Earnings	7,500	3,125	3,566	441
Other Misc. Revenues				
Boat Registrations	12,000	5,000	7,818	2,818
Boat Renewals	5,000	2,083	4,000	1,917
Total Revenues	<u>24,500</u>	<u>10,208</u>	<u>15,384</u>	<u>5,176</u>
Expenditures				
Other Physical Environment				
Canal Inspections	1,200	500	0	500
Harbor Patrol	30,000	12,500	12,051	449
Navigational Post & Sign Repairs	22,000	9,166	0	9,166
Save the Manatees	50,000	20,834	0	20,834
Total Other Physical Environment	<u>103,200</u>	<u>43,000</u>	<u>12,051</u>	<u>30,949</u>
Total Expenditures	<u>103,200</u>	<u>43,000</u>	<u>12,051</u>	<u>30,949</u>
Total Excess of Revenues Over(Under) Ex- penditures	<u>(78,700)</u>	<u>(32,792)</u>	<u>3,333</u>	<u>36,125</u>
Total Other Financing Sources(Uses)				
Carry Forward Fund Balance				
Carry Forward Fund Balance	78,700	78,700	0	(78,700)
Total Other Financing Sources(Uses)	<u>78,700</u>	<u>78,700</u>	<u>0</u>	<u>(78,700)</u>
Fund Balance, Beginning of Period	<u>0</u>	<u>0</u>	<u>214,649</u>	<u>214,649</u>
Total Fund Balance, End of Period	<u>0</u>	<u>45,908</u>	<u>217,982</u>	<u>172,074</u>

**Harbor Bay CDD
Investment Summary
February 28, 2026**

<u>Account</u>	<u>Investment</u>	<u>Balance as of February 28, 2026</u>
Florida Fixed Income Trust	Local Government Investment	\$ 2,827,282
	Total General Fund Investments	<u>\$ 2,827,282</u>
Florida Fixed Income Trust	Local Government Investment	\$ 2,923,961
	Total General Reserve Fund Investments	<u>\$ 2,923,961</u>
US Bank Series 2019 Reserve	First American Government Obligation Fund Class Y	\$ 931,008
US Bank Series 2019 Revenue	First American Government Obligation Fund Class Y	1,848,856
US Bank Series 2019A-1 Prepayment	First American Government Obligation Fund Class Y	435
US Bank Series 2019A-2 A1 Prepayment	First American Government Obligation Fund Class Y	535
US Bank Series 2019A-2 A2 Prepayment	First American Government Obligation Fund Class Y	212
	Total Debt Service Fund Investments	<u>\$ 2,781,046</u>
Florida Fixed Income Trust	Local Government Investment	\$ 209,866
	Total Evergreen Fund Investments	<u>\$ 209,866</u>

FirstService Financial, an affiliate by ownership to your management company Rizzetta & Company, provides banking solutions exclusively to clients of Rizzetta & Company. FirstService Financial receives a monthly administration fee from partner financial institutions for our assistance with the development, placement, service, and maintenance of our banking programs without impacting the interest our clients earn on their funds. The monthly administration fee varies as it is negotiated with each participating financial institution.

**Harbor Bay Community Development District
Summary A/R Ledger
From 02/01/2026 to 02/28/2026**

Fund_ID	Fund Name	Customer	Invoice Number	AR Account	Date	Balance Due	
815, 192	815-001	815 General Fund	Hillsborough County Tax Collec- tor	AR00003098	12110	10/01/2025	396,175.05
Sum for 815, 192							396,175.05
815, 196	815-200	815 Debt Service Fund S2019	Hillsborough County Tax Collec- tor	AR00003098	12110	10/01/2025	156,875.35
Sum for 815, 196							156,875.35
Sum for 815							553,050.40
Sum Total							553,050.40

See Notes to Unaudited Financial Statements

**Harbor Bay Community Development District
Summary A/P Ledger
From 02/01/2026 to 02/28/2026**

Fund Name	GL posting date	Vendor name	Document number	Description	Balance Due
815, 190					
815 Mira Bay Enterprise Fund	02/01/2026	Alsco, Inc.	LTAM1117627	Supplies 02/26	108.00
815 Mira Bay Enterprise Fund	02/01/2026	Cheney Brothers, Inc.	06-910146289	Food 02/26	19.73
815 Mira Bay Enterprise Fund	02/01/2026	Cheney Brothers, Inc.	06-910146851	Food & Supplies 02/26	258.68
815 Mira Bay Enterprise Fund	02/01/2026	Cheney Brothers, Inc.	06-910146339	Food 02/26	77.40
815 Mira Bay Enterprise Fund	02/01/2026	Cheney Brothers, Inc.	06-910146851	Food & Supplies 02/26	387.17
815 Mira Bay Enterprise Fund	02/01/2026	Cheney Brothers, Inc.	06-910146851	Food & Supplies 02/26	196.78
815 Mira Bay Enterprise Fund	02/01/2026	Cintas Corporation	1906158695	Supplies 02/26	640.00
815 Mira Bay Enterprise Fund	02/01/2026	Cintas Corporation	4260241912	Supplies 02/26	1,258.09
815 Mira Bay Enterprise Fund	02/01/2026	Cintas Corporation	1906146993	Supplies 02/26	320.00
815 Mira Bay Enterprise Fund	02/01/2026	Cintas Corporation	4261019854	Supplies 02/26	1,233.49
815 Mira Bay Enterprise Fund	01/01/2026	Coca-Cola Beverages Florida, LLC	50775647015	Beverage CM 01/26	(225.00)
815 Mira Bay Enterprise Fund	02/01/2026	Coca-Cola Beverages Florida, LLC	51174874010	Beverage 02/26	284.17
815 Mira Bay Enterprise Fund	02/01/2026	Pepin	4277034	Beer 02/26	415.72
815 Mira Bay Enterprise Fund	11/01/2025	Southern Glazers Wine and Spirits, LLC	1004496669 ACH	wine 11/25	264.00
815 Mira Bay Enterprise Fund	02/01/2026	Southern Glazers Wine and Spirits, LLC	4992850	Wine 02/26	731.51
Sum for 815, 190					5,969.74
815, 192					
815 General Fund	02/01/2026	Blue Water Aquatics, Inc.	35119	Aquatic Maintenance 02/26	3,640.00
815 General Fund	02/01/2026	Blue Water Aquatics, Inc.	35121	Aquatic Plants 12/26	2,276.50
815 General Fund	02/01/2026	Business First Insurance Company	13874962	Workers Comp 02/26	1,492.67
815 General Fund	02/01/2026	Core Empire, LLC	336	Pressure Washing 02/26	2,400.00
815 General Fund	02/01/2026	Gas South	150887437405	Utility Services 02/26	855.76
815 General Fund	02/01/2026	Hillsborough County BOCC	3432900000-031926	5332 Loon Nest Ct 02/26	49.23
815 General Fund	02/01/2026	Hillsborough County BOCC	7788800000-031926	736 Manns Harbor Dr 02/26	235.56
815 General Fund	02/01/2026	Hillsborough County BOCC	6542900000-031926	5231 Point Harbor Ln 02/26	82.72
815 General Fund	02/01/2026	Hillsborough County BOCC	1779718759-031926	5248 Admiral Pointe 02/26	322.30
815 General Fund	02/01/2026	Hillsborough County BOCC	9406800000-031926	107 Manns Harbor Dr 02/26	2,818.53
815 General Fund	02/01/2026	Hillsborough County BOCC	5432900000-031926	5325 Fishersound Ln 02/26	33.41
815 General Fund	02/01/2026	Hillsborough County BOCC	4432900000-031926	751 Manns Harbor Dr 02/26	64.30
815 General Fund	02/01/2026	Hillsborough County BOCC	3985020000-031726	5701 Sea Trout Pl 02/26	104.80
815 General Fund	02/01/2026	Hillsborough County BOCC	4542900000-031726	5405 Merrit Island Dr 02/26	93.69
815 General Fund	02/01/2026	Hillsborough County BOCC	4106020000-031726	5401 Tybee Island Dr 02/26	46.40
815 General Fund	02/01/2026	Hillsborough County BOCC	7985020000-031726	630 Mirabay Blvd 02/26	21.00
815 General Fund	02/01/2026	Hillsborough County BOCC	1985020000-031726	829 A Islebay Dr 02/26	322.17
815 General Fund	02/01/2026	Hillsborough County BOCC	4985020000-031726	5702 Tortoise Pl 02/26	32.15
815 General Fund	02/01/2026	Hillsborough County	0506800000-031726	115 Mirabay Blvd	492.73

**Harbor Bay Community Development District
Summary A/P Ledger
From 02/01/2026 to 02/28/2026**

Fund Name	GL posting date	Vendor name	Document number	Description	Balance Due
815 General Fund	02/01/2026	BOCC Hillsborough County	6985020000-031726	02/26 5704 Sea Turtle PI	97.86
815 General Fund	02/01/2026	BOCC Hillsborough County	5985020000-031726	02/26 5737 Tortoise PI 02/26	143.33
815 General Fund	02/01/2026	J Courts, Inc.	2461	Tennis Court Nets 02/26	800.00
815 General Fund	02/01/2026	J Courts, Inc.	2460	Maintenance 02/26	850.96
815 General Fund	02/01/2026	J Courts, Inc.	2456	Tennis Court Services 02/26	1,662.50
815 General Fund	02/01/2026	L. K. Industrial Services, Inc.	7795	OSHA Inspection 02/26	1,580.00
815 General Fund	02/01/2026	Lee Te Kim Lawn Care & Nursery	FEB 06859	Monthly Maintenance 02/26	41,166.66
815 General Fund	02/01/2026	Lee Te Kim Lawn Care & Nursery	FEB 06862	Irrigation Maintenance 02/26	5,166.67
815 General Fund	02/01/2026	Lee Te Kim Lawn Care & Nursery	FEB 06863	Maintenance - Park Square 02/26	15,000.00
815 General Fund	02/01/2026	Lee Te Kim Lawn Care & Nursery	FEB 06860	Water Use Permit 02/26	500.00
815 General Fund	02/01/2026	Lee Te Kim Lawn Care & Nursery	FEB 06861	Turfgrass Maintenance 02/26	23,601.67
815 General Fund	02/01/2026	National General Insurance Company	0000442350-010326	5248 Admiral Point Dr - 0000442350 01/26	2,432.00
815 General Fund	02/01/2026	Peak Engineering & Consulting, LLC	1370	Engineering Services 10/25	4,262.50
815 General Fund	02/01/2026	Peak Engineering & Consulting, LLC	1430	Engineering Services - Final Payment 12/25	6,125.00
815 General Fund	02/01/2026	Persson, Cohen & Mooney, P.A.	6793	Legal Services 02/26	19,005.00
815 General Fund	02/01/2026	Phenomenal Exercise Equipment Repair Services, Inc.	247027	Maintenance 02/26	145.00
815 General Fund	02/01/2026	Stearns Weaver Miller Weissler Alhadeff & Sitterson, P.A.	16124575	Professional Services 02/26	2,280.00
815 General Fund	02/01/2026	Stearns Weaver Miller Weissler Alhadeff & Sitterson, P.A.	16122895	Professional Services 01/26	602.50
815 General Fund	02/01/2026	TECO	221006323390-02272	Utility Services 02/26	140.17
815 General Fund	02/01/2026	TECO	221008458756-02272	Street Lights 02/26	11,529.74
815 General Fund	02/01/2026	TECO	211009425268-02272	Utility Services 02/26	352.23
815 General Fund	02/01/2026	TECO	211009424139-02272	Admiral Pointe - Utility Service 02/26	84.18
815 General Fund	02/01/2026	TECO	211009425011-02272	Utility Services 02/26	52.50
815 General Fund	02/01/2026	TECO	211009424568-02272	Admiral Pointe - Utility Service 02/26	1,140.03
815 General Fund	02/01/2026	TECO	311000030115-03062	Utility Services 02/26	371.90
815 General Fund	02/01/2026	TECO	311000030115-03062	Utility Services 02/26	2,214.39
815 General Fund	02/01/2026	TECO	311000030115-03062	Utility Services 02/26	307.26
815 General Fund	02/01/2026	TECO	311000030115-03062	Utility Services 02/26	13,333.48
815 General Fund	02/01/2026	Terminix	469439358	Pest Control 02/26	781.49
815 General Fund	02/01/2026	Triangle Pool Service	925170	Chlorine & Sulfuric Acid 02/26	536.85
815 General Fund	02/01/2026	USA Services of Florida, LLC	FL12284696	Sweeping - Mira Bay 02/26	1,078.66
815 General Fund	02/01/2026	Wells Fargo Vendor Financial Services, LLC	5037869508	Contract 450-0078530-000 03/26	53.92
Sum for 815, 192					172,782.37
815, 193					

**Harbor Bay Community Development District
Summary A/P Ledger
From 02/01/2026 to 02/28/2026**

Fund Name	GL posting date	Vendor name	Document number	Description	Balance Due
815 Reserve Fund	02/01/2026	J Courts, Inc.	2462	Tennis Court Resurfacing - Balance 02/26	18,450.00
Sum for 815, 193					18,450.00
Sum for 815					197,202.11
Sum Total					197,202.11

Harbor Bay Community Development District
Notes to Unaudited Financial Statements
February 28, 2026

Balance Sheet

1. Trust statement activity has been recorded through 02/28/26.
2. See EMMA (Electronic Municipal Market Access) at <https://emma.msrb.org> for Municipal Disclosures and Market Data.
3. For presentation purposes, the Reserves are shown in a separate fund titled Reserve Fund.

Summary A/R Ledger – Payment Terms

4. Payment terms for landowner assessments are (a) defined in the FY25-26 Assessment Resolution adopted by the Board of Supervisors, (b) pursuant to Florida Statutes, Chapter 197 for assessments levied via the county tax roll.

Summary A/R Ledger – Subsequent Collections

5. General Fund – Payment for Invoice AR00003098 in the amount of \$70,131.27 was received in March 2026.
6. Debt Service Fund 200 – Payment for Invoice AR00003098 in the amount of \$27,770.22 was received in March 2026.